



NO. S1901E02  
October 30, 2000

# SERVICE MANUAL

---

*Vision Master™ Pro 454*      **HM903DT**  
*Vision Master™ Pro 451*      **A902MT-v**

Copyright    Iiyama Corporation  
710-1 Kitaowaribe, Nagano-shi 381-0014 JAPAN

[ Revision Record ]

Rev.	Section	Contents

# CONTENTS

	Page
SAFETY PRECAUTION.....	i-ii
1. SET-UP ADJUSTMENTS.....	1-15
2. TIMING CHART.....	16
3. IC APPLICATION.....	17-18
4. CIRCUIT DESCRIPTION.....	19-30
5. SERVICE PARTS LIST.....	31-56
6. EXPLODED VIEW.....	57-65
7. DIAGRAMS.....	66-68

## NOTICE

The information in this document is subject to change without notice.

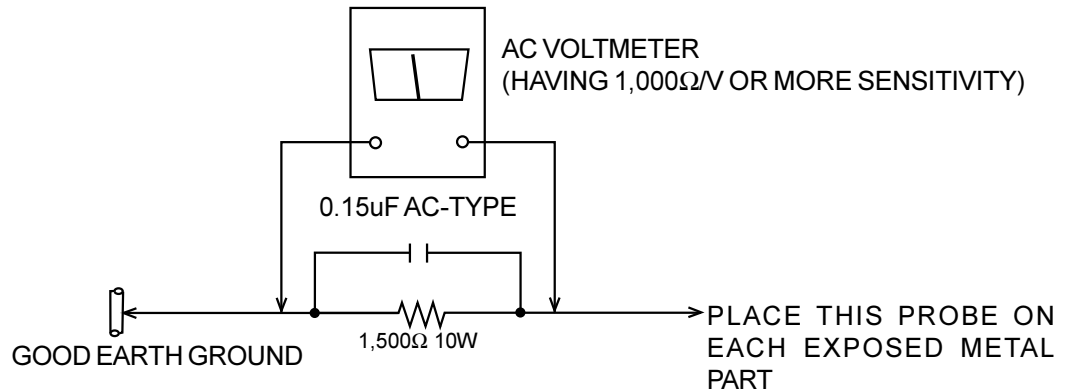
# SAFETY PRECAUTION

1. The design of this product contains special hardware, many circuits and components specially for safety purposes. For continued protection, no changes should be made to the original design unless authorized in writing by the manufacturer. Replacement parts must be identical to those used in the original circuits. Service should be performed by qualified personnel only.
2. Alterations of the design or circuitry of the products should not be made. Any design alterations or additions will void the manufacturer's warranty and will further relieve the manufacturer of responsibility for personal injury or property damage resulting therefrom.
3. Many electrical and mechanical parts in the products have special safety-related characteristics. These characteristics are often not evident from visual inspection nor can the protection afforded by them necessarily be obtained by using replacement components rated for higher voltage, wattage, etc. Replacement parts which have these special safety characteristics are identified in the parts list of Service manual. Electrical components having such features are identified by mark “#” on the schematics and “!” on the parts list in Service manual. The use of a substitute replacement which does not have the same safety characteristics as the recommended replacement part shown in the parts list of Service manual may create shock, fire, or other hazards.
4. Use isolation transformer.  
The chassis and any sub-chassis contained in some products are connected to the primary circuit of the AC power line. An isolation transformer of adequate capacity should be inserted between the product and the AC power supply point while performing any service on some products when the primary circuit of the AC power supply is exposed.
5. The high voltage applied to the picture tube must conform with that specified in Service manual. Excessive high voltage conditions should be kept to a minimum, or should be prevented. If severe arcing occurs, remove the AC power immediately and determine the cause by visual inspection (incorrect installation, cracked or melted high voltage harness, poor soldering, etc.) To maintain the proper minimum level of soft X-ray emission, components in the high voltage circuitry including the picture tube must be the exact replacements or alternatives approved by the manufacturer of the complete product.
6. **Isolation Check**  
(Safety for Electrical Shock Hazard)  
After reassembling the product always perform an isolation check on the exposed metal parts of the cabinet (video input and output terminals, control knobs, screwheads, control shafts, etc.) to be sure the product is safe to operate without danger of electrical shock.
  - (1) **Dielectric Strength Test**  
The isolation between the AC primary circuit and all metal parts exposed to the user, particularly any exposed metal part having a return path to the chassis should withstand a voltage of 1,500V AC(r.m.s.), 20mA(current sensitivity) for a period of one minute.  
This method of test requires a test equipment not generally found in the service trade.
  - (2) **Leakage Current Check**  
Plug the AC line cord directly into the AC outlet (do not use a line isolation transformer during this check.). Using a “Leakage Current Tester”, measure the leakage current from each exposed metal part of the cabinet, particularly any exposed metal part having a return path to the chassis, to a known good earth ground (water pipe etc.). Any leakage current must not exceed 3.5mAAC(r.m.s.).

### Alternate Check Method

Plug the AC line cord directly into the AC outlet (do not use a line isolation transformer during this check.). Use an AC voltmeter having 1,000 ohms per volt or more sensitivity in the following manner. Connect a 1,500 $\Omega$  10W resistor paralleled by a 0.15 $\mu$ F AC-type capacitor between an exposed metal part and a known good earth ground (water pipe etc.).

Measure the AC voltage across the resistor with the AC voltmeter. Move the resistor connection to each exposed metal part, particularly any exposed metal part having a return path to the chassis, and measure the AC voltage across the resistor. Now, reverse the plug in the AC outlet and repeat each measurement. Any voltage measured must not exceed 2.45V AC(r.m.s.). This corresponds to 3.5mA AC(r.m.s.).



# 1. SET-UP ADJUSTMENTS

The following adjustments should be made when a complete realignment is required or a new picture tube is installed.

## <Required measuring equipment>

- Signal generator (Programmable video generator)..... Leader 1604A
- DC voltmeter (300V DC range)
- Note:** Digital multimeter can also be used.
- High voltage probe (0-30kV DC)
- Color analyzer..... Minolta CA-100
- Photometer..... Minolta LS-100
- Electric field meter..... Combinova EFM 100
- Scale (Two 50cm scales put together so that no visual aberration occurs.)
- Frequency counter
- Digital wattage meter
- Landing meter..... LSS LND-070 or 072
- Degausser
- Headphones
- CD player
- Audio-LR confirmation equipment
- USB compliant computer
- Interface adapter (Iiyama handmade)
- Short-connector (Iiyama handmade)

## <Preparation>

1. Place the monitor without tilting.
2. Connect the signal cable from the signal generator to the monitor.
3. Face the CRT screen to east so as not to be influenced by magnetic force.
4. Turn ON the Power Switch, and degauss the entire screen with degausser. → See "EXTERNAL DEGAUSS".
5. Perform adjustment by setting the brightness to center and the contrast to maximum, except where specifically indicated.
6. Receive MODE 5 and turn ON the Power Switch. Perform adjustment after a warm-up of at least an hour.
7. Adjustment data is automatically saved in the memory when the on screen display disappears, when another signal is received.

**Note:** This monitor should be checked and adjusted by connecting it to a signal generator, then entering and running the timing charts both below and of Chapter 2.

fH (kHz)	Resolution*	Sync polarity			Sync on green	Horizontal (µsec)					Vertical (msec)				
		H	V	Comp		A	B	C	D	E	O	P	Q	R	S
29.2	640×400	P	P	–	–	34.26	2.74	3.43	27.40	0.69	14.285	0.103	0.444	13.704	0.034
30.9	800×600	P	P	–	–	32.36	2.57	3.34	25.68	0.77	20.000	0.097	0.455	19.416	0.032
77.8	320×350	P	P	–	–	12.69	1.06	1.64	9.40	0.59	5.000	0.038	0.508	4.442	0.012
133.9	1600×1200	P	P	–	–	7.47	0.60	1.03	5.41	0.43	9.524	0.022	0.530	8.964	0.008

\* The resolutions are only for your reference when using Leader 1604A.

# ADJUSTMENT MODE

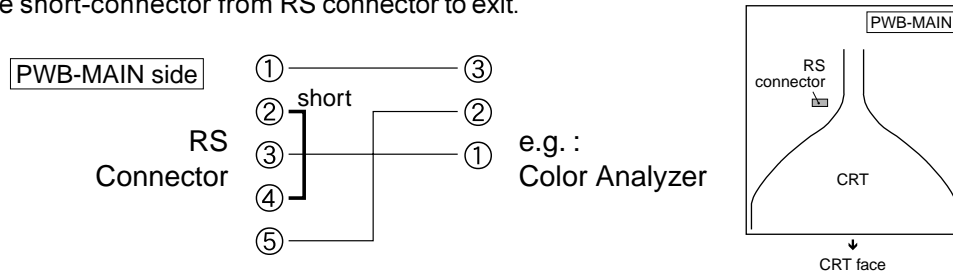
There are two different modes available to adjust the monitor as described below. The adjustment with '□' in front of the title are only available under User Mode. The adjustments with '■' in front of the title are only available under Factory Mode. You can perform the other adjustments by either User or Factory Mode. Please change the mode as required.

## USER MODE:

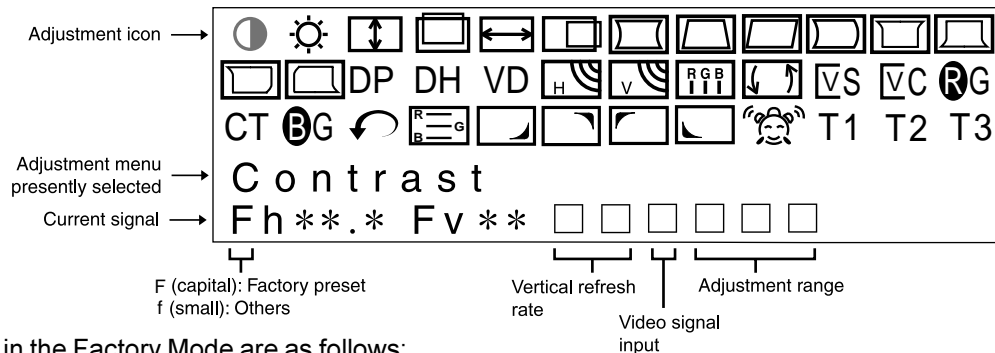
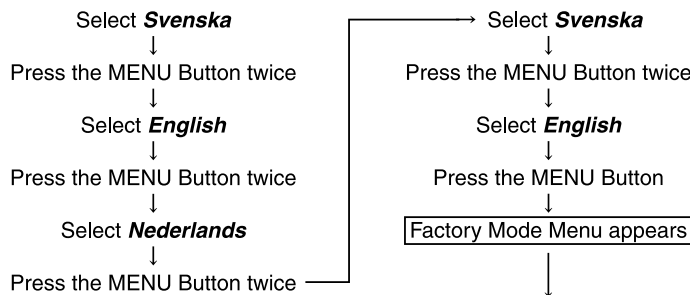
Turn ON the Power Switch and you are in the User Mode.

**FACTORY MODE:** There are two ways to enter the Factory Mode.

1. Turn OFF the Power Switch. Short between pins 2 and 4 of RS connector on the PWB-MAIN with a short-connector. Turn ON the Power Switch and you are in the Factory Mode. The following Factory Mode Menu appears on the screen when you press the MENU Button. Turn OFF the Power Switch and remove the short-connector from RS connector to exit.



2. In the adjustment menu, select "Function" on the Main Menu and then select "Language" on the Sub-Menu. Follow the flow chart below and you are in the Factory Mode. Turn OFF the Power Switch to exit.



The menu items in the Factory Mode are as follows:

Contrast	Pincushion	Pinbalance Top	V moire	Temp cont	Top-left
Brightness	Trapezoid	Pinbalance Btm	H convergence	Blue gain	Bottom-left
V-size	Parallelogram	DBF Para	Tilt-Dy	rrc	CRT check
V-position	Pinbalance	DBF Phase	V linear side	V-conver	DA TEST 1
H-size	Sidepin Top	V DBF	V linear corner	Bottom-right	DA TEST 2
H-position	Sidepin Bottom	H moire	Red gain	Top-right	DA TEST 3 *

\* DA TEST 3 helps you to perform H/V-BLANKING and H-CONVERGENCE / TILT-DY confirmations in this SET-UP ADJUSTMENTS. The following items are displayed automatically in turn.

1. H-convergence → 2. Tilt-dy → 3. H/V-blanking

## EXTERNAL DEGAUSS

Make sure you disable the Bottom-right, Top-right, Top-left, Bottom-left, and rrc settings before performing the external degauss. Follow the procedure below depending on the adjustment mode you are in.

### PROCEDURE

#### USER MODE

- 1) Select Degauss and press the MENU Button so that the Bottom-right, Top-right, Top-left and Bottom-left will be disabled.
- 2) Degauss the entire screen with degausser while the Degauss is activated (approx. 6 seconds).

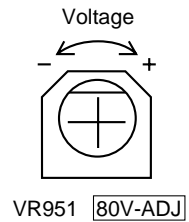
#### FACTORY MODE

- 1) Select CRT Check and press the MENU Button so that the Bottom-right, Top-right, Top-left, Bottom-left, and rrc will be disabled.
- 2) Confirm that the OSD stays displayed on the screen.  
**Note:** If the OSD disappears, restart from 1).
- 3) Degauss the entire screen with degausser.



### 1-1. 80V-ADJ adjustment [PWB-MAIN]

- 1) Receive a cross-hatch inverted signal of MODE 1 when applying the AC voltage of  $110\pm 10V$ .
- 2) Connect the DC voltmeter between CONNECTOR TP and GND (chassis).
- 3) Adjust the voltage to DC  $80\pm 0.5V$  with VR951 (80V-ADJ).

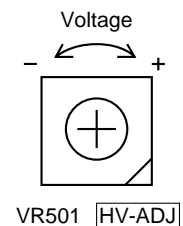


### 1-2. ANODE VOLTAGE adjustment [PWB-MAIN]

#### WARNING !

VR501 (HV-ADJ) has been carefully factory-adjusted for each unit in order to satisfy regulations regarding X-radiation. Further adjustment on VR501 shall not be performed. In case of adjustment, the adjusted position of VR501 must be fixed by a soldering iron to prevent it from rotating.

- 1) Receive a cross-hatch inverted signal of MODE 5.
- 2) Turn OFF the Power Switch.
- 3) Connect a high-voltage probe between CRT anode and GND (chassis).
- 4) Turn ON the Power Switch.
- 5) Adjust the high-voltage to  $26.0\pm 0.2kV$  with VR501 (HV-ADJ).
- 6) Confirm the variation of high-voltage is within  $\pm 0.2kV$  when receiving MODE 1 and MODE 6 respectively.
- 7) Turn OFF the Power Switch and remove the high-voltage probe.



### 1-3. POWER FACTOR CIRCUIT confirmation [PWB-MAIN]

- 1) Receive a cross-hatch inverted signal of MODE 5.
- 2) Turn OFF the Power Switch.
- 3) Connect the DC voltmeter between TP4 and TP0.
- 4) Turn ON the Power Switch.
- 5) Confirm that the voltage is DC  $400\pm 10V$ .
- 6) Remove the DC voltmeter.

#### ■1-4. TEMPERATURE SENSOR confirmation

- 1) Receive a cross-hatch inverted signal of MODE 5.
- 2) Select CRT Check and press the MENU Button.
- 3) Confirm that respective temperature of CRT fannel and monitor front displayed on the screen is as follows: actual temperature  $\pm 5^{\circ}\text{C}$ .

CRT Check

\* \* \* \*

35

} CRT  
fannel

30

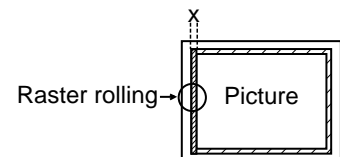
} Monitor  
front

#### ■1-5. FH-LIMITER confirmation

- 1) Receive a cross-hatch inverted signal of fH 29.2kHz.
- 2) Confirm that the picture disappears. Also, make sure the horizontal oscillation frequency is within the specified range: 58-62kHz.
- 3) Receive fH 30.9kHz and confirm that the picture is synchronized.
- 4) Receive fH 133.9kHz and confirm that the picture disappears. Also, make sure the horizontal oscillation frequency is within the specified range above.
- 5) Receive fH 77.8kHz and confirm that the picture is synchronized.
- 6) Turn OFF the power of signal generator and confirm that the picture disappears. Also make sure the horizontal oscillation frequency is within the specified range above.
- 7) Remove the frequency counter.

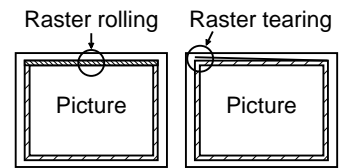
#### ■1-6. H-BLANKING confirmation

- 1) Receive a cross-hatch inverted signal of MODE 5.
- 2) Minimize the horizontal size (H-size) with the front buttons.
- 3) Select DA TEST 3 and press the MENU Button so that the automatic confirmation program starts.
- 4) Confirm that X of the right hand side figure is as follows:  $X \leq 3.0\text{mm}$ .
- 5) Adjust the horizontal size roughly with the front buttons.



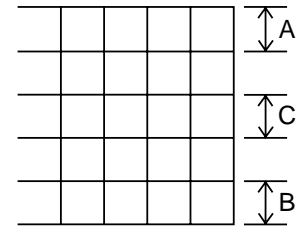
### ■1-7. V-BLANKING confirmation

- 1) Receive a cross-hatch inverted signal of MODE 5.
- 2) Adjust the vertical size and position (V-size and V-position) of the picture roughly with the front buttons.
- 3) Select DA TEST 3 and press the MENU Button so that the automatic confirmation program starts.
- 4) Confirm that the back-raster is not rolling or tearing at the top.
- 5) Confirm that no retrace line is over the picture.



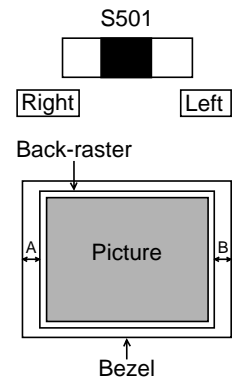
### ■1-8. V-LIN adjustment

- 1) Receive a cross-hatch inverted signal of MODE 5.
- 2) Adjust the vertical size so that the size is  $270 \pm 4$ mm.
- 3) Adjust the vertical linear corner (V linear corner), so that difference between A and B of the right hand side figure is as follows:  $|A-B| \leq 0.5$ mm
- 4) Adjust the vertical linear side (V linear side), so that A, B and C are almost equal.



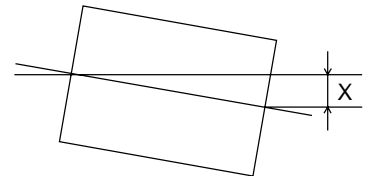
### ■1-9. H-CENT adjustment [PWB-MAIN]

- 1) Receive a cross-hatch inverted signal of MODE 5.
- 2) Adjust the horizontal size and position of the picture roughly with the front buttons.
- 3) Maximize the brightness so that the back-raster appears on the screen.
- 4) Set S501 to the right, center or left so that A and B in the right hand side figure are almost equal.
- 5) Return the brightness to center indication.



### ■1-10. TILT-DY adjustment

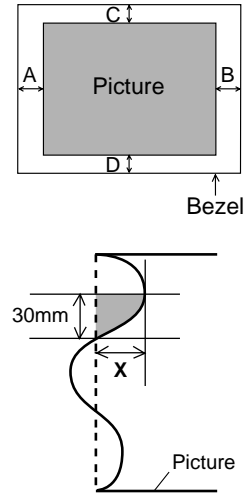
- 1) Receive a cross-hatch inverted signal of MODE 5.
- 2) Adjust the tilt deflection yoke (Tilt-Dy) with the ► / ◀ Buttons so that X of the right hand side figure is as follows:  $|X| \leq 0.5$ mm.



## ■1-11. PICTURE SIZE, POSITION AND DISTORTION adjustment (Criteria)

- 1) Receive a cross-hatch inverted signal of MODE 5.
- 2) Adjust the picture size and position to the specified setting below.  
 H-size:  $360 \pm 10 \text{mm}$       H-position:  $|A-B| < 8 \text{mm}$   
 V-size:  $270 \pm 10 \text{mm}$       V-position:  $|C-D| < 8 \text{mm}$
- 3) Correct the side distortion with the front buttons so that X of the right hand side figure is as follows:  $|X| \leq 0.5 \text{mm}/30 \text{mm}$  when selecting the most remarkable distortion with the naked eye.  

Pincushion	Parallelogram
Trapezoid	Sidepin Top / Bottom
Pinbalance	Pinbalance Top / Bottom



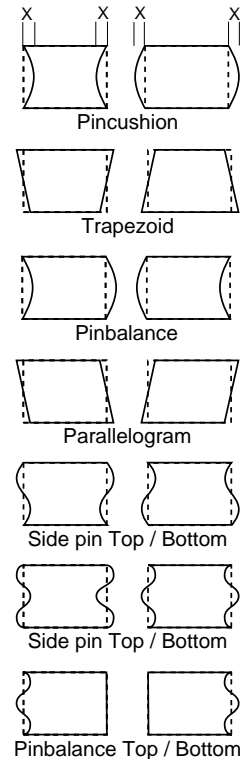
## ■1-12. PICTURE SIZE, POSITION AND DISTORTION adjustment

- 1) Receive a cross-hatch inverted signal of MODE 5.
- 2) Adjust the picture size, position and distortion roughly with the front buttons to the reference settings below.  
 H-size:  $360 \pm 10 \text{mm}$       H-position:  $|A-B| < 8 \text{mm}$   
 V-size:  $270 \pm 10 \text{mm}$       V-position:  $|C-D| < 8 \text{mm}$   
 $|X| \leq 1.0 \text{mm}/30 \text{mm}$  when selecting the most remarkable distortion with the naked eye.

**Note:** The picture should be within the bezel.

- 3) Receive a cross-hatch inverted signal of all preset modes respectively.
- 4) Adjust the picture size and position to the specified setting below.  
 H-size:  $360 \pm 10 \text{mm}$       H-position:  $|A-B| < 8 \text{mm}$   
 V-size:  $270 \pm 10 \text{mm}$       V-position:  $|C-D| < 8 \text{mm}$
- 5) Correct the Pincushion and Trapezoid distortion with the front buttons so that X of the right hand side figure is as follows:  $|X| \leq 0.5 \text{mm}/30 \text{mm}$  when selecting the most remarkable distortion with the naked eye.

**Note:** No other adjustment items for distortion than the above should be adjusted.



## □1-13. RESET confirmation


- 1) Receive a cross-hatch inverted signal of MODE 5.
- 2) Change the horizontal position (H-position) roughly with the front buttons.
- 3) Perform Reset.
- 4) Confirm that the adjustment data above is reset to the factory setting.

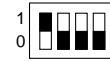
## ■1-14. Automatic COLOR adjustments

**WARNING:** Do not change the horizontal and vertical sync signal or the frequency while the automatic COLOR adjustments are underway.

### Color analyzer setting:

- Luminance unit switch: cd/m<sup>2</sup>
- B.P.S. DIP switch: 9600 (1000)
- Turn ON the color analyzer switch and press 0-CAL switch before use.

cd/m<sup>2</sup>  fL  
Luminance unit switch



B. P. S. DIP switch

- 1) Be sure to enter the Factory Mode by using the short-connector.
- 2) Connect the interface adapter from RS-232C of the color analyzer to the PWB-RS of the short-connector.
- 3) Select VIDEO IN 2 for the signal input and receive a white window signal of MODE 5.
- 4) Turn OFF the R, G and B outputs on the signal generator.
- 5) Apply a color analyzer probe to the center of the screen.
- 6) Turn ON the Remote Switch of the color analyzer so that the automatic CUT-OFF adjustment starts.
- 7) Turn ON the R, G and B outputs on the signal generator so that the COLOR TEMPERATURE and CONTRAST LIMIT adjustments start automatically.

<COLOR TEMPERATURE>

The X and Y specified readings of the color analyzer are as follows:

CT 1 (9300K)

X: 0.283±0.008

Y: 0.297±0.008

<CONTRAST>

The specified contrast range is 120±6cd/m<sup>2</sup>.

**Note:** In case that the contrast is not within the specified range above, repeat 4) to 7).

- 8) The OSD disappears.
- 9) Press the MENU Button so that the OSD appears.
- 10) All adjustment data is stored when the OSD disappears.
- 11) Turn OFF the Remote Switch of the color analyzer.

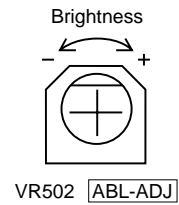
**Note:** The adjustments above can be repeated by turning OFF and ON the Power Switch.

## ■1-15. GRAY SCALE confirmation

- 1) Receive a 16-gradation gray scale signal of MODE 5.
- 2) Make sure the 15th gradation on the gray scale is barely visible when the 16th gradation (back raster) is not visible at all.

### ■ 1-16. BRIGHTNESS adjustment [PWB-MAIN]

- 1) Receive an entire white raster signal of MODE 5.
- 2) Apply a photometer to the screen center.
- 3) Adjust VR502 (ABL-ADJ) so that photometer reads  $105 \pm 5 \text{cd/m}^2$ .



### ■ 1-17. SYNC SIGNAL INPUT confirmation

- 1) Receive a cross-hatch inverted signal of MODE 4.
- 2) Select composite and sync on green signal inputs respectively by the signal generator.
- 3) Confirm that the picture is displayed normally.

### □ 1-18. SIGNAL SELECT confirmation

- 1) Receive a cross-hatch inverted signal of MODE 5.
- 2) Switch the signal input to VIDEO IN 1 and VIDEO IN 2 respectively.
- 3) Press the Input Select Button (VIDEO 1/2) for approx. 5-6 seconds.
- 4) Confirm that the picture is displayed normally.

### □ 1-19. POWER MANAGEMENT confirmation

- 1) Turn OFF the Power Switch and connect a digital wattage meter.
- 2) Turn ON the Power Switch.
- 3) Receive a cross-hatch inverted signal of MODE 5.
- 4) Turn OFF the R, G and B outputs on the signal generator.
- 5) Disconnect the H/HV and V cables.
- 6) Confirm that the input wattage is 3W or less and the Power Indicator turns to orange.
- 7) Connect the H/HV and V cables and confirm that the picture appears.
- 8) Turn OFF the Power Switch and remove the digital wattage meter.
- 9) Turn ON the Power Switch.

### ■ 1-20. H-CONVERGENCE confirmation

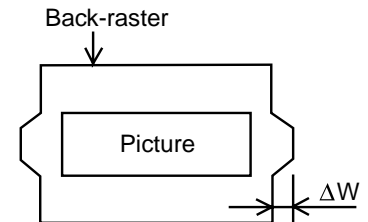
- 1) Receive a cross-hatch inverted signal of MODE 5.
- 2) Select H-convergence or DA TEST 2, and press the MENU Button so that the automatic confirmation program starts.
- 3) Confirm that the horizontal line is diverged.

## ■ 1-21. V-CONVERGENCE confirmation

- 1) Receive a cross-hatch inverted signal of MODE 5.
- 2) Select V-convergence or DA TEST 2, and press the MENU Button so that the automatic confirmation program starts.
- 3) Confirm that the vertical line is diverged.

## ■ 1-22. RASTER REGULATION (DYNAMIC) confirmation

- 1) Receive an entire white signal of MODE 5.
- 2) Set the input signal by the signal generator as follows:  
V-DISP-TIME: 150 V-POSI-TIME: 450
- 3) Maximize the brightness or set the signal level to 0.9Vp-p by the signal generator.
- 4) Confirm that  $\Delta W$  of the right hand side figure is 1.0mm or less when turning the luminance volume on the signal generator to the maximum and "1" respectively.
- 5) Return the brightness to center indication.



## ■ 1-23. FOCUS [PWB-MAIN]

- 1) Receive a green cross-hatch signal of MODE 5.
- 2) Adjust FOCUS-A VR of T501 (FBT) to make the vertical lines sharpest at points L, M and R as shown in Fig 1.
- 3) Adjust FOCUS-B VR of the T501 to make the horizontal center line sharpest at points L, M and R as shown in Fig. 1.
- 4) If the focus at points T and M is as shown in Fig. 2, adjust V-DBF in the menu with the front buttons to make the horizontal lines have the same thickness at points T, M and B. And adjust the FOCUS-B VR again to make the horizontal lines sharpest at points T, M and B. (V-DBF should not be adjusted when focus at points T and M is optimum.)
- 5) If the focus at points L and M is as shown in Fig. 3 or vice versa, adjust DBF Para and DBF Phase in the menu with the front buttons to make the horizontal center line have the same thickness at points L, M and R. And adjust the FOCUS-B VR again to make the horizontal center line sharpest at points L, M and R. (DBF Para and DBF Phase should not be adjusted when focus at points L and M is optimum.)
- 6) Repeat 2) to 5) until the focus is optimum.
- 7) Confirm no focus variation on the entire screen.
- 8) Check the focus with red and blue respectively.
- 9) Receive a H-character signal and repeat 7).
- 10) Repeat the FOCUS adjustments until the focus with red, green and blue is optimum.

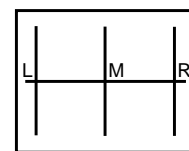
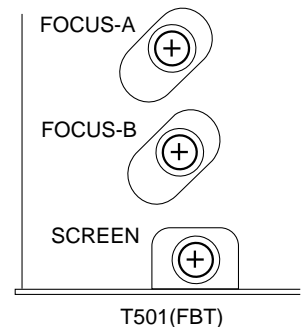


Fig.1

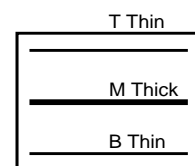


Fig.2

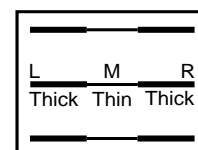
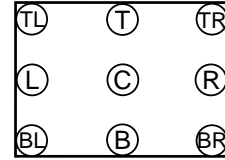


Fig.3

## 1-24. LUMINANCE DIFFERENCE confirmation

- 1) Receive an entire white signal of MODE 5.
- 2) Apply a photometer to the two points where the luminance difference is remarkable with the naked eye.
- 3) Confirm that the luminance difference is 22.5cd/m<sup>2</sup> or less.



## 1-25. AUDIO confirmation

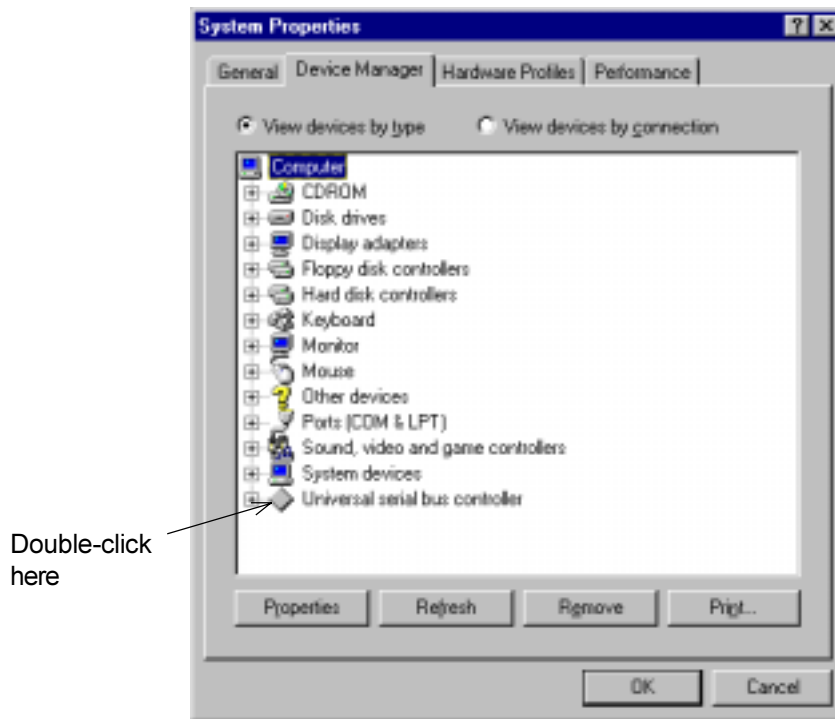
- 1) Turn the Volume Control from 0% to 100% and make sure the sound is normal without hum etc.
- 2) Set the Volume Control at mechanical center.
- 3) Connect the output of a CD player to the Audio Connector and make sure the right and left speaker works normally.
- 4) Turn the Volume Control and make sure the volume varies.
- 5) Connect Audio-LR confirmation equipment between the Audio Connector and CD player.
- 6) Turn off left switch of the Audio-LR confirmation equipment and make sure the right speaker works normally.
- 7) Turn off right switch of the Audio-LR confirmation equipment and make sure the left speaker works normally.
- 8) Turn the Volume Control to 0% and connect headphones to the Headphone Connector.
- 9) Confirm that the Headphones don't make noise.
- 10) Turn the Volume Control from 0% to 100% and make sure the sound from the both headphones is well balanced and normal without hum etc.

## 1-26. USB Operation Check

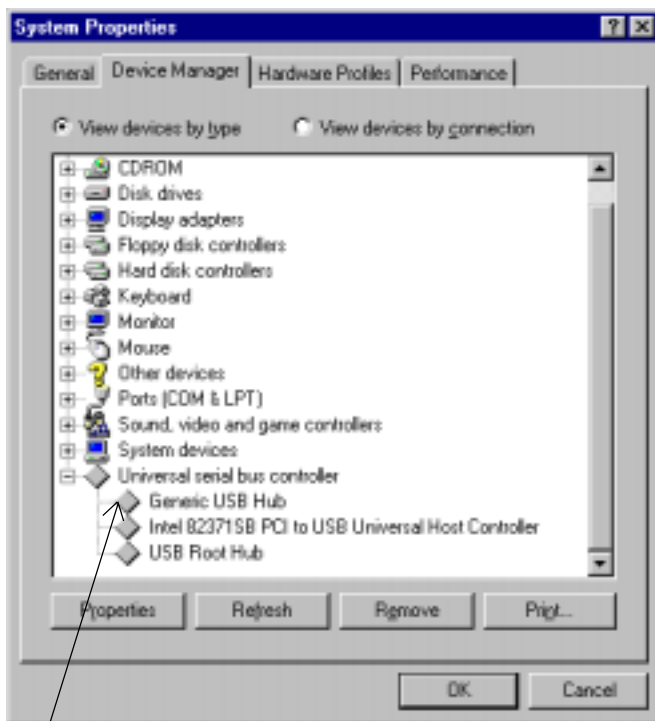
- 1) Connect cables according to the user manual.
- 2) Turn ON the Power Switch of the monitor and computer.
- 3) Double-click "Universal serial bus controller" as shown in Fig 1 on next page.
- 4) Confirm that "Generic USB Hub" or "Iiyama USB Hub" appears as shown in Fig 2.
- 5) Disconnect the USB Cable from the USB compliant computer.
- 6) Double-click "Universal serial bus controller".
- 7) Confirm that "Generic USB Hub" or "Iiyama USB Hub" disappears as shown in Fig 3.
- 8) Connect the USB Cable to the stand.
- 9) Repeat 1) to 5) and confirm that the USB function works normally.



**Fig. 1**

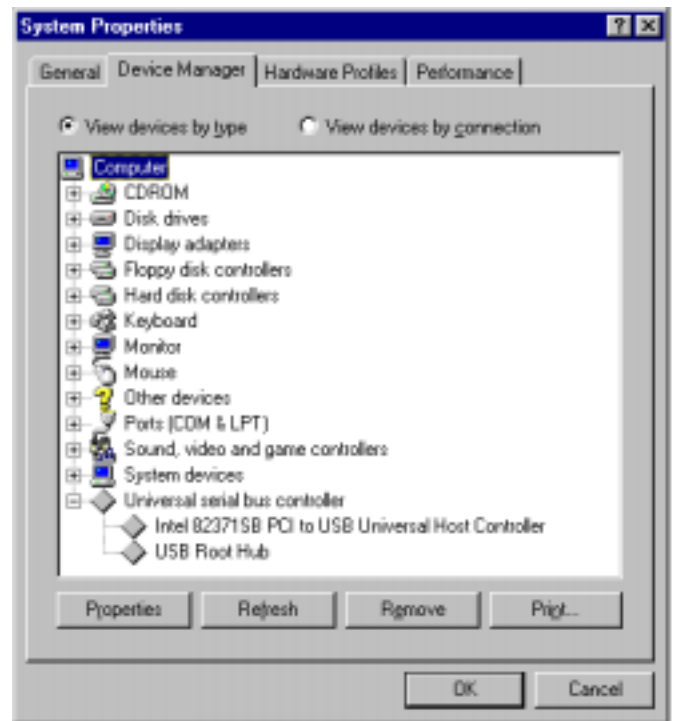


**Fig. 2**



“Generic USB Hub” or “Iiyama USB Hub”

**Fig. 3**



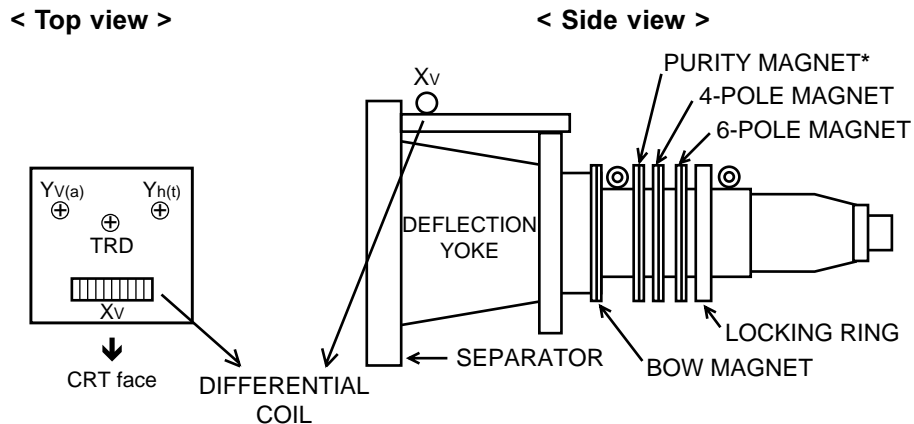
## ■ 1-27. ITC (Integrated Tube Component) adjustments

The following ITC adjustments should be made only when a new picture tube is installed, or convergence is poor. All set-up adjustments above-mentioned must be completed before any further ITC adjustment is attempted. Receive an entire white raster signal and turn ON the Power Switch. Perform adjustment after a warm-up of at least an hour.

Perform the following adjustments by setting H-convergence and V-convergence to center indication.

**Notes:** See Chapter 5 concerning parts list for the ITC adjustments.

\* PURITY MAGNET should not be turned during the ITC adjustments.



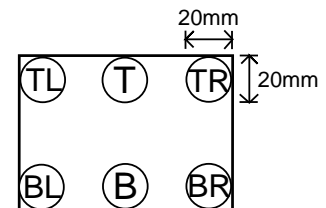
### 1-27-1. LANDING correction

#### Landing meter setting:

- Mode Select Switch: Monitor Normal
- **Note:** Mode Select Switch should be set before turning on the power switch of the landing meter.
- Volt: 2V
- Time: 50ms
- Gain: 7
- Unit: % for LND-070, 0.8 $\mu$ m (1%=0.8 $\mu$ m) for LND-072

- 1) Face the CRT screen to east and set it vertically.
- 2) Degauss the entire screen with degausser. → See "EXTERNAL DEGAUSS".
- 3) Select DEGAUSS and press the MENU Button.
- 4) Receive an entire green signal.
- 5) Adjust the horizontal size to make it full-scan.
- 6) Apply the landing meter to TL (top-left), TR (top-right), BL (bottom-left) and BR (bottom-right) in the right hand side figure.
- 7) Confirm that "H" reading of the landing meter is within  $\pm 20\%$  at each point.
- 8) Adjust rrc with the front buttons so that the "H" reading difference between T (top) and B (bottom) in the right hand side figure is as follows:  $|T-B| = \pm 3\%$ .
- 9) Adjust Bottom-right, Top-right, Top-left and Bottom-left respectively with the front buttons so that "H" reading of the landing meter at each point is as follows:

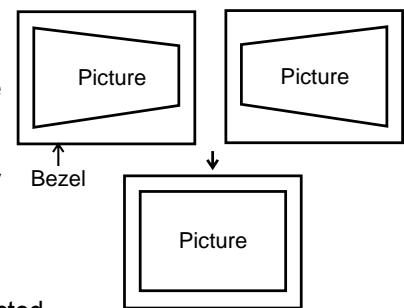
TL: -8 to -2%      TR: +2 to +8%      BL/BR: -3 to +3%



## 1-27-2. TRD adjustment

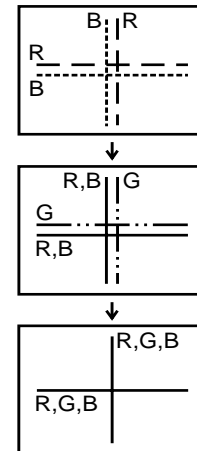
- Notes:**
1. This adjustment should be performed only when the picture distortion in the right hand side figure is permitted.
  2. Be sure to perform the 1-27-6. YV (a) adjustment after this adjustment because the convergence adjusted by YV volume is changed at the same time during this adjustment.

- 1) Receive a cross-hatch inverted signal.
- 2) Adjust the specified TRD volume so that the picture distortion is corrected.



## 1-27-3. STATIC CONVERGENCE adjustment

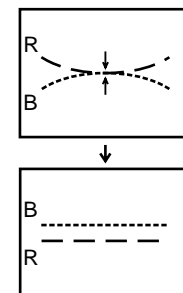
- 1) Receive a red and blue cross-hatch signal.
- 2) Adjust the 4-POLE MAGNET so that red and blue beams converge on the center cross lines.
- 3) Add green to the red and blue cross-hatch signal.
- 4) Adjust the 6-POLE MAGNET so that red and blue beams converge with green beam on the center cross lines.
- 5) Repeat the adjustment until red, blue and green beams converge each other.
- 6) Fix the 4-POLE MAGNET and the 6-POLE MAGNET by turning the LOCKING RING.
- 7) Mark the 4-POLE MAGNET and the 6-POLE MAGNET with paint marker (090Z029A01) so that adjusted position is understandable.



## 1-27-4. BOW MAGNET adjustment

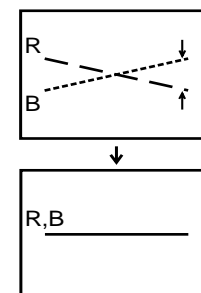
- 1) Receive a red and blue cross-hatch signal.
- 2) Adjust the BOW MAGNET so as to straighten an arched horizontal line.
 

**Note:** Must be careful not to misconverge vertical lines by this adjustment.
- 3) Perform the 1-29-3. STATIC CONVERGENCE adjustment so as to converge the red and blue lines.
- 4) Fix the BOW MAGNET with paint (090Z020A01).



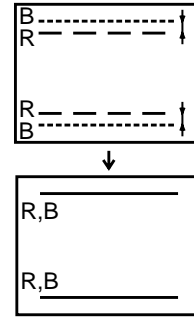
## 1-27-5. DIFFERENTIAL COIL adjustment (XV adjustment)

- 1) Receive a red and blue cross-hatch signal.
- 2) Adjust the DIFFERENTIAL COIL so that the horizontal cross line converge each other.



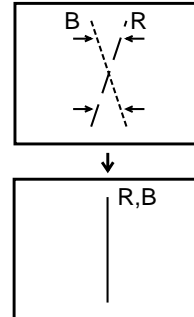
### 1-27-6. YV (a) adjustment

- 1) Receive a red and blue cross-hatch signal.
- 2) Adjust the specified YV (a) volume so that red and blue beams converge each other at the upper and lower edges of the horizontal line.



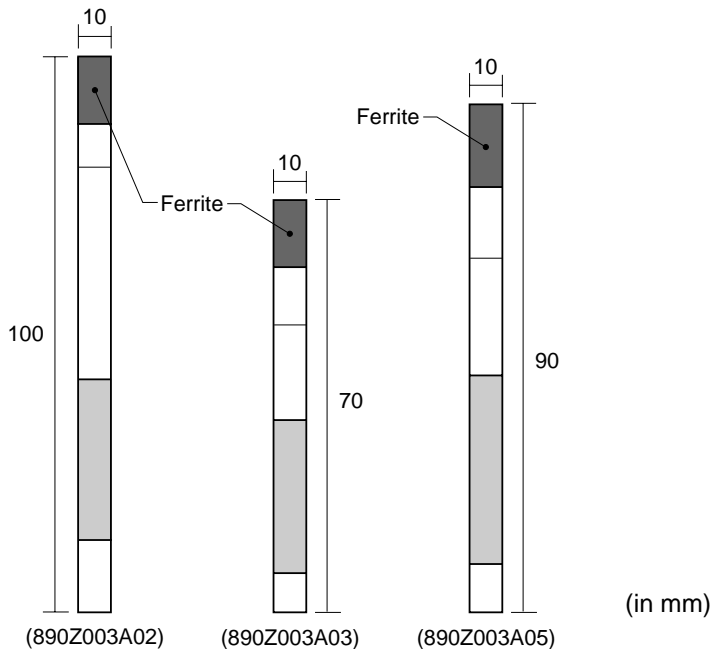
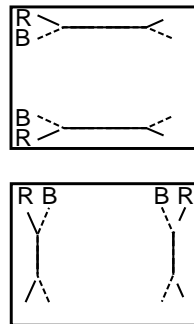
### 1-27-7. YH (t) adjustment

- 1) Receive a red and blue cross-hatch signal.
- 2) Adjust the specified YH (t) volumes so that vertical cross lines converge each.



### 1-27-8. SCREEN-CORNER MISCONVERGENCE correction

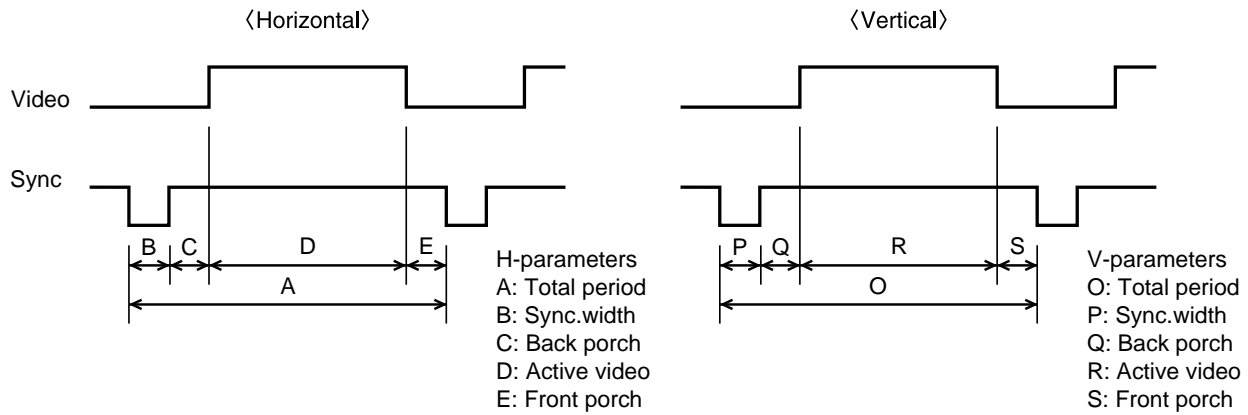
- 1) Receive a red and blue cross-hatch signal.
- 2) Affix a \*ferrite sheet (890Z003A02/890Z003A03/800Z003A05) between SEPARATOR and CRT corresponding to the partially misconverged areas.  
**Note:** Must be careful not to affect distortion by this correction.
- 3) Fix the ferrite sheet with ACETATE-TAPE (890P306A10).  
**Note:** Only for 800Z003A02 and 800Z003A03)



\*Ferrite sheet

(in mm)

## 2. TIMING CHART



- 16 -

Mode	VESA Timing Name	fH (kHz)	fV (Hz)	Sync polarity			Sync on green	Horizontal (μsec)					Vertical (msec)				
				H	V	Comp		A	B	C	D	E	O	P	Q	R	S
1	640×480 @60Hz	31.469	59.940	N	N	-	-	31.778	3.813	1.907	25.422	0.636	16.683	0.064	1.048	15.253	0.318
2	640×480 @85Hz	43.269	85.008	N	N	-	-	23.111	1.556	2.222	17.778	1.556	11.764	0.069	0.578	11.093	0.023
3	800×600 @85Hz	53.674	85.061	P	P	-	-	18.631	1.138	2.702	14.222	0.569	11.756	0.056	0.503	11.179	0.019
4	1024×768 @85Hz	68.677	84.997	P	P	-	-	14.561	1.016	2.201	10.836	0.508	11.765	0.044	0.524	11.183	0.015
5	1280×1024 @85Hz	91.146	85.024	P	P	-	-	10.971	1.016	1.422	8.127	0.406	11.761	0.033	0.483	11.235	0.011
6	1600×1200 @85Hz	106.250	85.000	P	P	-	-	9.412	0.837	1.325	6.972	0.279	11.765	0.028	0.433	11.294	0.009
7	1920×1440 @85Hz	128.520	85.000	P	P	-	-	7.781	0.633	1.078	5.625	0.445	11.765	0.023	0.529	11.204	0.007

### 3. IC APPLICATION

Ref No.	Description	Application	Location (PWB)
<b>Deflection circuit</b>			
IC350	UPC1888FCT	H&V oscillator, Distortion / Size / Phase / DBF control	MAIN
IC401	LA7840L	Vertical deflection output	↑
IC502	SLA5057	S-correction switching	↑
<b>Power circuit</b>			
IC901	STR-G6551	Sub power control	STAND
IC920	LM317T	6.3V regulator (Heater voltage ON/OFF control)	↑
IC921	KIA431	5V output control	↑
IC950	KIA431	28V output control	MAIN
IC951	STR-F6676	Main power control	↑
IC952	MC34262/MC33262	Power factor control	↑
IC953	AN7712F/UPC2412HF	12V regulator	↑
IC350	UPC1888FCT	Variable B control	↑
IC351	7812	12V regulator	↑
IC208	7805	5V regulator	VIDEO
<b>Microprocessor circuit</b>			
IC104	TMP47P241VN	Sub microprocessor (741Z620-10)	STAND
IC301	TMP86PP11N	Microprocessor (741Z626-10)	MAIN
IC302	M51951BSL/KIA7045P	5V watcher	↑
IC303	24C08	E <sup>2</sup> PROM	↑
<b>High voltage circuit</b>			
IC501	MSPAD383	High voltage output control	MAIN
<b>Video &amp; Sync processing circuit</b>			
IC101	M61323SP	Video input switch	STAND
IC105	74LS157	H-sync and S.O.G. input switch	↑
IC102	24C21	E <sup>2</sup> PROM (DDC)	↑
IC103	24C21	E <sup>2</sup> PROM (DDC)	↑
IC201	CXA2153S	Video pre-amplifier	VIDEO
IC202	LM2412T	Video output	↑
IC203	M35047-057SP	On screen display control	↑
IC204	LM2480	Cut-off control	↑
<b>CRT circuit</b>			
IC205	M62334P	D/A converter	VIDEO
IC206	LA6510	POWER-0P-AMP (TILT, NS-RRC control)	↑
IC207	LA6510	POWER-0P-AMP (H/V-convergence control)	↑
IC801	LA6510/TA8410K	POWER-0P-AMP (BL/BR control)	MAIN
IC802	LA6510/TA8410K	POWER-0P-AMP (TL/TR control)	↑
<b>Additional function circuit</b>			
IC601	AN7522	AUDIO-AMP	STAND
IC701	ISP1122	USB control	↑
IC702	PCF8582C	E <sup>2</sup> PROM (USB)	↑

**Note:** Specifications of Microprocessor are on next page.

## Main microprocessor specifications

Pin	Name	Function	Pin	Name	Function
1	GND	GND	42	P36/VSYNC1	V-SYNC signal input
2	XIN	12MHz X'TAL	41	P35/HSYNC1	H-SYNC / COMP signal input
3	XOUT	12MHz X'TAL	40	P34/VSYNC0	V-SYNC signal out
4	TEST	GND	39	P33/HSYNC0	H-SYNC signal out
5	VDD	5V Vcc	38	P32/CLAMP0	Video clamper
6	P46	Cushion-S switching signal 1	37	P31/HOHALF	N.C.
7	P47	Cushion-S switching signal 2	36	P30/HIHALF	HM903DT and A902MT-v switch
8	RESET	Reset	35	P45/SDA3	Degauss control signal output
9	INT5/STOP/P20	Cushion-S switching signal 3	34	P44/SCL3	H-LIN-1 switching signal output
10	PWM0/P00	PWM-Landing BL	33	P43/SDA2	E <sup>2</sup> PROM SDA
11	PWM1/P01	PWM-Landing TL	32	P42/SCL2	E <sup>2</sup> PROM SCL
12	PWM2/P02	PWM-Landing BR	31	P41/SDA1	UPC1888/PRF/OSD/DA SDA
13	PWM3/P03	PWM-Landing TR	30	P40/SCL1	UPC1888/PRE/OSD/DA SCL
14	PWM4/P04	N.C.	29	P57/SO1	Sub microprocessor DATA-OUT
15	PWM5/P05	Cushion-S switching signal 4	28	P56/SI1	Sub microprocessor DATA-IN
16	PWM6/P06	Cushion-S switching signal 5	27	P55/SCK1	Sub microprocessor CLOCK
17	PWM7/P07	Cushion-S switching signal 6	26	P54/DVO	H-DRIVE switching signal output
18	AIN00/P10	A/D Magnetism X	25	P53/TI1/T01	H-LIN-2 switching signal output
19	AIN01/P11	A/D Magnetism X	24	P52/TI0/T00	Diagnostic mode
20	AIN02/P12	A/D funnel temperature	23	P51/INT1	Automatic adjustment data output
21	VREF	5V Vcc	22	P50/INT0	Automatic adjustment data input

## Sub microprocessor specifications

Pin	Name	Function	Pin	Name	Function
1	VREF	5V Vcc	28	VDD	5V Vcc
2	R40(AIN0)	Front Menu key signal (0/2.5V)	27	K03	GND
3	R41(AIN1)	Front four key signal (0/2/3/4V)	26	K02	GND
4	R42(AIN2)	Surrounding temperature detection	25	K01	GND
5	R43(AIN3)	N.C.	24	K00	GND
6	R71(WT0)	Volume control 1	23	HOLD	GND
7	R80(INT2)	N.C.	22	HOLD(KE0)	GND
8	R81(T2)	PS1 (main power off signal)	21	RESET	Reset
9	R82(INT1)	Signal select	20	XOUT	4MHz CLOCK
10	P10	Volume control 2	19	XIN	4MHz CLOCK
11	P11	Volume control 3	18	R92(SCK)	Main microprocessor CLOCK
12	P12	Volume control 4	17	R91(SO)	Main microprocessor DATA-IN
13	P13	LED signal out	16	R90(SI)	Main microprocessor DATA-OUT
14	Vss	GND	15	P20	PS2 (heater off)

# 4. CIRCUIT DESCRIPTION

## 4-1. POWER SUPPLY circuit

Power supply circuit consists of MAIN POWER circuit on PWB-MAIN and SUB POWER circuit on PWB-VIDEO. These circuits are an asynchronous switching power supply circuit of secondary output feedback with using IC901 and IC951 built-in output FET and control IC.

Power supply start procedure is as follows;

- ① Power switch is turned ON.
- ② SUB POWER circuit (5V and 8.5V output) is turned on.
- ③ K901 (RELAY) is turned on.
- ④ POWER FACTOR circuit (400V output) is turned on.
- ⑤ MAIN POWER circuit (80V, 28V, 15V and -12V output) is turned on.
- ⑥ Monitor is activated.

### (1) POWER FACTOR circuit

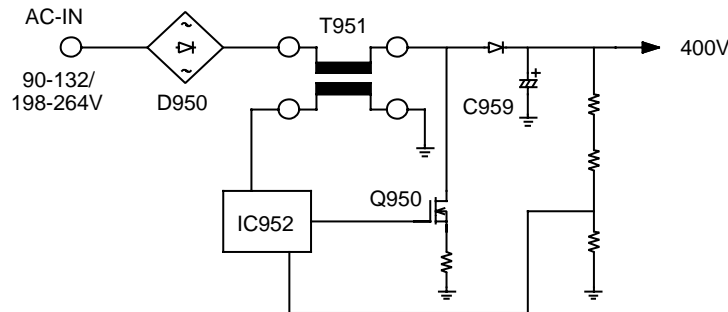
The voltage waveform from current is controlled to be in proportion with input voltage at pressor chopper circuit. This circuit is prevented from being harmonic by compared with following waveforms.

- ① The full-wave rectified voltage waveform from D950 via PWB-STAND and smoothed voltage waveform from C959.
- ② The voltage waveform from Q950 of source terminal.

① and ② waveforms are compared at IC952. Q950 is turned off when ② exceeds ①, and turned on when ② is 0V. This repetition is to change input current to substantially sinusoidal waveform and it corrects harmonic distortion.

The output voltage is set to 400V for world wide compliance.

The switching frequency is not constant as Q950 is turned on or off by monitoring input voltage and load current. The switching frequency is approx. 50-250kHz.





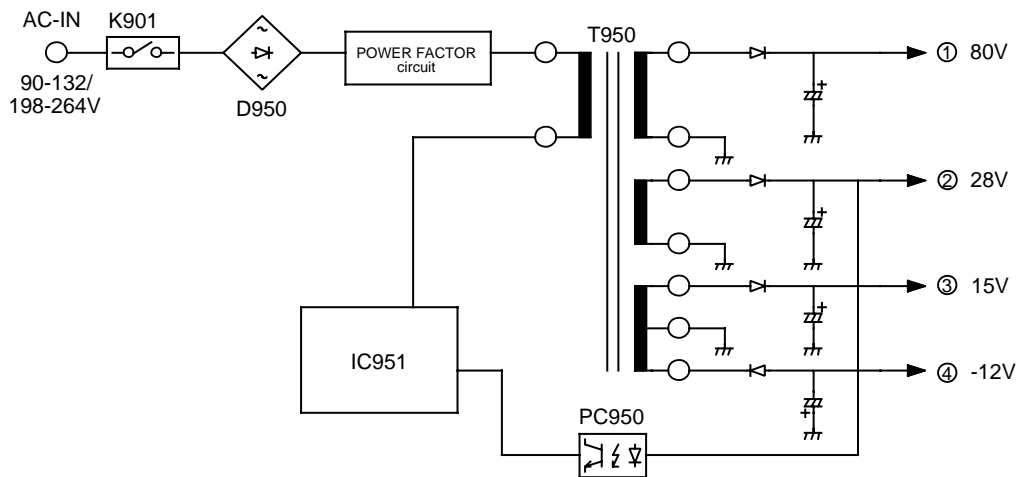
## (2) MAIN POWER circuit

400V is supplied to this circuit from the POWER FACTOR circuit. Start-up resistor R968 and R969 detect 4 pin of IC951 voltage (VCC-IN) and activate internal start circuit of IC951. When 4 pin of IC951 voltage turns to 16V, internal control circuit starts operation and auxiliary coil voltage between 8 and 9 pin of T950 (main transformer) is up to approx. 18V, and MAIN POWER circuit is activated.

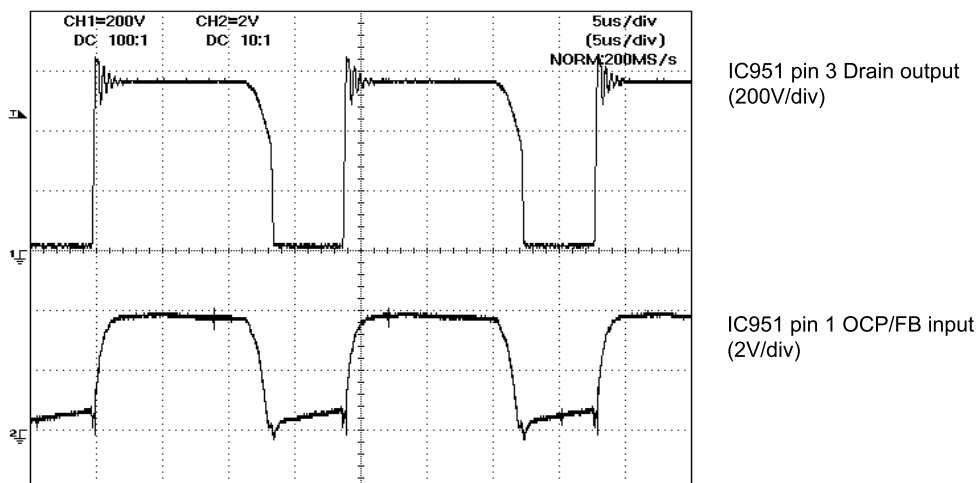
IC950 detects the load of 28V output voltage from the T950 secondary and controls the feedback current in PC950 (photocoupler) by fed back to 1 pin of IC951 (OCP/FB).

The T950 secondary provides the following DC voltages:

- ① 80V line: Supplied to the HIGH VOLTAGE OUTPUT (T501) and the VIDEO OUTPUT IC (IC202) and the CUT-OFF IC (IC204) as power source.
- ② 28V line: Supplied to the HORIZONTAL DEFLECTION OUTPUT (variable B voltage control) circuit and HORIZONTAL DRIVE circuit as power source.
- ③ 15V line: Supplied to the each 12V POWER CONTROL circuit, the CRT CORRECTION circuit and the VERTICAL OUTPUT IC (IC104, +) as power source.
- ④ -12V line: Supplied to the CRT CORRECTION circuit and the VERTICAL OUTPUT IC (IC104, -) as power source.



<Waveform> fH=91.2kHz fV=85Hz 1280 × 1024



- Note:**
1. The Switching frequency always vary because power supply is asynchronous.
  2. The actual waveform is not static like as above waveform.

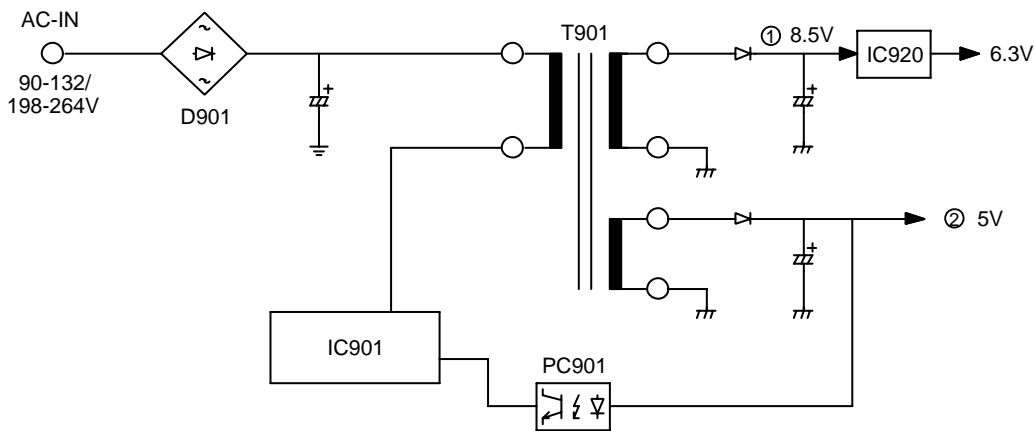
### (3) SUB POWER circuit

When AC input is supplied to SUB POWER circuit, start-up resistor R908 and R909 detect 4 pin of IC901 voltage (VCC-IN) and activate internal start circuit of IC901. When pin 4 of IC901 voltage turns to 16V, internal control circuit starts operation and auxiliary coil voltage between 2 and 3 pin of T901 (sub transformer) is up to approx. 18V, and SUB POWER circuit is activated.

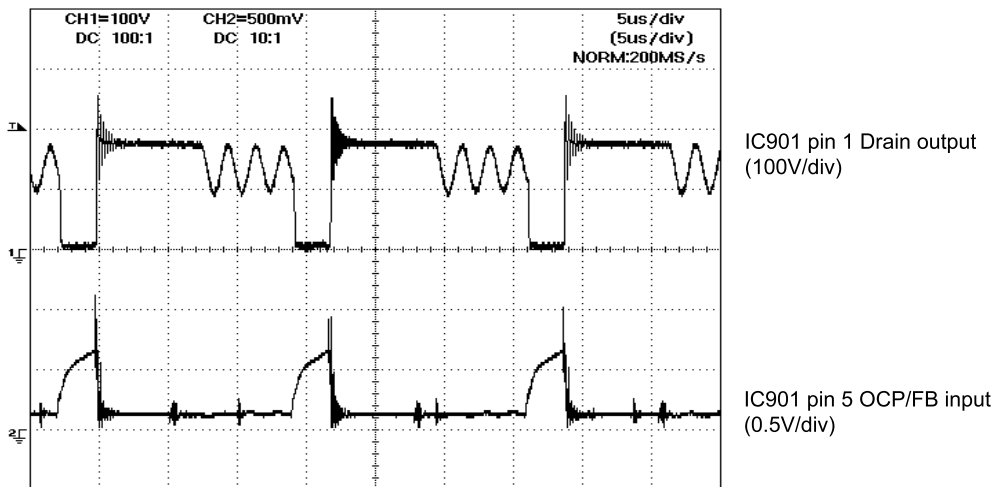
IC950 detects the load of 5V output voltage from the T901 secondary and controls the feedback current in PC901 (photocoupler) by fed back to 5 pin of IC951 (OCP/FB).

The T901 secondary provides the following DC voltages:

- ① 8.5V line: Supplied to the Heater voltage IC (IC920) and the Audio-Amp (IC501) as power source.
- ② 5V line: Supplied to the Microprocessor (IC301 and IC104), USB-IC (IC701), SW-IC (IC101) and 5V CONTROL circuit as power source.



<Waveform>



**Note:** Above waveform is switching waveform when USB peripherals are not connected.

#### (4) Power management modes

When IC301 (main microprocessor) detects presence of horizontal and vertical sync signal and video signal, control signal is output from IC104 (sub microprocessor). The control signal stops MAIN POWER circuit and decrease heater voltage, and power consumption is reduced.

<Power save control signals>

Mode	Sync signal	PS1	PS2	LED	Circuit
		IC104 pin 8	IC104 pin 15	IC104 pin 13	
Normal	H,V-Sync, VIDEO: ON	HIGH	LOW	HIGH (Green)	All circuits are activated.
Power Management	H,V-Sync, VIDEO: OFF	LOW	HIGH	LOW (Orange)	All circuits except for 5V line stop.

Q920 and K901 (RELAY) are turned off when "LOW" signal is output from 8 pin of IC104. AC input is not supplied to PWB-MAIN when K901 is turned off as K901 switch AC input, and MAIN POWER circuit stops. Q921 is turned off when "HIGH" signal is output from 15 pin of IC104. The output voltage of Heater output IC decrease from 6.3V to 0V. The power consumption is 3W or less.

## 4-2. SYNC SIGNAL PROCESSING circuit

The input sync signal from D-SUB connector is set input condition of VIDEO IN 1 / 2 and sync signal by IC105 (SW-IC) and input to pins 2 (H / HV-IN), 5 (V-IN) and 3 (SOG) of IC101 (Sync-Processor). The input H/V-sync signal is waveform-shaped and kept polarity positive. HV (Comp.) and SOG signals are separated V sync signal. And the input H/V sync signal is output from pins 13 (H-OUT) and 11 (V-OUT) and supplied to pins 41 (H-IN) and 42 (V-IN) of IC301 (Microprocessor), and then output from pins 39 (H-OUT) and 40 (V-OUT) of IC301 and supplied to pins 26 (H-IN) and 27 (V-IN) of IC350 (H/V oscillation IC) to control the horizontal and vertical deflection.

The setting of signal input condition monitors H/V-sync signal applied to IC301, and output SIGNAL SELECT signal from pin 9 of IC104 and S.O.G. switching signal from pin 7 of IC104.

(1) SIGNAL SELECT signal: Set VIDEO-IN 1/2 by controlling pin 13 of IC101.

D-SUB input	IC104 pin 9
VIDEO-IN 1	LOW
VIDEO-IN 2	HIGH

(2) The input sync signal to IC301 is processed by SYNC SIGNAL PROCESSING circuit in IC301 as follows:

- ① Discriminate the input sync signal type: Separate / Composite
- ② Detect the input sync signal presence
- ③ Count the frequency  
Counting criterion: X'TAL 12MHz (X301)

### 4-3. CONTROL circuits

#### (1) HORIZONTAL / VERTICAL OSCILLATION circuit

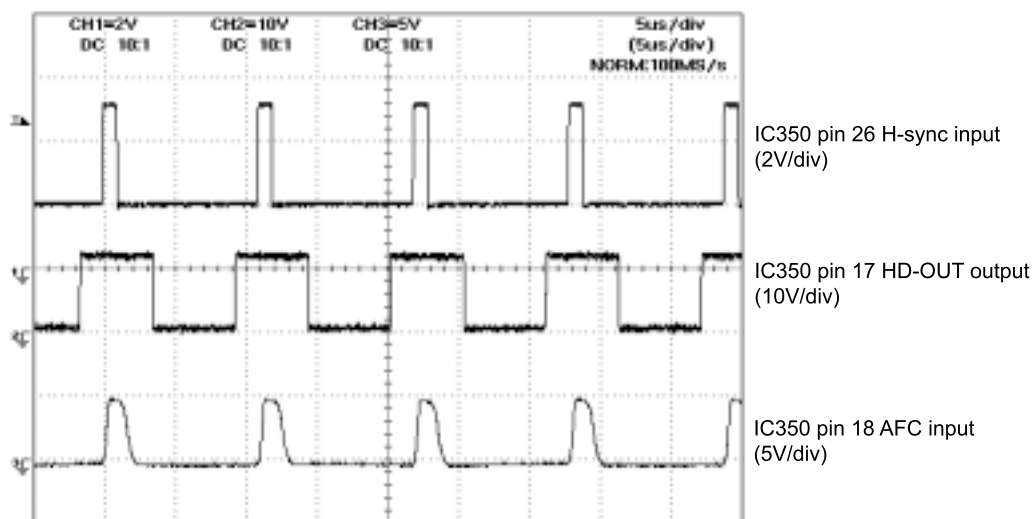
The H/V-sync signal input to IC350 is phase-sifted and converted to the waveform in IC350. The pulse synchronized with the horizontal sync signal is output from pin 17 as horizontal drive pulse. The sawtooth wave synchronized with the vertical sync signal is output from pin 4.

The pulse output from pin 17 generates a frequency locked to the input signal under the following conditions:

- ① The horizontal sync signal is input to pin 26.
- ② The vertical sync signal is input to pin 27.
- ③ The feedback pulse (AFC pulse) of the HORIZONTAL DEFLECTION OUTPUT circuit is input to pin 18.

IC350 (UPC1888FCT) is auto-sync system and adjusts the horizontal frequency automatically make the vertical sync signal input to pin 27 trigger. In case that the AFC pulse is not input, the output pulse from pin 17 is unlocked and the horizontal picture size changes with keeping it small and picture is not synchronized.

<Horizontal Waveform>

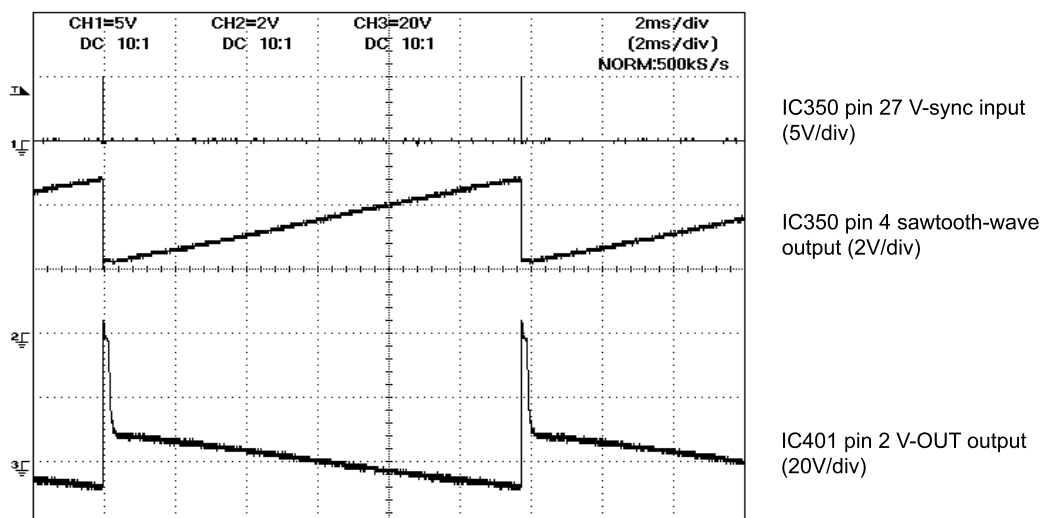


#### (2) VERTICAL DEFLECTION circuit

The sawtooth wave output from pin 4 of IC350 is amplified by IC401 (V-OUT-IC) and then supplied to the deflection yoke as a vertical deflection current to control the vertical deflection.

V-position is controlled by changing the DC component of the sawtooth wave output from pin 4.

<Vertical Waveform>

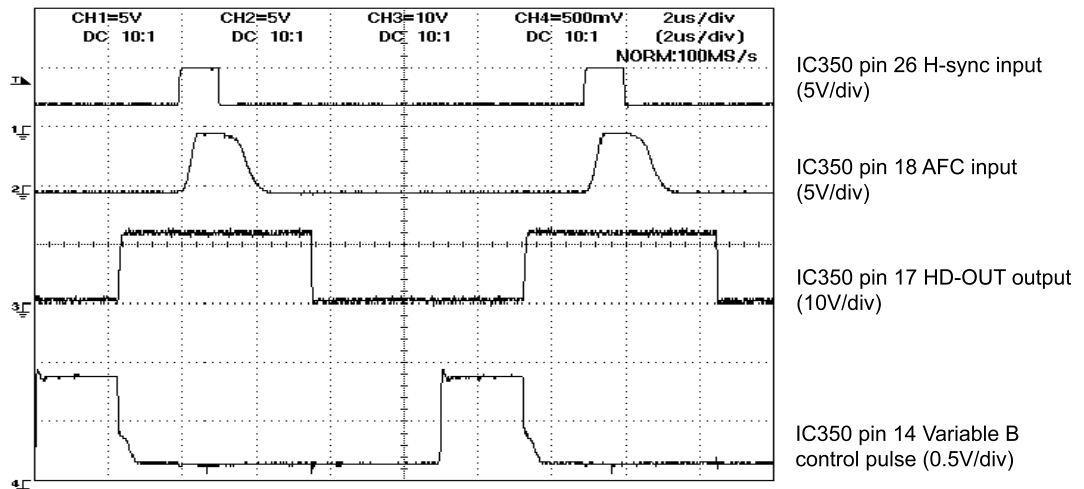
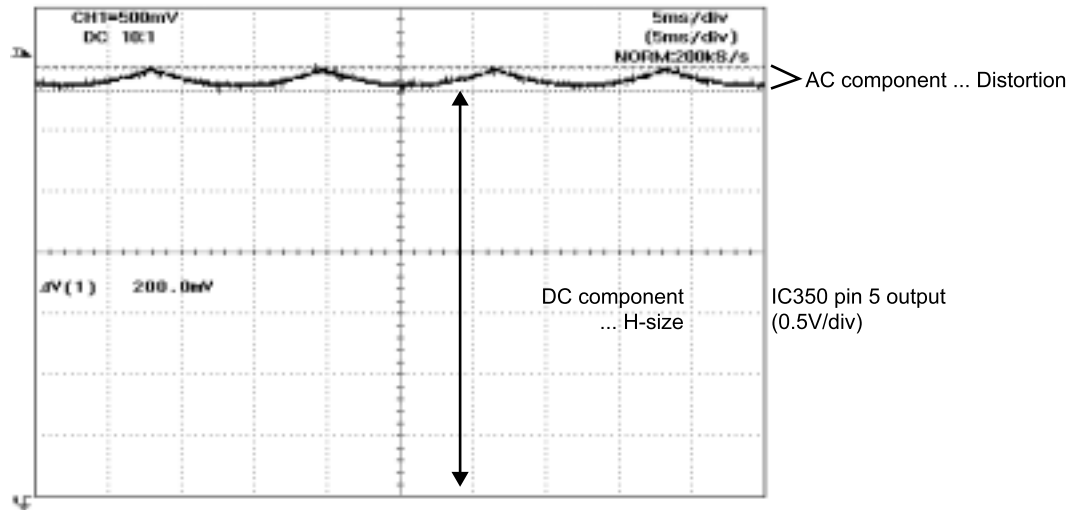


### (3) HORIZONTAL SIZE and DISTORTION CONTROL circuits

The variable B voltage control pulse synchronized with the horizontal sync signal is output from pin 14 of IC350. The control pulse makes the PRESSOR CHOPPER circuit consisted of L955, Q951 and D964 output the variable B voltage of horizontal deflection output.

The horizontal size control voltage and distortion control parabolic wave output from pin 5 are input to pin 11 and then the output pulse of pin 14 controls the horizontal size and distortion as follows:

- ① H-size: The output duty of pin 14 is varied by the DC voltage input to pin 11.
- ② Distortion: The parabolic wave (AC component) input to pin 11 is synthesized with the output pulse of pin 14.

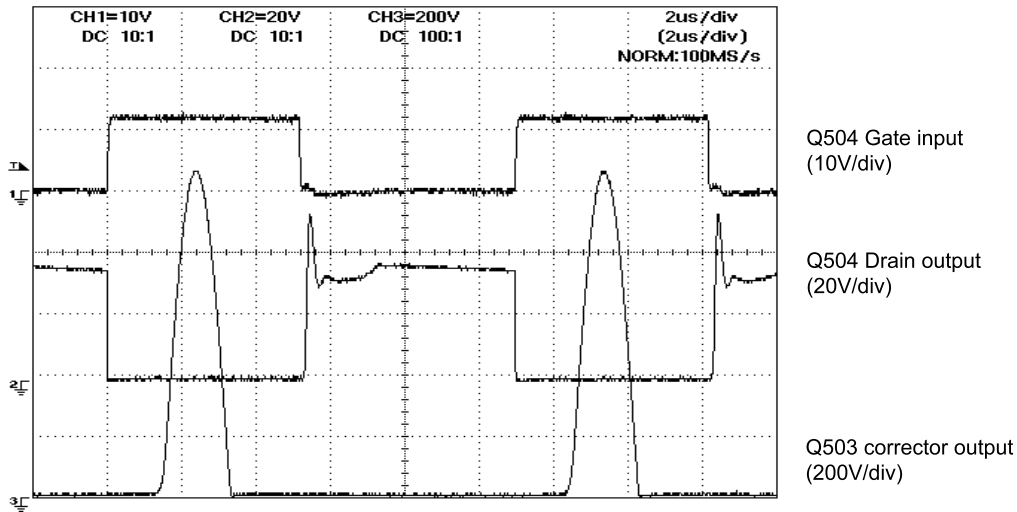


## 4-4. HORIZONTAL DEFLECTION circuit

### (1) HORIZONTAL DRIVE circuit

The horizontal drive pulse output from pin 17 of IC350 is amplified by Q504 and T502 and then supplied to Q503 (H-OUT) base as a current.

The current is amplified by Q503 and then supplied to the deflection yoke as a horizontal deflection current to control the horizontal deflection.



### (2) HORIZONTAL LINEARITY CORRECTION circuit

The switching signal from IC301 controls H-LIN-COIL (L503, L504 and L507), S-correction capacitor (C510, C511, C512, C513, C514 and C557) and FET-ARRAY (IC502), and then correct linearity every frequency.

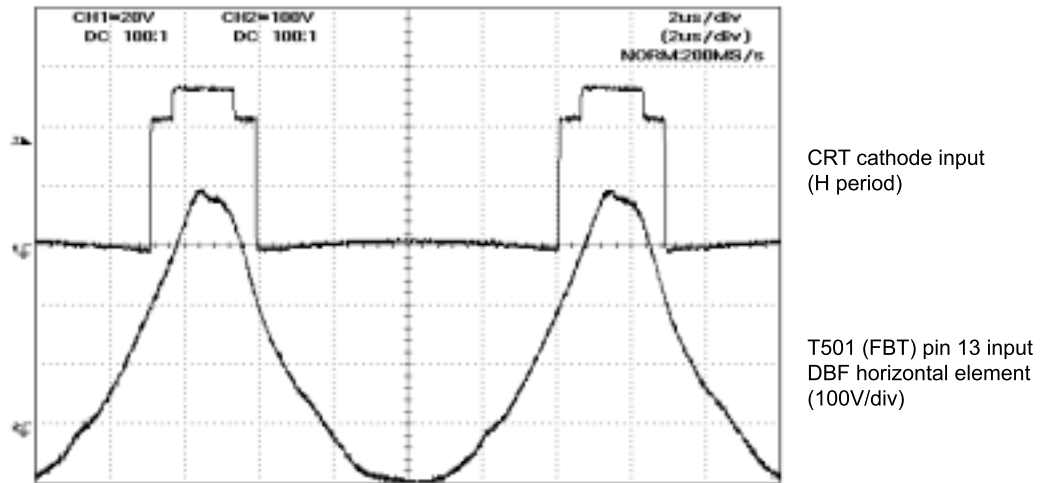
Each switching point performs horizontal linear and distortion correction as follows:

fH (kHz)	IC301 output pin								
	CS1 (Pin 6)	CS2 (Pin 7)	CS3 (Pin 9)	CS4 (Pin 15)	CS5 (Pin 16)	CS6 (Pin 17)	H-LIN1 (Pin 34)	H-LIN2 (Pin 25)	DRIVE (Pin 26)
30.0 - 34.0	LOW	LOW	LOW	LOW	LOW	LOW	LOW	LOW	LOW
34.1 - 41.0	LOW	HIGH	LOW	HIGH	HIGH	HIGH	LOW	LOW	LOW
41.1 - 45.0	HIGH	LOW	LOW	LOW	LOW	LOW	LOW	LOW	LOW
45.1 - 49.0	HIGH	LOW	LOW	HIGH	HIGH	HIGH	LOW	HIGH	HIGH
49.1 - 59.0	HIGH	LOW	HIGH	LOW	HIGH	LOW	LOW	HIGH	HIGH
59.1 - 66.0	HIGH	HIGH	LOW	LOW	LOW	LOW	LOW	HIGH	HIGH
66.1 - 73.0	HIGH	HIGH	LOW	HIGH	LOW	HIGH	LOW	HIGH	HIGH
73.1 - 84.0	HIGH	HIGH	HIGH	LOW	LOW	LOW	LOW	HIGH	HIGH
84.1 - 88.5	HIGH	HIGH	HIGH	LOW	HIGH	LOW	LOW	HIGH	HIGH
88.6 - 97.0	HIGH	HIGH	HIGH	HIGH	LOW	LOW	HIGH	HIGH	HIGH
97.1 - 115.0	HIGH	HIGH	HIGH	HIGH	HIGH	LOW	HIGH	HIGH	HIGH
115.1-130.0	HIGH	HIGH	HIGH	HIGH	HIGH	HIGH	HIGH	HIGH	HIGH

## 4-5. DYNAMIC BEAM FOCUS (DBF) circuit

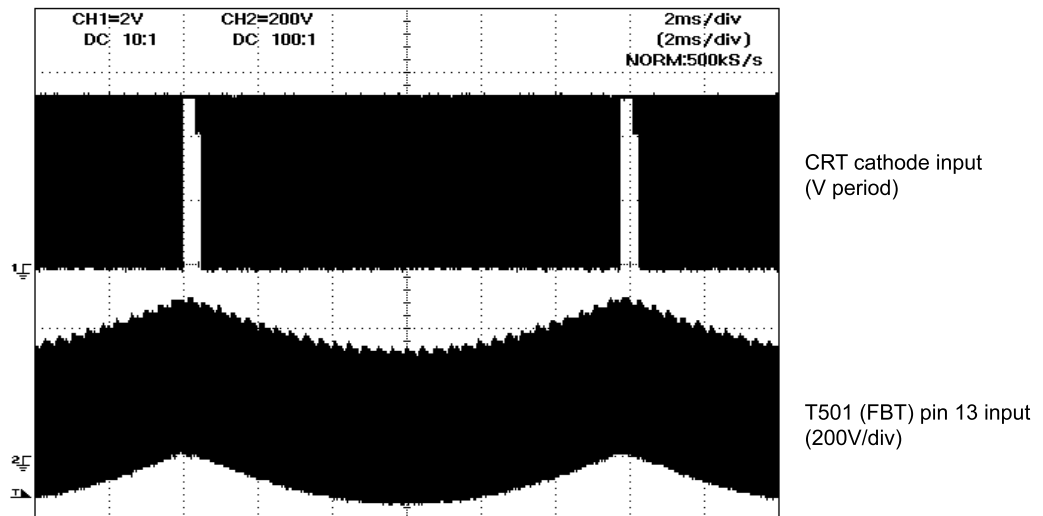
### (1) H-DBF

The parabolic wave of horizontal period is output from pin 9 of IC350 (HDFO) and then amplified by Q516 and Q517. It increases up to approx. 500Vp-p by T503 and synthesized with V-parabolic wave and then applied to pin 13 (DF) of T501 (FBT).



### (2) V-DBF

The parabolic wave of vertical period is output from pin 8 of IC350 (VDFO) and then amplified by Q520. It is synthesized with H-parabolic wave.



## 4-6. VIDEO circuit

### (1) Pre-amp

The video signal from D-SUB connector via IC101 (SW-IC) is input to pins 1 (R-IN), 3 (G-IN) and 6 (B-IN) of IC201 pre-amplifier. This video signal is clamped by clamp signal input to pin 13 of IC201. The blanking signal input to pin 14 is synthesized with the clamped signal and then output from pins 29 (R-OUT), 27 (G-OUT) and 25 (B-OUT) respectively.

V-BLK signal: Remove the raster retrace line.

H-BLK signal: Remove the side raster rolling.

I<sup>2</sup>C-BUS controls D/A converter in IC201 as follows:

- ① Contrast
- ② Sub-brightness
- ③ R/G/B drive
- ④ OSD contrast
- ⑤ D/A output for the CUT-OFF circuit
- ⑥ Gamma correction
- ⑦ Sharpness correction

### (2) ABL

DC voltage input to pin 7 of IC201 controls the amplitude of the video output signal. Therefore, it controls the FBT beam current.

ABL is activated (entire white raster): Approx. 3.5VDC at pin 7

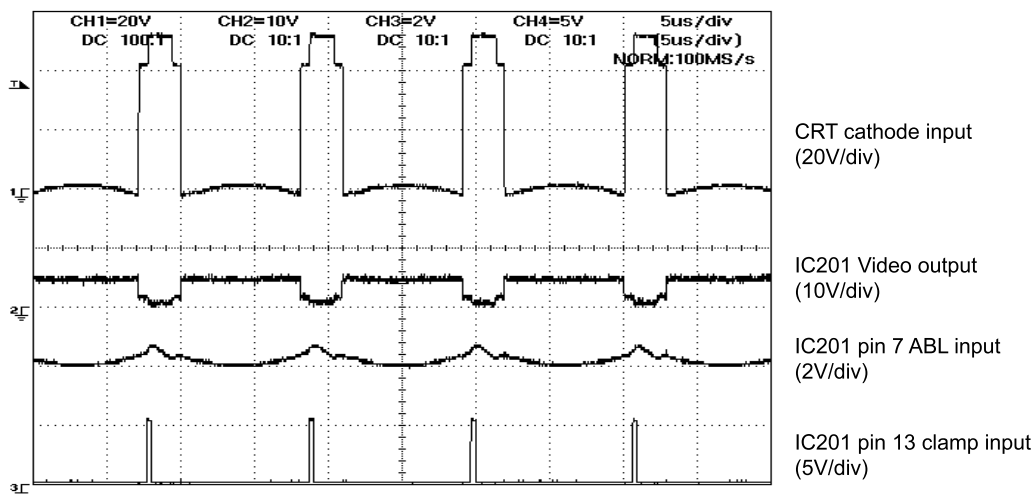
ABL is not activated (window): Approx. 4.1VDC at pin 7

The parabolic waveform is added to video output signal by synthesizing the H-DBF parabolic waveform from Q301 and it corrects a luminance difference between the left and right side of the picture.

### (3) VIDEO-OUT and CUT-OFF circuits

The video signal input to pins 9 (R-IN), 8 (G-IN) and 11 (B-IN) of IC202 (VIDEO-OUTPUT) is amplified reversely and then output from pins 3 (R-OUT), 5 (G-OUT) and 1 (B-OUT) respectively.

The R/G/B-cut-off and brightness D/A control voltages output from pins 18-21 of IC201 pre-amplifiers are amplified by IC204 (CUT-OFF-IC), and then added to the video signal from IC202 and supplied to the CRT cathode grid.

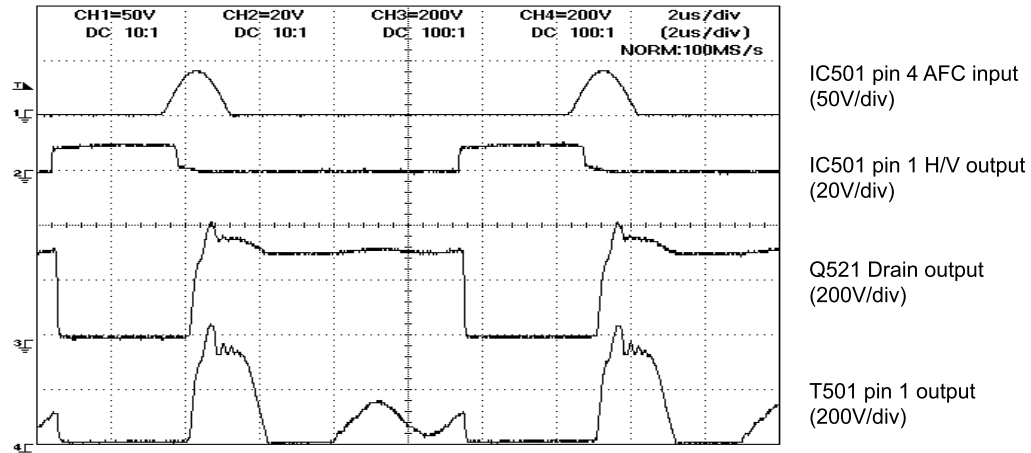




## 4-7. HIGH VOLTAGE CONTROL / OUTPUT circuit

The AFC pulse output from the HORIZONTAL DEFLECTION OUTPUT (L501 pin 9) applied to pin 4 of IC501 (HV-CONT-IC) and then a control pulse synchronized with the frequency of the AFC pulse is output from pin 1 of IC501 and operate Q521 (HV-OUT).

For stabilizing high voltage output control, this circuit is to detect a feedback voltage from pin 11 of T501 (FBT) and feed back to pin 6 of IC501, change the output duty of pin 1 of IC501, and control the high voltage change due to the brightness changes.



## 4-8. PROTECTION circuit

This circuit is composed of the following protection circuits to prevent a damage to the monitor and X-ray radiation when the monitor is inoperative.

When the circuit is in the following cases, pin 19 of IC350 (XRAY) turns to 5V and then the horizontal drive pulse output from pin 17 and the variable B control pulse output from pin 14 turn to "LOW" level (0V). It makes the HORIZONTAL DEFLECTION OUTPUT and the HIGH VOLTAGE OUTPUT circuits stop.

The signal that the X-RAY PROTECTION circuit is activated is sent to IC301 (Main Microprocessor) from IC350 by I<sup>2</sup>C-BUS when pin 19 turns to 5V. IC301 receives the signal and then PS1 signal of pin 8 of IC104 turns to "LOW" level and PS2 signal of 15 pin of IC104 turns to "HIGH" so that the MAIN POWER circuit is turned off.

In case that the PROTECTION circuit is activated and the HORIZONTAL DEFLECTION OUTPUT, HIGH VOLTAGE OUTPUT and MAIN POWER circuits are turned off, turn OFF and ON the Power Switch to recover.

The PROTECTION circuit operates in the following cases:

- ① +B9 line: The voltage is 220V or more.
- ② X-RAY PROTECTION circuit: The high voltage is 29.0kV or more.
- ③ ARC LIMIT circuit: The beam current in FBT is 3.0mA or more.

## 4-9. CRT CORRECTION circuit

Following adjustment and functions are for CRT correction.

- ① H/V-CONVERGENCE
- ② TILT-DY
- ③ NS-RRC
- ④ Landing (TR/TL/BR/BL)

### (1) H/V-CONVERGENCE and TILT-DY

The signal input to IC205 (D/A) from IC301 (Main Microprocessor) by I<sup>2</sup>C -BUS is output from pins 2 (TILT), 3 (H-CONV), 4 (V-CONV) and vary the current applied to each coils built-in deflection yoke by IC206 and IC207 (POWER-OP-AMP). It makes H/V-CONVERGENCE and TILT-DY change.

### (2) NS-RRC

The signal input to pins 18 and 19 of IC301 from IC304 (Terrestrial magnetic sensor) and applied to IC205, and output from pin 1 of IC205, and vary the current in NS-COIL by IC206. It makes NS-RRC change.

### (3) Landing

TH150 (thermistor) detects the set surrounding temperature and CT connector (thermistor) detects the CRT temperature of funnel. These correct the landing temperature.

The information of the CRT temperature of funnel is received at pin 20 of IC301 and the information of surrounding temperature is received at pin 4 of IC104, and then sent to IC301 by I<sup>2</sup>C-BUS. The information is output from pins 10, 11, 12 and 13 of IC301 as pulse width modulation and vary the current in Landing correction coil (TR/TL/BR/BL) by IC801 and IC802 (POWER-OP-AMP). It makes Landing change.

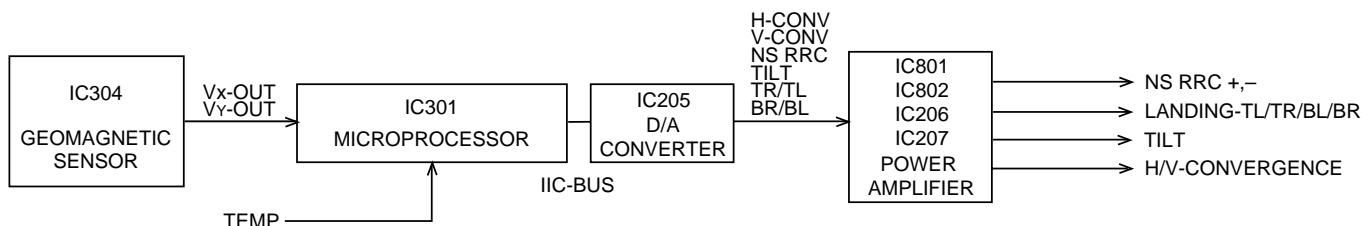
## 4-10. LANDING CORRECTION circuit

This circuit detects the followings to correct LANDING discoloration.

- Magnetic field..... TERRESTRIAL MAGNETIC SENSOR (IC304) detects the magnetic field.
- SWITCH ON DRIFT.....TH801 detects surrounding temperature. Thermistor attached to the funnel detects the temperature of funnel.
- Surrounding temperature.....TH801 detects surrounding temperature.

When the above condition is changed, the MICROPROCESSOR (IC301) informs the change to the D/A CONVERTER (IC205). The output signal from IC205 is amplified by IC801, IC802, IC206 and IC207 to correct LANDING discoloration automatically by the coils N-S RRC, TL, TR, BL and BR.

The LANDING correction also can be performed with the front buttons.



## 4-11. AUDIO circuit

The audio signal from CN602 (AUDIO-IN) is amplified by IC601 (AUDIO-AMP) and output to Speaker and Headphone jack.

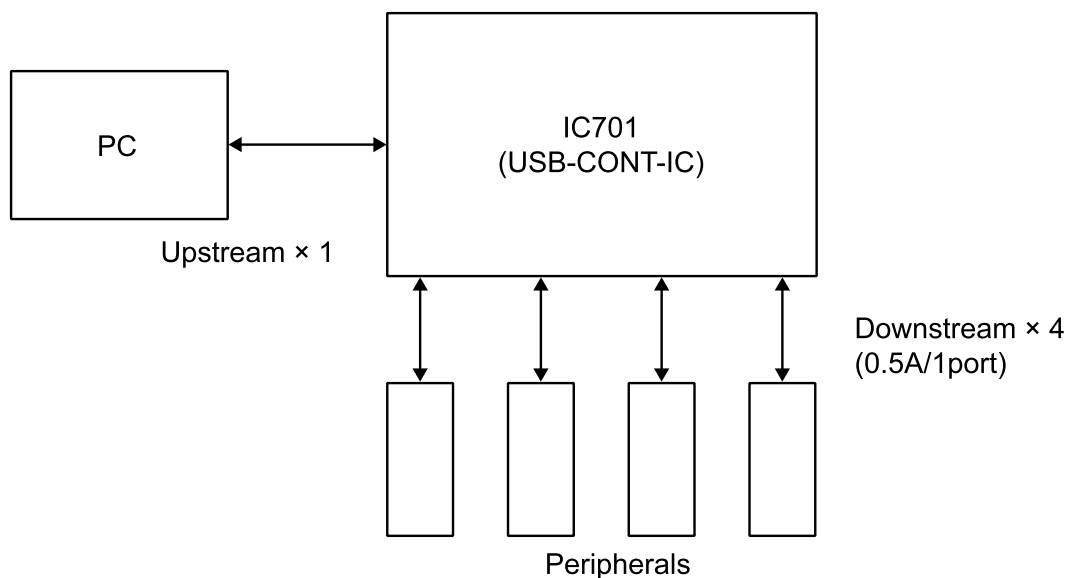
The VR voltage (0-1.2V) from pin 9 of IC601 switch output of pins 6, 10, 11 and 12 of IC104 to HIGH and LOW to control the volume.

IC601 stops when Q601 is turned on under the power management mode.

Level	Input Voltage IC601 pin 9	IC104 output pin			
		Pin 6	Pin 10	Pin 11	Pin 12
0	0.020	LOW	LOW	LOW	LOW
1	0.046	HIGH	LOW	LOW	LOW
2	0.073	LOW	HIGH	LOW	LOW
3	0.104	HIGH	HIGH	LOW	LOW
4	0.135	LOW	LOW	HIGH	LOW
5	0.172	HIGH	LOW	HIGH	LOW
6	0.211	LOW	HIGH	HIGH	LOW
7	0.256	HIGH	HIGH	HIGH	LOW
8	0.292	LOW	LOW	LOW	HIGH
9	0.346	HIGH	LOW	LOW	HIGH
10	0.404	LOW	HIGH	LOW	HIGH
11	0.473	HIGH	HIGH	LOW	HIGH
12	0.546	LOW	LOW	HIGH	HIGH
13	0.636	HIGH	LOW	HIGH	HIGH
14	0.736	LOW	HIGH	HIGH	HIGH
15	0.861	HIGH	HIGH	HIGH	HIGH

## 4-12. USB circuit

This circuit detects connecting condition of the upstream port (CN701 UP) from PC and the downstream port (CN702 and CN703) from peripherals and communicate with PC by IC701 (USB-CONT-IC). USB cable (series A/B) is composed of 5V, GND, +D and -D signals. The condition of connection is judged from by detecting data transfer rate of peripherals connected by +D and -D combination at IC701. (The condition of connection is detected whether +D and -D signals are pulled up or not.)



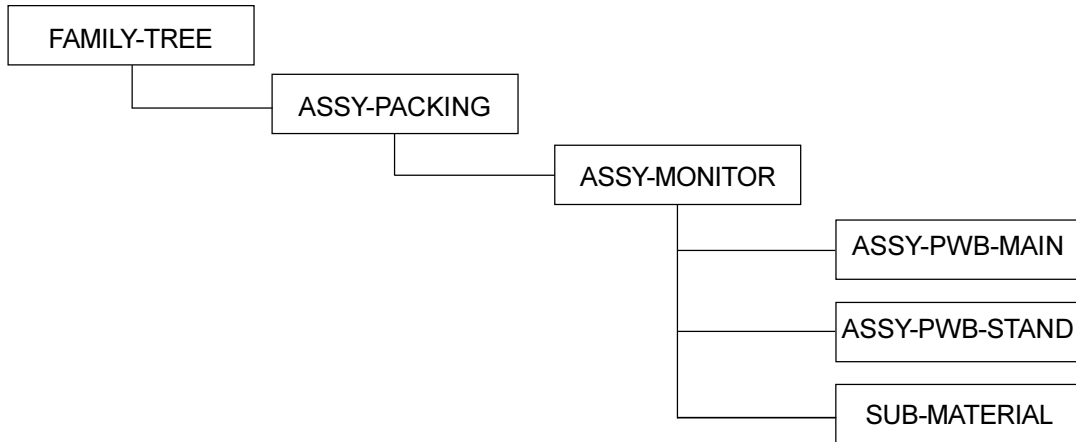
# 5. SERVICE PARTS LIST

**WARNING !**  
The components identified by " !" in this manual are critical for safety.  
Replace only with part number specified .

< Contents >

	-Page-
Abbreviations and Marks.....	32
FAMILY-TREE.....	33
ASSY-PACKING.....	33
ASSY-MONITOR.....	34-35
ASSY-PWB-MAIN.....	36-45
ASSY-PWB-STAND.....	46-55
SUB-MATERIAL.....	56

< Structure >



## ELECTRICAL PARTS LIST

< Abbreviations in PART section >

Abbreviation	Meaning
R-C	Resistor-Carbon
R-MB	Resistor-Metal
R-FUSE	Resistor-Fuse
C-C	Capacitor-Ceramic
C-E	Capacitor-Electrolytic
C-PP	Capacitor-Polypropylene
C-MF	Capacitor-Multilayer Metallized Polyester Film
D	Diode
ZD	Zener Diode
TR	Transistor
PHC	Photo Coupler
PTH	Positive Thermistor
HDT	Horizontal Drive Transformer
FBT	Flyback Transformer
VR	Variable Resistor
SW	Switch
SWT	Switching Transformer

< Marks in DESCRIPTION section >

< Resistor >

Mark	Tolerance
F	± 1%
J	± 5%
K	±10%

< Capacitor >

Mark	Tolerance
H	± 3%
J	± 5%
K	± 10%
M	± 20%
P	+100%
	- 0%
Z	+ 80%
	- 20%

**DWG. TITLE : FAMILY-TREE**

GROUP 10: HM903DT, 20: A902MT-v

GROUP		REV.	REF.NO	PART	DESCRIPTION	PART NO.	PRICE	REMARK
20	10							
0	1			ASSY-PACKING	(HNE)	T985T044-20		
0	1			ASSY-PACKING	(HNB)	T985T044-30		
0	1			ASSY-PACKING	(LNN)	T985T044-40		
1	0			ASSY-PACKING	(HNE)	T985T044-60		
1	0			ASSY-PACKING	(HNB)	T985T044-70		
1	0			ASSY-PACKING	(LNN)	T985T044-80		
0	1			ASSY-MONITOR		T950R117-20		
1	0			ASSY-MONITOR		T950R117-40		
0	1			ASSY-PWB-MAIN		T950T070-10		
1	0			ASSY-PWB-MAIN		T950T070-20		
1	1			ASSY-PWB-STAND		T950T071-10		
1	1			SUB-MATERIAL		951V001-10		

**DWG. TITLE : ASSY-PACKING**

GROUP 10: HM903DT, 20: A902MT-v

GROUP		REV.	REF.NO	PART	DESCRIPTION	PART NO.	PRICE	REMARK
20	10							
0	1		15	RATING-PLATE		706Z071-01		!
1	0		17	RATING-PLATE		706Z073-01		!
0	1		22	SERIAL-LABEL		851T013-55		!
1	0		24	SERIAL-LABEL		851T013-57		!
1	1		29	OPERATION-MANUAL		870Z172-01		!
1	1		33	SIGNAL-CABLE		242Z013-01		!
1	1		34	SIGNAL-CABLE		242Z027-01		!
1	1		35	AUDIO-CABLE		242Z028-01		!
1	1		40	PACKING-CASE		800Z047-02		
1	1		43	ATTENTION-SHEET		870Z112-01		!
2	2		46	LABEL		851Z018-01		
0	1		47	LABEL		851Z029-01		
1	0		48	LABEL		851Z029-02		
1	1		49	PACKING-BAG		831V005-11		
1	1		52	CUSHION-TOP		803S058-01		
1	1		53	CUSHION-BOTTOM		803S058-02		
#	#		57	CARTON-TAPE	NO.3201/NO.3303M/4266/123 L=4200mm	830Z012A01		
#	#		58	SELLO-TAPE	NO.252/CT07 L=80mm	830Z003A01		
#	#		59	HOLDING-TAPE	NO.3800A L=140mm	830Z005A01		
1	1		62	AC-CORD	(HNE)	500Z005-02		!
1	1		63	AC-CORD	(HNB)	500Z007-02		!
1	1		64	AC-CORD	(LNN9)	500Z012-01		!

**DWG. TITLE : ASSY-MONITOR**

GROUP 10: HM903DT, 20: A902MT-v

GROUP		REV.	REF.NO	PART	DESCRIPTION	PART NO.	PRICE	REMARK
20	10							
0	1		19	FRONT-CABINET		700R079-25		!
1	0		20	FRONT-CABINET		700R079-23		!
1	1		24	BACK-COVER		700R080-22		!
1	1		28	STAND-SUPPORT		770R028-22		!
1	1		32	STAND-BASE		770R029-22		!
1	1		34	CAP-SCREW-L		700T027-03		
1	1		35	CAP-SCREW-R		700T027-04		
2	2		38	HOLDER-SP		700T026-02		
1	1		39	STOP-RING		770T022-02		
1	1		40	CHIP-LED		703T007-01		
1	1		41	BUTTON-PUSH		704S003-02		
1	1		42	RING		700T024-01		
1	1		45	BASE-PLATE		590R154-03		
1	1		46	BOTTOM-PLATE		590R155-01		
1	1		47	SHIELD-CRT-R		590R156-01		
1	1		48	SHIELD-CRT-L		590R156-02		
1	1		49	TOP-PLATE		590R157-01		
1	1		50	SHIELD-MAIN		590R158-01		
1	1		51	SHIELD-COVER-A		590R159-01		
1	1		52	SHIELD-COVER-B		590R160-01		
1	1		53	FRAME-TOP		590S148-01		
1	1		54	SHIELD-COVER-C		590S149-01		
1	1		55	HOLDER-CONT		590T092-01		
1	1		56	COVER-PLATE		590V114-01		
1	1		59	COIL-DEGAUSSING		409Z049-02		!
1	1		60	COIL-CANCEL		409Z050-01		
1	1		61	COIL-CANCEL		409Z051-01		
1	1		62	COIL-CANCEL		409Z051-02		
0	1		65	CRT	M46LRY41X21	251Z062A04		!
1	0		66	CRT	M46LRY21X21	251Z062A03		!
13	13		69	SCREW	STV3*6MC-S	632Z121B06		
11	11		70	SCREW	BTV3*8MC-S	631Z121B08		
9	9		71	SCREW	BTV-SEMS-W3*10MC-S	631Z421B10		
1	1		72	SCREW	BTV-SEMS-W3*14MC-S	631Z421B14		
2	2		73	SCREW	BTV4*10MC-S	631Z121C10		
8	8		74	SCREW	BTV4*16MC-S	631Z121C16		
2	2		75	SCREW	BTF3*8AB-S	631Z113B08		
1	1		76	SCREW	MHA-SEMS-B4*8GR-S	630Z344C08		
4	4		77	SCREW	PTHA-SEMS5*20MC-S	663Z003D20		
4	4		78	SCREW	82007-0300/EHDE-JACKPOST4-40	666Z003A01		
4	4		79	SCREW	STV-SEMS-A3*6MC-S	632Z221B06		
4	4		80	SCREW	MB-SEMS-W3*8MC-S	630Z431B08		
2	2		82	GUM-PAD		683V020-08		
2	2		83	WASHER		683V016-04		
2	2		84	GUM-PAD		683V017-01		
5	5		85	PAD		765V003-01		
3	3		86	GUM-PAD		683V020-04		
1	1		89	INSULATION-SHEET		223V035-01		!
1	1		90	INSULATION-SHEET		223T005-01		!
4	4		94	CLAMPER	SHK-12	540Z080A01		!
3	3		95	CLAMPER	DGC-8.5-19	540Z093A01		!
10	10		96	CLAMPER	DGC-6.5-19	540Z093A02		!
1	1		98	CLAMPER	RLMC-05T	540Z105A02		!
2	2		99	CLAMPER	#3T02/IR-4151-10	540Z077A02		!
10	10		100	CABLE-TIES	GT-100M/TSL-100-M/YJ-100	540Z089A01		!
1	1		104	LEAD-CONNECTOR		246Z018-01		!
1	1		105	LEAD-CONNECTOR		246T097-01		!
1	1		106	LEAD-CONNECTOR		246T097-10		!
1	1		107	LEAD-CONNECTOR		246T097-12		!
1	1		108	LEAD-CONNECTOR		246T090-11		!
1	1		109	LEAD-CONNECTOR		246T090-12		!
8	8		110	LEAD-CONNECTOR		246T097-16		!

**DWG. TITLE : ASSY-MONITOR**

GROUP 10: HM903DT, 20: A902MT-v

GROUP		REV.	REF.NO	PART	DESCRIPTION	PART NO.	PRICE	REMARK
20	10							
2	2		111	LEAD-CONNECTOR		246T097-17		!
1	1		112	EARTH-WIRE		246V022-01		!
1	1		113	LEAD-CONNECTOR		246T097-09		!
1	0		116	LABEL-WARNING		851V109-03		!
0	1		117	LABEL-WARNING		851V109-01		!
1	1		119	AC-INLET		454Z012-01		!
1	1		120	THERMISTOR	103JT-025-00057	744Z006A10		
2	2		121	SPEAKER	NP-220/C057PA504-16/S57C16C-3	883Z011A01		
10	10		122	RIVET	PAD30M3HR-CC	679Z002A01		
3	3		125	SHIELD-FINGER	T10676	590Z028A01		
1	1		126	SHIELD-FINGER	T10689	590Z033A01		
1	1		127	SHIELD-FINGER	T10690	590Z034A01		
1	1		131	FERRITE-CORE	BP53RB/E1620/W5T/RH14	755Z902E20		!
#	#		136	ACETATE-TAPE	NO.570F/AC04 L=120mm+L50mm	830Z014A01		
#	#		137	UL-TAPE	NO.303 L=80mm	830P100A10		
1/10	1/10		140	SPOILER	E	890Z003A05		
1	1		141	SPOILER	C	890Z003A03		



**DWG. TITLE : ASSY-PWB-MAIN**

GROUP 10: HM903DT, 20: A902MT-v

GROUP		REV.	REF.NO	PART	DESCRIPTION	PART NO.	PRICE	REMARK
20	10							
1	1		12	RADIATOR-M		590S145-01		
1	1		13	RADIATOR		590V091-01		
1	1		14	RADIATOR		590V097-04		
1	1		15	RADIATOR-P		590T089-01		
1	1		16	SHIELD-IC		590T090-01		
1	1		19	CLAMPER	SHK-12	540Z080A01		!
2	2		20	CABLE-TIES	GT-100M/TSL-100-M/YJ-100	540Z089A01		!
3	3		21	LEAD-WIRE		246Z004-02		!
1	1		24	SCREW	BTV3*8MC-S	631Z121B08		
3	3		25	SCREW	MP-SEMS-W3*8MC-S	630Z401B08		
14	14		26	SCREW	MP-SEMS-W3*10MC-S	630Z401B10		
1	1		30	LEAD-CONNECTOR		246T097-02		!
1	1		31	LEAD-CONNECTOR		246T097-04		!
1	1		32	LEAD-CONNECTOR		246T097-13		!
1	1		33	LEAD-CONNECTOR		246T097-05		!
2	2		34	LEAD-CONNECTOR		246T097-06		!
1	1		35	LEAD-CONNECTOR		246T097-07		!
1	1		36	LEAD-CONNECTOR		246T097-08		!
1	1		37	LEAD-CONNECTOR		246T097-03		!
1	1		40	COOL-SHEET		222V024-01		!
1	1		41	COOL-SHEET		222V025-01		!
1	1		42	COOL-SHEET	M-20	222Z001A02		!
1	1		45	FERRITE-CORE	BP53RB/FSOB162RN/E1620MRT/W5T	755Z902E10		!
1	1		50	LEAD-WIRE		246V027-01		
1	1		51	LEAD-WIRE		246V027-02		
1	1		52	LEAD-WIRE		246V027-03		
1	1		53	LEAD-WIRE		246V027-04		
1	1		C301	C-E	25V 220M-M	460Z221B43		
1	1		C302	C-C-CHIP	25V F-R1M-Z	411Z104B44		
1	1		C303	C-E	25V 220M-M	460Z221B43		
1	1		C304	C-C-CHIP	25V F-R1M-Z	411Z104B44		
1	1		C306	C-C-CHIP	25V F-R1M-Z	411Z104B44		
1	1		C307	C-E	25V 100M-M	460Z101B43		
1	1		C308	C-C-CHIP	25V F-R1M-Z	411Z104B44		
1	1		C309	C-C-CHIP	25V F-R1M-Z	411Z104B44		
1	1		C310	C-E	25V 100M-M	460Z101B43		
1	1		C311	C-E	25V 100M-M	460Z101G43		
1	1		C312	C-C-CHIP	50V CH-27P-J	410Z270B14		
1	1		C313	C-C-CHIP	50V CH-22P-J	410Z220B14		
1	1		C314	C-C-CHIP	25V F-R1M-Z	411Z104B44		
1	1		C315	C-C-CHIP	25V F-R1M-Z	411Z104B44		
1	1		C316	C-C-CHIP	25V F-R1M-Z	411Z104B44		
1	1		C317	C-C-CHIP	25V F-R1M-Z	411Z104B44		
1	1		C318	C-E	16V 470M-M	460Z471B33		
1	1		C319	C-C-CHIP	50V B-1000P-K	411Z102B14		
1	1		C320	C-C-CHIP	25V F-R1M-Z	411Z104B44		
1	1		C321	C-C-CHIP	25V F-R1M-Z	411Z104B44		
1	1		C322	C-C-CHIP	25V F-R1M-Z	411Z104B44		
1	1		C323	C-C-CHIP	25V F-R1M-Z	411Z104B44		
1	1		C324	C-C-CHIP	25V F-R1M-Z	411Z104B44		
1	1		C325	C-C-CHIP	25V F-R1M-Z	411Z104B44		
1	1		C326	C-E	25V 100M-M	460Z101B43		
1	1		C327	C-E	25V 100M-M	460Z101B43		
1	1		C328	C-E	25V 100M-M	460Z101B43		
1	1		C329	C-E	25V 100M-M	460Z101B43		
1	1		C331	C-C-CHIP	25V F-R1M-Z	411Z104B44		
1	1		C332	C-C-CHIP	25V F-R1M-Z	411Z104B44		
1	1		C333	C-C-CHIP	25V F-R1M-Z	411Z104B44		
1	1		C334	C-E	25V 100M-M	460Z101B43		
1	1		C335	C-E	25V 100M-M	460Z101B43		
1	1		C350	C-E	16V 470M-M	470Z471T33		
1	1		C351	C-C-CHIP	25V F-R1M-Z	411Z104B44		

**DWG. TITLE : ASSY-PWB-MAIN**

GROUP 10: HM903DT, 20: A902MT-v

GROUP		REV.	REF.NO	PART	DESCRIPTION	PART NO.	PRICE	REMARK
20	10							
1	1		C354	C-E	50V 3R3M-M	470Z339G63		
1	1		C355	C-E	100V 1M-M	470Z109T83		
1	1		C356	C-C-CHIP	50V B-2200P-K	411Z222B14		
1	1		C357	C-E	100V 1M-M	470Z109T83		
1	1		C358	C-E	25V 33M-M	470Z330T43		
1	1		C359	C-C-CHIP	50V B-R033M-K	411Z333B14		
1	1		C360	C-E	16V 1000M-M	470Z102G33		
1	1		C361	C-C-CHIP	25V F-R1M-Z	411Z104B44		
1	1		C362	C-E	25V 220M-M	470Z221T43		
1	1		C363	C-C-CHIP	25V F-R1M-Z	411Z104B44		
1	1		C364	C-C-CHIP	50V B-R033M-K	411Z333B14		
1	1		C365	C-E	25V 100M-M	460Z101B43		
1	1		C366	C-C-CHIP	50V CH-390P-J	410Z391B14		
1	1		C367	C-C-CHIP	50V CH-1200P-J	410Z122B14		
1	1		C369	C-C-CHIP	50V CH-1000P-J	410Z102B14		
1	1		C370	C-C-CHIP	50V CH-1000P-J	410Z102B14		
1	1		C371	C-C-CHIP	25V F-R1M-Z	411Z104B44		
1	1		C372	C-C-CHIP	50V CH-22P-J	410Z220B14		
1	1		C373	C-C-CHIP	50V CH-22P-J	410Z220B14		
1	1		C374	C-C-CHIP	25V F-R1M-Z	411Z104B44		
1	1		C375	C-E	50V 10M-M	470Z100G63		
1	1		C377	C-E	25V 100M-M	470Z101T43		
1	1		C378	C-C-CHIP	25V F-R1M-Z	411Z104B44		
1	1		C379	C-C-CHIP	50V B-1000P-K	411Z102B14		
1	1		C380	C-E	25V 100M-M	470Z101T43		
1	1		C382	C-E	50V 10M-M	470Z100G63		
1	1		C384	C-E	25V 100M-M	470Z101T43		
1	1		C390	C-E	25V 100M-M	460Z101B43		
1	1		C391	C-E	25V 100M-M	460Z101B43		
1	1		C393	C-MF	50V 1000P-J	420Z102E13		
1	1		C401	C-C-CHIP	25V F-R1M-Z	411Z104B44		
1	1		C402	C-E	25V 1000M-M	470Z102G47		
1	1		C403	C-C-CHIP	25V F-R1M-Z	411Z104B44		
1	1		C404	C-E	25V 100M-M	470Z101T43		
1	1		C405	C-C-CHIP	25V F-R1M-Z	411Z104B44		
1	1		C406	C-E	25V 1000M-M	470Z102G47		
1	1		C407	C-MF	100V R22M-J	420Z224E23		
1	1		C408	C-E	35V 100M-M	470Z101T53		
1	1		C410	C-C-CHIP	25V F-R1M-Z	411Z104B44		
1	1		C411	C-C-CHIP	50V F-R01M-Z	411Z103B24		
1	1		C413	C-C-CHIP	50V B-4700P-K	411Z472B14		
1	1		C501	C-PP	1800/2000V1800P-H	424Z182B47		
1	1		C502	C-PP	1800/2000V1800P-H	424Z182B47		
1	1		C504	C-PP	250V 2R2M-J/K	425Z225C17		
1	1		C505	C-C	2KV B-3300P-K	413Z332B43		
1	1		C507	C-C-CHIP	50V B-4700P-K	411Z472B14		
1	1		C508	C-PP	63/100V 10M-K/M	425Z106B37		
1	1		C509	C-C	500V B-680P-K	411Z681B33		
1	1		C510	C-PP	250V 1R2M-J	422Z125C47		
1	1		C511	C-PP	250V R62M-J	422Z624C47		
1	1		C512	C-PP	250V R33M-J	422Z334C47		
1	1		C513	C-PP	250V R082M-J	422Z823C47		
1	1		C514	C-PP	250V R082M-J	422Z823C47		
1	1		C515	C-PP	400V R075M-H	422Z753A37		
1	1		C516	C-PP	400V R075M-H	422Z753A37		
1	1		C517	C-C	500V SL-100P-J	410Z101B43		
1	1		C518	C-MF	100V R47M-J	420Z474E23		
1	1		C519	C-E	100V 1M-M	470Z109T83		
1	1		C520	C-E	50V 22M-M	470Z220T63		
1	1		C521	C-E-NP	25V 10M-M	462Z100F43		
1	1		C522	C-C	500V B-470P-K	411Z471B33		
1	1		C523	C-E	450V 1M-M	461Z109B63		

**DWG. TITLE : ASSY-PWB-MAIN**

GROUP 10: HM903DT, 20: A902MT-v

GROUP		REV.	REF.NO	PART	DESCRIPTION	PART NO.	PRICE	REMARK
20	10							
1	1		C524	C-PP	1000/1250V2200P-J	423Z222B57		!
1	1		C525	C-E	100V 220M-M	470Z221R87		
1	1		C527	C-PP	1000/1250V8200P-J	423Z822B57		
1	1		C528	C-E	25V 1000M-M	460Z102B47		
1	1		C529	C-E	100V 1M-M	460Z109B83		
1	1		C530	C-E	25V 100M-M	460Z101B43		
1	1		C531	C-E	50V R1M-M	460Z108H63		
1	1		C532	C-E-NP	50V 3R3M-M	472Z339F63		
1	1		C533	C-PP	250V R1M-J	422Z104C47		
1	1		C534	C-C-CHIP	25V F-R1M-Z	411Z104B44		
1	1		C537	C-C	500V B-1000P-K	411Z102B33		
1	1		C538	C-MF	50/100V R15M-J	420Z154B83		
1	1		C539	C-E	50V 10M-M	470Z100G63		
1	1		C541	C-E	25V 47M-M	460Z470B43		
1	1		C542	C-E	160V 10M-M	470Z100G93		
1	1		C551	C-C-CHIP	50V F-R01M-Z	411Z103B24		
1	1		C552	C-C-CHIP	50V F-R01M-Z	411Z103B24		
1	1		C553	C-C-CHIP	50V F-R01M-Z	411Z103B24		
1	1		C554	C-C-CHIP	50V F-R01M-Z	411Z103B24		
1	1		C555	C-C-CHIP	50V F-R01M-Z	411Z103B24		
1	1		C556	C-C-CHIP	50V F-R01M-Z	411Z103B24		
1	1		C557	C-PP	250V R056M-J	422Z563C47		
1	1		C559	C-E	25V 220M-M	470Z221T43		
1	1		C563	C-E	50V 2R2M-M	470Z229G63		!
1	1		C564	C-E	50V 3R3M-M	470Z339G63		!
1	1		C566	C-C	500V E-R01M-P/Z	411Z103A07		
1	1		C801	C-E-NP	50V 10M-M	462Z100B63		
1	1		C802	C-C-CHIP	25V F-R1M-Z	411Z104B44		
1	1		C803	C-C-CHIP	25V F-R1M-Z	411Z104B44		
1	1		C804	C-C-CHIP	25V F-R1M-Z	411Z104B44		
1	1		C805	C-C-CHIP	25V F-R1M-Z	411Z104B44		
1	1		C806	C-E-NP	50V 10M-M	462Z100B63		
1	1		C807	C-E	25V 100M-M	470Z101T43		
1	1		C809	C-E	25V 100M-M	470Z101T43		
1	1		C810	C-C-CHIP	25V F-R1M-Z	411Z104B44		
1	1		C811	C-E	25V 100M-M	470Z101T43		
1	1		C812	C-C-CHIP	25V F-R1M-Z	411Z104B44		
1	1		C813	C-E-NP	50V 10M-M	462Z100B63		
1	1		C814	C-C-CHIP	25V F-R1M-Z	411Z104B44		
1	1		C815	C-C-CHIP	25V F-R1M-Z	411Z104B44		
1	1		C816	C-C-CHIP	25V F-R1M-Z	411Z104B44		
1	1		C817	C-C-CHIP	25V F-R1M-Z	411Z104B44		
1	1		C818	C-E-NP	50V 10M-M	462Z100B63		
1	1		C819	C-E	25V 100M-M	470Z101T43		
1	1		C822	C-E	25V 100M-M	470Z101T43		
1	1		C952	SO-COPPER-WIRE		990Z001A11		
1	1		C953	C-PP	630V 1M-K	425Z105C27		
1	1		C954	C-MF	50/100V 4700P-J	420Z472B83		
1	1		C955	C-MF	50V R22M-J	420Z224A13		
1	1		C956	C-C-CHIP	50V F-R01M-Z	411Z103B24		
1	1		C958	C-MF	50V 470P-J	420Z471E13		
1	1		C959	C-E	450V 220M-M	467Z009A10		!
1	1		C960	C-PP	630V R022M-K	425Z223C27		
1	1		C961	C-C	2KV B-220P-K	413Z221B43		
1	1		C962	C-E	100V 220M-M	470Z221G87		
1	1		C963	C-E	35V 1000M-M	470Z102G57		
1	1		C964	C-E	25V 100M-M	460Z101B43		
1	1		C965	C-C-CHIP	50V CH-470P-J	410Z471B14		
1	1		C967	C-C-CHIP	50V CH-470P-J	410Z471B14		
1	1		C968	C-C	AC250V 2200P-M	510Z012A16		!
1	1		C970	C-C-CHIP	25V F-R1M-Z	411Z104B44		
1	1		C971	C-E	25V 100M-M	460Z101B43		

**DWG. TITLE : ASSY-PWB-MAIN**

GROUP 10: HM903DT, 20: A902MT-v

GROUP		REV.	REF.NO	PART	DESCRIPTION	PART NO.	PRICE	REMARK
20	10							
1	1		C972	C-E	25V 100M-M	460Z101B43		
1	1		C973	C-C	2KV B-100P-K	413Z101B43		
1	1		C974	C-C	500V B-330P-K	411Z331B33		
1	1		C975	C-C-CHIP	50V B-1000P-K	411Z102B14		
1	1		C976	C-C-CHIP	50V CH-470P-J	410Z471B14		
1	1		C978	C-E	35V 1000M-M	470Z102G57		
1	1		C979	C-C-CHIP	25V F-R1M-Z	411Z104B44		
1	1		C980	C-C-CHIP	50V B-R033M-K	411Z333B14		
1	1		C981	C-C-CHIP	50V F-R01M-Z	411Z103B24		
1	1		C982	C-C	2KV B-220P-K	413Z221B43		
1	1		C983	C-E	100V 470M-M	470Z471G87		
1	1		C984	C-C	500V E-R01M-P/Z	411Z103A07		
1	1		C985	C-C	2KV B-220P-K	413Z221B43		
1	1		C986	C-E	35V 2200M-M	470Z222U57		
1	1		C987	C-C-CHIP	50V F-R01M-Z	411Z103B24		
1	1		C988	C-C	2KV B-220P-K	413Z221B43		
1	1		C989	C-E	25V 2200M-M	470Z222U47		
1	1		C990	C-C-CHIP	25V F-R1M-Z	411Z104B44		
1	1		C991	C-C	2KV B-220P-K	413Z221B43		
1	1		C992	C-E	25V 1000M-M	470Z102U47		
1	1		C993	C-C-CHIP	25V F-R1M-Z	411Z104B44		
1	1		C994	C-E	50V 100M-M	470Z101G63		
1	1		C995	C-C	2KV B-220P-K	413Z221B43		
1	1		C996	C-C-CHIP	50V F-R01M-Z	411Z103B24		
1	1		C997	C-E	50V 10M-M	470Z100G63		
1	1		C998	C-C-CHIP	25V F-R1M-Z	411Z104B44		
1	1		C999	C-E	25V 47M-M	460Z470B43		
1	1		C9A1	C-E	25V 1000M-M	470Z102G47		
1	1		C9A2	C-C-CHIP	50V B-R1M-K	411Z104C14		
1	1		C9A4	C-C-CHIP	50V F-R01M-Z	411Z103B24		
1	1		D307	D	1N4148/1SS133/1SS120	742Z001A21		
1	1		D321	ZD	MTZ-J4.7B/HZ5B1	742Z414A21		
1	1		D322	ZD	MTZ-J4.7B/HZ5B1	742Z414A21		
1	1		D350	ZD	MTZ-J4.7B/HZ5B1	742Z414A21		
1	1		D351	SO-COPPER-WIRE		990Z001A11		
1	1		D401	D	EM01Z/D1N60/1N4003	742Z019A31		
1	1		D402	D	1N4148/1SS133/1SS120	742Z001A21		
1	1		D403	D	RB441Q/1SS165-03/SR104	742Z026A21		
1	1		D501	D	5VUZ47	742Z063A15		
1	1		D502	D	RC3B2	742Z032A17		
1	1		D503	ZD	HZT33-10	742Z408A11		!
1	1		D504	D	EM01Z/D1N60/1N4003	742Z019A31		
1	1		D505	D	EM01Z/D1N60/1N4003	742Z019A31		
1	1		D506	ZD	P6KE82/Z2082U	742Z419A21		
1	1		D511	D	5VUZ47	742Z063A15		
1	1		D512	D	RG2/S2L40/HER205	742Z021A28		
1	1		D513	D	1N4148/1SS133/1SS120	742Z001A21		
1	1		D514	D	1N4148/1SS133/1SS120	742Z001A21		
1	1		D515	D	HER108/EG01C/UF4007	742Z024A21		
1	1		D516	D	S3L40/HER305	742Z036A47		
1	1		D517	D	HER108/EG01C/UF4007	742Z024A21		
1	1		D518	D	SF34/S3L20U/ERC91-02	742Z035A38		
1	1		D519	D	SF34/S3L20U/ERC91-02	742Z035A38		
1	1		D520	D	HER103/UF4003/AL01Z/D1NL20U	742Z009A31		
1	1		D521	D	HER103/UF4003/AL01Z/D1NL20U	742Z009A31		
1	1		D522	D	1N4148/1SS133/1SS120	742Z001A21		
1	1		D523	D	EM01Z/D1N60/1N4003	742Z019A31		
1	1		D524	D	EM01Z/D1N60/1N4003	742Z019A31		
1	1		D525	ZD	MTZ-J27A/HZ24-3	742Z415A21		
1	1		D526	D	1N4148/1SS133/1SS120	742Z001A21		
1	1		D527	D	EG01/D1NL40/HER105	742Z020A31		
1	1		D528	ZD	MTZ-J10C/HZ11A2	742Z423A11		

**DWG. TITLE : ASSY-PWB-MAIN**

GROUP 10: HM903DT, 20: A902MT-v

GROUP		REV.	REF.NO	PART	DESCRIPTION	PART NO.	PRICE	REMARK
20	10							
1	1		D529	ZD	MTZ-J13C/HZ12B3	742Z417A21		
1	1		D531	D	1N4148/1SS133/1SS120	742Z001A21		
1	1		D532	D	D3S4M	742Z045A17		
1	1		D533	ZD	MTZ-J27A/HZ24-3	742Z415A21		
0	1		D534	SO-COPPER-WIRE		990Z001A11		
1	0		D534	ZD	MTZ-J27A/HZ24-3	742Z415A21		
0	1		D535	SO-COPPER-WIRE		990Z001A11		
1	0		D535	ZD	MTZ-J27A/HZ24-3	742Z415A21		
1	1		D801	D-CHIP	HSM123/DAN217/1PS226	742Z017A24		
1	1		D802	D-CHIP	HSM123/DAN217/1PS226	742Z017A24		
1	1		D803	D-CHIP	HSM123/DAN217/1PS226	742Z017A24		
1	1		D804	D-CHIP	HSM123/DAN217/1PS226	742Z017A24		
1	1		D805	ZD	MTZ-J4.7B/HZ5B1	742Z414A21		
1	1		D950	D	RBV-606/D5SBA60	742Z062A16		!
1	1		D951	D	YG912S6/SF8L60	742Z042A15		
1	1		D952	D	RB441Q/1SS165-03/SR104	742Z026A21		
1	1		D953	D	HER108/EG01C/UF4007	742Z024A21		
1	1		D954	D	EG01/D1NL40/HER105	742Z020A31		
1	1		D956	D	EG01/D1NL40/HER105	742Z020A31		
1	1		D957	D	EG01/D1NL40/HER105	742Z020A31		
1	1		D961	SO-COPPER-WIRE		990Z001A11		
1	1		D962	ZD	MTZ-J4.7B/HZ5B1	742Z414A21		
1	1		D963	D	1N4148/1SS133/1SS120	742Z001A21		
1	1		D964	D	S3L40	742Z036A10		
1	1		D965	D	HER108/EG01C/UF4007	742Z024A21		
1	1		D967	D	1N4148/1SS133/1SS120	742Z001A21		
1	1		D968	D	EM01Z/D1N60/1N4003	742Z019A31		
1	1		D969	D	S3L40/31DF4/HER305	742Z036A28		
1	1		D971	D	FML-G12S/D4L20U/SF6L20U	742Z011A15		
1	1		D972	D	FML-G12S/D4L20U/SF6L20U	742Z011A15		
1	1		D973	D	SF34/31DF2	742Z035A27		
1	1		D974	D	EG01/D1NL40/HER105	742Z020A31		
1	1		D976	D	RB441Q/1SS165-03/SR104	742Z026A21		
1	1		D977	ZD	MTZ-J5.1A/HZ5B3	742Z406A81		
1	1		D978	D	1N4148/1SS133/1SS120	742Z001A21		
1	1		IC301	IC	TMP86PP11AN	741Z626B10		
1	1		IC302	IC	M51951BSL/KIA7045P	741Z017A33		
1	1		IC303	IC	24C08	741Z018A20		
1	1		IC304	IC	MIU-231	741Z706A10		
1	1			SOCKET-IC	8305-42AT00/CLC3042-0101	448Z012A10		
1	1		IC350	IC	UPC1888FCT	741Z452A10		
1	1		IC351	IC	7812	741Z501A95		
1	1		IC352	IC-CHIP	358	741Z225A14		
1	1		IC401	IC	LA7840L	741Z414A10		
1	1		IC501	IC	MSPAD383	741Z707A10		
1	1		IC502	IC	SLA5070	741Z449A17		
1	1		IC503	IC	7805	741Z532A35		
1	1		IC801	IC	LA6510/TA8410AK	741Z217A20		
1	1		IC802	IC	LA6510/TA8410AK	741Z217A20		
1	1		IC950	IC	431	741Z212A53		
1	1		IC951	IC	STR-F6676	741Z525A17		
1	1		IC952	IC	MC34262P/MC33262P	741Z409A10		
1	1		IC953	IC	7812	741Z501A95		
1	1		K501	RELAY	F2AK12T/LKS321/DG12D1/SDT12LMR	781Z010A10		
1	1		K502	RELAY	F2AK12T/LKS321/DG12D1/SDT12LMR	781Z010A10		
1	1		K950	RELAY	OSA-SS-212DM5/DG12D2/ALA2PF12	781Z007A10		!
1	1		L301	COIL-CHOKE	22MH	751Z308A26		
1	1		L304	FERRITE-BEADS	ZBF503/EXCEL	750Z906A13		
1	1		L350	SO-COPPER-WIRE		990Z001A11		
1	1		L401	COIL-CHOKE	22MH	751Z308A26		
1	1		L402	COIL-CHOKE	22MH	751Z308A26		
1	1		L501	COIL-CHOKE	2100MH	751Z906A80		

**DWG. TITLE : ASSY-PWB-MAIN**

GROUP 10: HM903DT, 20: A902MT-v

GROUP		REV.	REF.NO	PART	DESCRIPTION	PART NO.	PRICE	REMARK
20	10							
1	1		L502	COIL-CHOKE	470MH	751Z308A46		
1	1		L503	COIL-H-LIN		754Z004A80		
1	1		L504	COIL-CHOKE	22MH	751Z619A66		
1	1		L505	SO-COPPER-WIRE		990Z001A11		
1	1		L506	SO-COPPER-WIRE		990Z001A11		
1	1		L507	COIL-H-LIN		754Z006A40		
1	1		L508	COIL-CHOKE	3R3MH	751Z309A13		
1	1		L509	COIL-CHOKE	470MH	751Z308A46		
1	1		L510	COIL-CHOKE	470MH	751Z308A46		
1	1		L511	FERRITE-BEADS	ZBF503/EXCEL	750Z906A13		
1	1		L513	FERRITE-BEADS	ZBF503/EXCEL	750Z906A13		
1	1		L514	FERRITE-BEADS	ZBF503/EXCEL	750Z906A13		
1	1		L950	FERRITE-BEADS	ZBF503/EXCEL	750Z906A13		
1	1		L951	FERRITE-BEADS	ZBF503/EXCEL	750Z906A13		
1	1		L952	FERRITE-BEADS	ZBF503/EXCEL	750Z906A13		
1	1		L953	SO-COPPER-WIRE		990Z001A11		
1	1		L954	COIL-CHOKE	100MH	751Z308A36		
1	1		L955	COIL-CHOKE	550MH	751Z905A10		
1	1		L956	FERRITE-BEADS	ZBF503/EXCEL	750Z906A13		
1	1		L957	FERRITE-BEADS	ZBF503/EXCEL	750Z906A13		
1	1		L958	COIL-CHOKE	22MH	751Z308A26		
1	1		L959	COIL-CHOKE	47MH	751Z619A16		
1	1		PC950	PHC	TLP421F(D4-GR)	743Z002A10		!
1	1		PR950	PTH	AC270V 4R5	782Z010A10		
1	1		Q350	TR-CHIP	BT1815/2SC2412/KTC3875/2PD601	740Z151A34		
1	1		Q351	TR-CHIP	KRC103/DTC124/RN1403/PDTC124	740Z654A34		
1	1		Q352	TR-CHIP	KRC103/DTC124/RN1403/PDTC124	740Z654A34		
1	1		Q353	TR-CHIP	BT1815/2SC2412/KTC3875/2PD601	740Z151A34		
1	1		Q501	TR-CHIP	BT1815/2SC2412/KTC3875/2PD601	740Z151A34		
1	1		Q503	TR	2SC5570	740Z167A15		
1	1		Q504	TR	2SK2962	740Z467A13		
1	1		Q505	TR-CHIP	KRC105S/DTC123JKA/RN1405	740Z665A14		
1	1		Q506	TR-CHIP	KRA103/DTA124/RN2403/PDTA124	740Z661A34		
1	1		Q507	TR-CHIP	BT1815/2SC2412/KTC3875/2PD601	740Z151A34		
1	1		Q508	TR-CHIP	BT1015/2SA1037/KTA1504/2PB709	740Z001A34		
1	1		Q509	TR-CHIP	KRC105S/DTC123JKA/RN1405	740Z665A14		
1	1		Q516	TR	2SC5248	740Z165A15		
1	1		Q517	TR	2SA1964	740Z009A15		
1	1		Q518	TR	BF422/HBF422	740Z163A23		
1	1		Q519	TR-CHIP	BT1015/2SA1037/KTA1504/2PB709	740Z001A34		
1	1		Q520	TR	2SC4620	740Z173A13		
1	1		Q521	TR	2SK2364/2SK2543/2SK2640-01MR	740Z464A15		
1	1		Q522	TR-CHIP	BT1815/2SC2412/KTC3875/2PD601	740Z151A34		
1	1		Q523	TR-CHIP	BT1015/2SA1037/KTA1504/2PB709	740Z001A34		
1	1		Q524	TR-CHIP	BT1015/2SA1037/KTA1504/2PB709	740Z001A34		
1	1		Q525	TR-CHIP	BT1015/2SA1037/KTA1504/2PB709	740Z001A34		
1	1		Q526	TR-CHIP	KRC103/DTC124/RN1403/PDTC124	740Z654A34		
1	1		Q527	TR-CHIP	RN1401/DTC143EKA/KRC101S	740Z667A24		
1	1		Q528	TR-CHIP	RN1401/DTC143EKA/KRC101S	740Z667A24		
1	1		Q529	TR-CHIP	RN1401/DTC143EKA/KRC101S	740Z667A24		
1	1		Q530	TR-CHIP	RN1401/DTC143EKA/KRC101S	740Z667A24		
1	1		Q531	TR-CHIP	RN1401/DTC143EKA/KRC101S	740Z667A24		
1	1		Q532	TR-CHIP	RN1401/DTC143EKA/KRC101S	740Z667A24		
1	1		Q533	TR	2SA821S	740Z003A13		
1	1		Q950	TR	2SK2364/2SK2543/2SK2640-01MR	740Z464A15		
1	1		Q951	TR	2SK2508/2SK2341	740Z451A25		
1	1		Q952	TR-CHIP	BT1815/2SC2412/KTC3875/2PD601	740Z151A34		
1	1		Q953	TR-CHIP	BT1015/2SA1037/KTA1504/2PB709	740Z001A34		
1	1		Q954	TR-CHIP	KRC105S/DTC123JKA/RN1405	740Z665A14		
1	1		R301	R-M-CHIP	1/10W 4R7K-J	613Z472C24		
1	1		R302	R-M-CHIP	1/10W 4R7K-J	613Z472C24		
1	1		R303	R-M-CHIP	1/10W 33-J	613Z330C24		

**DWG. TITLE : ASSY-PWB-MAIN**

GROUP 10: HM903DT, 20: A902MT-v

GROUP		REV.	REF.NO	PART	DESCRIPTION	PART NO.	PRICE	REMARK
20	10							
1	1		R304	R-M-CHIP	1/10W 33-J	613Z330C24		
1	1		R305	R-M-CHIP	1/10W 33-J	613Z330C24		
1	1		R306	R-M-CHIP	1/10W 1K-J	613Z102C24		
1	1		R307	R-C	1/4W 100-J	613Z101C11		
1	1		R308	R-M-CHIP	1/10W 33-J	613Z330C24		
1	1		R310	R-M-CHIP	1/10W 10K-J	613Z103C24		
1	1		R311	R-C	1/4W 10K-J	613Z103C11		
1	1		R312	R-M-CHIP	1/10W 1K-J	613Z102C24		
1	1		R313	R-M-CHIP	1/10W 33-J	613Z330C24		
1	1		R314	R-M-CHIP	1/10W 1K-J	613Z102C24		
1	1		R316	R-M-CHIP	1/10W 33-J	613Z330C24		
1	1		R317	R-M-CHIP	1/10W 4R7K-J	613Z472C24		
1	1		R319	R-C	1/4W 4R7K-J	613Z472C11		
1	1		R320	R-M-CHIP	1/10W 4R7K-J	613Z472C24		
1	1		R321	R-M-CHIP	1/10W 4R7K-J	613Z472C24		
1	1		R322	R-M-CHIP	1/10W 4R7K-J	613Z472C24		
1	1		R324	R-M-CHIP	1/10W 100-J	613Z101C24		
1	1		R325	R-M-CHIP	1/10W 100-J	613Z101C24		
1	1		R326	R-M-CHIP	1/10W 1K-J	613Z102C24		
1	1		R331	R-M-CHIP	1/10W 4R7K-J	613Z472C24		
1	1		R332	R-M-CHIP	1/10W 33-J	613Z330C24		
1	1		R333	R-M-CHIP	1/10W 33-J	613Z330C24		
1	1		R335	R-C	1/4W 1K-J	613Z102C11		
1	1		R336	R-M-CHIP	1/10W 1K-J	613Z102C24		
1	1		R350	R-M-CHIP	1/10W 1K-J	613Z102C24		
1	1		R351	R-M-CHIP	1/10W 1K-J	613Z102C24		
1	1		R352	R-M-CHIP	1/10W 1K-J	613Z102C24		
1	1		R353	R-M-CHIP	1/10W 100-J	613Z101C24		
1	1		R354	R-M-CHIP	1/10W 1R5K-J	613Z152C24		
1	1		R355	R-M-CHIP	1/10W 47K-F	613Z473C54		
1	1		R356	R-M-CHIP	1/10W 2R2K-F	613Z222C54		
1	1		R357	R-M-CHIP	1/10W 20K-J	613Z203C24		
1	1		R358	R-M-CHIP	1/10W 33K-F	613Z333C54		
1	1		R359	R-M-CHIP	1/10W 6R8K-J	613Z682C24		
1	1		R360	R-C	1/4W 10K-J	613Z103C11		
1	1		R361	R-M-CHIP	1/10W 33-J	613Z330C24		
1	1		R362	R-M-CHIP	1/10W 33-J	613Z330C24		
1	1		R363	R-M-CHIP	1/10W 22K-F	613Z223C54		
1	1		R364	R-M-CHIP	1/10W 10K-J	613Z103C24		
1	1		R365	R-M-CHIP	1/10W 10K-J	613Z103C24		
1	1		R366	R-M-CHIP	1/10W 27K-F	613Z273C54		
1	1		R367	R-M-CHIP	1/10W 20K-J	613Z203C24		
1	1		R371	R-M-CHIP	1/10W 2R2K-J	613Z222C24		
1	1		R372	R-M-CHIP	1/10W 1R2K-F	613Z122C54		
1	1		R373	R-M-CHIP	1/10W ZERO	613Z999B24		
1	1		R374	R-M-CHIP	1/10W 1R6K-F	613Z162C54		
1	1		R375	R-MB	1/4W 22K-F	615Z223B11		
1	1		R376	R-M-CHIP	1/10W 270K-F	613Z274C54		
1	1		R377	R-M-CHIP	1/10W 820K-F	613Z824C54		
1	1		R378	R-M-CHIP	1/10W 3R3K-F	613Z332C54		
1	1		R382	R-M-CHIP	1/10W 16K-F	613Z163C54		
1	1		R383	R-M-CHIP	1/10W 10K-F	613Z103C54		
1	1		R384	R-M-CHIP	1/10W 100-J	613Z101C24		
1	1		R385	R-M-CHIP	1/10W 10K-F	613Z103C54		
1	0		R387	R-M-CHIP	1/10W 4R7K-J	613Z472C24		
0	1		R388	R-M-CHIP	1/10W 4R7K-J	613Z472C24		
1	1		R389	R-M-CHIP	1/10W 12K-F	613Z123C54		!
1	1		R390	R-C	1/4W 22K-J	613Z223C11		
1	1		R391	SO-COPPER-WIRE		990Z001A11		
1	1		R393	R-M-CHIP	1/10W 100-J	613Z101C24		!
1	1		R401	R-MB	1W 1-J	612Z109C27		
1	1		R402	R-C	1/2W 560-J	613Z561D81		



**DWG. TITLE : ASSY-PWB-MAIN**

GROUP 10: HM903DT, 20: A902MT-v

GROUP		REV.	REF.NO	PART	DESCRIPTION	PART NO.	PRICE	REMARK
20	10							
1	1		R403	R-M-CHIP	1/10W 6R8K-F	613Z682C54		
1	1		R404	R-M-CHIP	1/10W 12K-F	613Z123C54		
1	1		R405	R-MB	1/4W 33K-F	615Z333B11		
1	1		R406	R-FUSE	1/4W 1R5-J	614Z159A61		
1	1		R407	R-M-CHIP	1/10W 8R2K-F	613Z822C54		
1	1		R409	R-M-CHIP	1/10W 1K-J	613Z102C24		
1	1		R410	R-M-CHIP	1/10W 1R8K-F	613Z182C54		
1	1		R411	R-MB	1/4W 8R2K-F	615Z822B11		
1	1		R501	R-C	1/4W 47K-J	613Z473C11		
1	1		R505	R-FUSE	1/4W 10-J	614Z100A61		
1	1		R506	R-MB	1/2W 22-J	612Z220A17		
1	1		R507	R-MB	2W 100-J	612Z101C37		
1	1		R508	R-C	1/2W 15-J	613Z150D81		
1	1		R509	R-CE	5W R82-K	616Z828A56		
1	1		R511	R-C	1/2W 15-J	613Z150D81		
1	1		R512	R-CE	5W 110-J	616Z111C16		
1	1		R513	R-FUSE	1/4W 10-J	614Z100A61		
1	1		R514	R-MB	3W 160-J	612Z161A47		
1	1		R515	R-C	1/4W 1K-J	613Z102C11		
1	1		R516	R-M-CHIP	1/10W 2K-J	613Z202C24		
1	1		R518	R-M-CHIP	1/10W 2K-J	613Z202C24		
1	1		R519	R-M-CHIP	1/10W 4R7K-J	613Z472C24		
1	1		R520	R-M-CHIP	1/10W 150-J	613Z151C24		
1	1		R521	R-M-CHIP	1/10W 4R7K-J	613Z472C24		
1	1		R522	R-C	1/4W 150K-J	613Z154C11		
1	1		R523	R-M-CHIP	1/10W 150-J	613Z151C24		
1	1		R524	R-M-CHIP	1/10W 4R7K-J	613Z472C24		
1	1		R525	R-C	1/4W 150K-J	613Z154C11		
1	1		R526	R-M-CHIP	1/10W 150-J	613Z151C24		
1	1		R527	R-M-CHIP	1/10W 4R7K-J	613Z472C24		
1	1		R528	R-C	1/4W 150K-J	613Z154C11		
1	1		R529	R-M-CHIP	1/10W 150-J	613Z151C24		
1	1		R530	R-M-CHIP	1/10W 4R7K-J	613Z472C24		
1	1		R531	R-C	1/4W 150K-J	613Z154C11		
1	1		R532	R-M-CHIP	1/10W 150-J	613Z151C24		
1	1		R533	R-M-CHIP	1/10W 4R7K-J	613Z472C24		
1	1		R534	R-C	1/4W 150K-J	613Z154C11		
1	1		R535	R-M-CHIP	1/10W 150-J	613Z151C24		
1	1		R536	R-C	1/2W 7R5K-J	613Z752D81		
1	1		R537	R-C	1/4W 150K-J	613Z154C11		
1	1		R538	R-C	1/4W 10-J	613Z100B11		
1	1		R539	R-C	1/4W 10-J	613Z100B11		
1	1		R540	R-C	1/4W 47-J	613Z470C11		
1	1		R541	R-C	1/4W 39K-J	613Z393C11		
1	1		R542	R-C	1/4W 1R8K-J	613Z182C11		
1	1		R543	R-M-CHIP	1/10W 1K-J	613Z102C24		
1	1		R544	R-C	1/4W 1K-J	613Z102C11		
1	1		R545	R-FUSE	1/4W 10-J	614Z100A61		
1	1		R546	R-C	1/4W 470K-J	613Z474C11		
1	1		R547	R-C	1/4W 3R3M-J	613Z335F11		
1	1		R548	R-C	1/4W 22K-J	613Z223C11		
1	1		R549	R-C	1/4W 1R2K-J	613Z122C11		
1	1		R550	R-M-CHIP	1/10W 47K-J	613Z473C24		
1	1		R551	R-C	1/2W 1K-J	613Z102D81		
1	1		R552	R-C	1/4W 180-J	613Z181C11		
1	1		R553	R-MB	2W R1-J	612Z108G37		
1	1		R554	R-CE	7W 18-J	616Z180A67		
1	1		R556	R-CE	5W 68-J	616Z680C17		
1	1		R557	R-MB	1/4W 6R8K-F	615Z682B11		!
1	1		R558	R-M-CHIP	1/10W 36K-F	613Z363C54		!
1	1		R559	R-FUSE	1/4W R22-K	614Z228B11		
1	1		R560	R-C	1/4W 100-J	613Z101C11		



**DWG. TITLE : ASSY-PWB-MAIN**

GROUP 10: HM903DT, 20: A902MT-v

GROUP		REV.	REF.NO	PART	DESCRIPTION	PART NO.	PRICE	REMARK
20	10							
1	1		R561	R-FUSE	1/4W 2R2-J	614Z229A61		
1	1		R562	R-FUSE	1/4W 10-J	614Z100A61		
1	1		R563	R-C	1/4W 33-J	613Z330C11		
1	1		R564	R-C	1/4W 4R7K-J	613Z472C11		
1	1		R565	R-M-CHIP	1/10W ZERO	613Z999B24		
1	1		R566	R-C	1/4W 820-J	613Z821C11		
1	1		R567	R-M-CHIP	1/10W 22K-J	613Z223C24		
1	1		R568	R-C	1/4W 5R6K-J	613Z562C11		
1	1		R569	R-C	1/4W 5R6K-J	613Z562C11		
1	1		R571	R-M-CHIP	1/10W 240K-F	613Z244C54		!
1	1		R572	R-M-CHIP	1/10W 120K-F	613Z124C54		!
1	1		R573	R-C	1/4W 68K-J	613Z683C11		
1	1		R574	R-M-CHIP	1/10W 10K-J	613Z103C24		
1	1		R575	R-M-CHIP	1/10W 100K-J	613Z104C24		
1	1		R576	R-M-CHIP	1/10W 4R7K-J	613Z472C24		
1	1		R577	R-M-CHIP	1/10W 2R2K-J	613Z222C24		
1	1		R578	R-M-CHIP	1/10W 4R7K-J	613Z472C24		
1	1		R579	R	1/2W 56K-J	619Z563C71		
1	1		R580	R-M-CHIP	1/10W 220-J	613Z221C24		
1	1		R581	R-M-CHIP	1/10W 10K-J	613Z103C24		
1	1		R5A7	R-MB	2W R15-J	612Z158C37		
1	1		R701	R-C	1/4W 1K-J	613Z102C11		
1	1		R702	R-C	1/4W 1K-J	613Z102C11		
1	1		R703	R-C	1/4W 1K-J	613Z102C11		
1	1		R704	R-C	1/4W 1K-J	613Z102C11		
1	1		R802	R-MB	2W 22-J	612Z220C37		
1	1		R803	R-C	1/4W 5R6-J	613Z569C11		
1	1		R804	R-M-CHIP	1/10W 10K-J	613Z103C24		
1	1		R805	R-M-CHIP	1/10W 10K-J	613Z103C24		
1	1		R806	R-M-CHIP	1/10W 10K-J	613Z103C24		
1	1		R807	R-C	1/4W 5R6-J	613Z569C11		
1	1		R808	R-M-CHIP	1/10W 10K-J	613Z103C24		
1	1		R810	R-MB	2W 22-J	612Z220C37		
1	1		R812	R-MB	2W 22-J	612Z220C37		
1	1		R813	R-C	1/4W 5R6-J	613Z569C11		
1	1		R814	R-M-CHIP	1/10W 10K-J	613Z103C24		
1	1		R815	R-M-CHIP	1/10W 10K-J	613Z103C24		
1	1		R816	R-M-CHIP	1/10W 10K-J	613Z103C24		
1	1		R817	R-C	1/4W 5R6-J	613Z569C11		
1	1		R818	R-M-CHIP	1/10W 10K-J	613Z103C24		
1	1		R820	R-MB	2W 22-J	612Z220C37		
1	1		R821	R-M-CHIP	1/10W 3R9K-F	613Z392C54		
1	1		R822	R-M-CHIP	1/10W 47K-F	613Z473C54		
1	1		R823	R-M-CHIP	1/10W 18K-F	613Z183C54		
1	1		R824	R-C	1/4W 1K-J	613Z102C11		
1	1		R950	R	1/4W 910K-F	619Z914A61		
1	1		R951	R	1/4W 910K-F	619Z914A61		
1	1		R952	R-M-CHIP	1/10W 16K-F	613Z163C54		
1	1		R953	R-M-CHIP	1/10W 22K-J	613Z223C24		
1	1		R954	R-FUSE	1/4W 27-J	614Z270A61		
1	1		R956	R-FUSE	1/4W 10-J	614Z100A61		
1	1		R957	R-FUSE	1/4W 10K-J	614Z103A61		
1	1		R958	R-FUSE	1/4W 1K-J	614Z102A61		
1	1		R960	R-MB	2W R22-J	612Z228C37		
1	1		R961	R	1/4W 1M-F	619Z105A61		
1	1		R962	R	1/4W 910K-F	619Z914A61		
1	1		R964	R-M-CHIP	1/10W 12K-F	613Z123C54		
1	1		R965	R	1/4W 820K-F	619Z824A61		
1	1		R966	R	1/4W 820K-F	619Z824A61		
1	1		R967	R-C	1/4W 1K-J	613Z102C11		
1	1		R968	R-MB	2W 120K-J	612Z124G37		
1	1		R969	R-MB	2W 100K-J	612Z104A37		

**DWG. TITLE : ASSY-PWB-MAIN**

GROUP 10: HM903DT, 20: A902MT-v

GROUP		REV.	REF.NO	PART	DESCRIPTION	PART NO.	PRICE	REMARK
20	10							
1	1		R970	R-CE	5W 68K-J	616Z683C17		
1	1		R971	R-MB	2W 12-J	612Z120C37		
1	1		R972	R-FUSE	1/4W 33-J	614Z330A61		
1	1		R974	R-C	1/4W 1R2K-J	613Z122C11		
1	1		R975	R-M-CHIP	1/10W 1K-J	613Z102C24		
1	1		R976	R-M-CHIP	1/10W 30K-F	613Z303C54		
1	1		R978	R-MB	2W R33-J	612Z338C37		
1	1		R979	R-C	1/4W 680-J	613Z681C11		
1	1		R981	R-C	1/4W 8R2K-J	613Z822C11		
1	1		R982	R-C	1/4W 130K-J	613Z134C11		
1	1		R983	R-C	1/4W 4R7K-J	613Z472C11		
1	1		R984	R-MB	2W 680-J	612Z681C37		
1	1		R985	R-MB	2W R22-J	612Z228C37		
1	1		R986	R-C	1/4W 1K-J	613Z102C11		
1	1		R987	R-FUSE	1/2W 100-J	614Z101A71		
1	1		R988	R-M-CHIP	1/10W 6R2K-F	613Z622C54		
1	1		R989	R-C	1/4W 10K-J	613Z103C11		
1	1		R990	R-C	1/4W 47K-J	613Z473C11		
1	1		R993	R-C	1/4W 2R2K-J	613Z222C11		
1	1		R994	R-FUSE	1/4W 15-J	614Z150A61		
3	3		R995	FERRITE-BEADS	ZBF503/EXCEL	750Z906A13		
1	1		R996	SO-COPPER-WIRE		990Z001A11		
1	1		R997	R-FUSE	1/4W 15-J	614Z150A61		
1	1		R998	R-FUSE	1/4W 15-J	614Z150A61		
1	1		R999	SO-COPPER-WIRE		990Z001A11		
1	1		R9A1	SO-COPPER-WIRE		990Z001A11		
1	1		R9A2	R-FUSE	1/4W 15-J	614Z150A61		
1	1		R9A3	R-MB	2W 56K-J	612Z563C37		
1	1		R9A4	R-MB	3W 22-J	612Z220C47		
1	1		R9A5	R-M-CHIP	1/8W 2R2K-J	613Z222C74		
1	1		R9A6	R-C	1/4W 10-J	613Z100C11		
1	1		R9A7	R-MB	2W 56K-J	612Z563C37		
1	1		R9A8	R-M-CHIP	1/8W 2R2K-J	613Z222C74		
1	1		R9B1	R-M-CHIP	1/10W 39K-J	613Z393C24		
1	1		R9B2	FUSE	251005/20N5000	283Z221A21		
1	1		R9B3	R	1/2W 4R7M-J	619Z475A71		
1	1		R9B4	R	1/2W 4R7M-J	619Z475A71		
1	1		R9B5	R-MB	1/4W 4R7K-F	615Z472B11		
1	1		R9B6	R-MB	1/4W 4R7K-F	615Z472B11		
1	1		R9B7	R-M-CHIP	1/10W 43K-J	613Z433C24		
1	1		R9B8	R-M-CHIP	1/10W 100-F	613Z101C54		
1	1		R9B9	R-M-CHIP	1/10W 330-J	613Z331C24		
1	1		R9C1	R-M-CHIP	1/10W 1R2K-J	613Z122C24		
1	1		SG501	NEON-LAMP	DSP-152M/YP-152N	789Z014A31		
1	1		T501	FBT		759Z012A10		!
1	1		T502	HDT		757Z001A20		
1	1		T503	SWT		756Z007A10		
1	1		T950	SWT		756Z016A20		!
1	1		T951	SWT		756Z005A30		
1	1		TH950	THERMISTOR	10	744Z001A28		!
1	1		VR501	VR	B-100K	620Z104A83		
1	1		VR502	VR	B-100K	620Z104A50		
1	1		VR951	VR	B-300	620Z301A60		
1	1		X301	X'TAL	12MHZ	780Z011A16		
1	1		AD	CONNECTOR	A3963WV2-5P-2,4NC	452Z052B10		!
1	1		B	CONNECTOR	A2501WV2-7P	452Z029F10		!
1	1		CL1	CONNECTOR	A2501WV2-5P	452Z029D10		!
1	1		CL2	CONNECTOR	A2501WV2-4P	452Z029C10		!
1	1		CT	CONNECTOR	A2501WV2-2P	452Z029A10		!
1	1		DG	CONNECTOR	A3963WV2-3P-2NC	452Z052A10		!
1	1		RS	CONNECTOR	A2501WV2-5P	452Z029D10		!
2	2		TH	GT-PIN	DIA2.36	452Z902A10		

**DWG. TITLE : ASSY-PWB-MAIN**

GROUP 10: HM903DT, 20: A902MT-v

GROUP		REV.	REF.NO	PART	DESCRIPTION	PART NO.	PRICE	REMARK
20	10							
1	1		MP	GT-PIN	DIA2.36	452Z902A10		
34	34			EYELET		679D022A20		
1	1			RADIATOR		595D313A10		
2	2			RADIATOR	OSH-2425/PR1724/790Z006-10	790Z006A10		
2	2			RADIATOR	23*41*1.2	790Z016A20		
1	1			RADIATOR	OSH-2054/2054-650-MP	790Z025A10		
1	1			PWB-MAIN		210R101-01		!

**DWG. TITLE : ASSY-PWB-STAND**

GROUP 10: HM903DT, A902MT-v

GROUP		REV.	REF.NO	PART	DESCRIPTION	PART NO.	PRICE	REMARK
20	10							
-	1		11	RADIATOR-B		590S146-01		
-	1		12	SHIELD-PLATE		590V110-01		
-	1		13	SHIELD-VIDEO-A		590S147-01		
-	1		14	SHIELD-USB		590T091-01		
-	4		17	SCREW	MP-SEMS-W3*10MC-S	630Z401B10		
-	2		18	SCREW	BTV3*8MC-S	631Z121B08		
-	1		22	LEAD-CONNECTOR		246T097-15		!
-	1		23	LEAD-CONNECTOR		246T097-07		!
-	1		24	LEAD-CONNECTOR		246T097-11		!
-	1		25	LEAD-CONNECTOR		246T097-14		!
-	1		27	CLAMPER	SHK-12	540Z080A01		!
-	1		28	CLAMPER	WS-A-1-01	540Z108A01		!
-	2		29	SPACER	TCBS-4-01	540Z042A03		
-	1		31	LEAD-WIRE		246V027-05		
-	1		C101	C-E	25V 100M-M	460Z101B43		
-	1		C102	C-C-CHIP	25V F-R1M-Z	411Z104B44		
-	1		C103	C-E	25V 100M-M	460Z101B43		
-	1		C104	C-C-CHIP	25V F-R1M-Z	411Z104B44		
-	1		C105	C-E	100V 1M-M	460Z109B83		
-	1		C106	C-C-CHIP	25V F-R1M-Z	411Z104B44		
-	1		C107	C-C-CHIP	25V F-R1M-Z	411Z104B44		
-	1		C108	C-E	25V 100M-M	460Z101B43		
-	1		C109	C-C-CHIP	50V CH-560P-J	410Z561B14		
-	1		C110	C-C-CHIP	50V CH-560P-J	410Z561B14		
-	1		C111	C-C-CHIP	50V CH-560P-J	410Z561B14		
-	1		C112	C-C-CHIP	50V CH-560P-J	410Z561B14		
-	1		C114	C-C-CHIP	50V CH-100P-J	410Z101B14		
-	1		C115	C-C-CHIP	50V CH-22P-J	410Z220B14		
-	1		C116	C-C-CHIP	50V CH-22P-J	410Z220B14		
-	1		C117	C-E	25V 100M-M	460Z101B43		
-	1		C118	C-E	25V 100M-M	460Z101B43		
-	1		C119	C-C-CHIP	25V F-R1M-Z	411Z104B44		
-	1		C121	C-C-CHIP	50V CH-22P-J	410Z220B14		
-	1		C122	C-C-CHIP	50V CH-22P-J	410Z220B14		
-	1		C123	C-C-CHIP	50V CH-22P-J	410Z220B14		
-	1		C127	C-C-CHIP	25V F-R1M-Z	411Z104B44		
-	1		C128	C-C-CHIP	25V F-R1M-Z	411Z104B44		
-	1		C129	C-C-CHIP	25V F-R1M-Z	411Z104B44		
-	1		C130	C-C-CHIP	25V F-R1M-Z	411Z104B44		
-	1		C131	C-E	25V 10M-M	460Z100G43		
-	1		C132	C-E	25V 100M-M	460Z101B43		
-	1		C133	C-E	25V 100M-M	460Z101B43		
-	1		C134	C-C-CHIP	25V F-R1M-Z	411Z104B44		
-	1		C135	C-C-CHIP	25V F-R1M-Z	411Z104B44		
-	1		C137	C-E	25V 100M-M	460Z101B43		
-	1		C138	C-C-CHIP	25V F-R1M-Z	411Z104B44		
-	1		C139	C-E	25V 100M-M	460Z101B43		
-	1		C140	C-E	25V 100M-M	460Z101B43		
-	1		C141	C-E	25V 100M-M	460Z101B43		
-	1		C142	C-E	100V 1M-M	460Z109B83		
-	1		C143	C-MF	50V R01M-J	420Z103A13		
-	1		C144	C-MF	50V R56M-J	420Z564A13		
-	1		C145	C-E-NP	100V 1M-M	472Z109F83		
-	1		C146	C-C-CHIP	25V F-R1M-Z	411Z104B44		
-	1		C147	C-C-CHIP	50V CH-100P-J	410Z101B14		
-	1		C148	C-E	100V 2R2M-M	460Z229B83		
-	1		C149	C-E	100V 2R2M-M	460Z229B83		
-	1		C151	C-C-CHIP	25V F-R1M-Z	411Z104B44		
-	1		C152	C-C-CHIP	25V F-R1M-Z	411Z104B44		
-	1		C153	C-E	16V 100M-M	465Z101C33		
-	1		C1B2	C-E	25V 47M-M	460Z470B43		
-	1		C1B4	C-E	25V 47M-M	460Z470B43		

**DWG. TITLE : ASSY-PWB-STAND**

GROUP 10: HM903DT, A902MT-v

GROUP		REV.	REF.NO	PART	DESCRIPTION	PART NO.	PRICE	REMARK
20	10							
-	1		C1G2	C-E	25V 47M-M	460Z470B43		
-	1		C1G4	C-E	25V 47M-M	460Z470B43		
-	1		C1R2	C-E	25V 47M-M	460Z470B43		
-	1		C1R4	C-E	25V 47M-M	460Z470B43		
-	1		C201	C-C-CHIP	50V B-4700P-K	411Z472B14		
-	1		C202	C-C-CHIP	25V F-R1M-Z	411Z104B44		
-	1		C203	C-E	100V 1M-M	460Z109B83		
-	1		C204	C-C-CHIP	25V F-R1M-Z	411Z104B44		
-	1		C205	C-E	25V 100M-M	460Z101B43		
-	1		C206	C-C-CHIP	25V F-R1M-Z	411Z104B44		
-	1		C207	C-E	25V 100M-M	470Z101T43		
-	1		C208	C-E	25V 100M-M	460Z101B43		
-	1		C209	C-C-CHIP	25V F-R1M-Z	411Z104B44		
-	1		C210	C-C-CHIP	25V F-R1M-Z	411Z104B44		
-	1		C211	C-E	25V 100M-M	460Z101B43		
-	1		C212	C-C-CHIP	25V F-R1M-Z	411Z104B44		
-	1		C213	C-E	25V 100M-M	460Z101B43		
-	1		C214	C-E	25V 100M-M	460Z101B43		
-	1		C215	C-C-CHIP	25V F-R1M-Z	411Z104B44		
-	1		C216	C-E	25V 100M-M	470Z101T43		
-	1		C217	C-C-CHIP	25V F-R1M-Z	411Z104B44		
-	1		C218	C-C	500V SL-68P-J	410Z680B43		
-	1		C219	C-C-CHIP	25V F-R1M-Z	411Z104B44		
-	1		C220	C-C-CHIP	50V CH-220P-J	410Z221B14		
-	1		C221	C-E	25V 100M-M	470Z101T43		
-	1		C222	C-C-CHIP	25V F-R1M-Z	411Z104B44		
-	1		C224	C-C-CHIP	25V F-R1M-Z	411Z104B44		
-	1		C225	C-C-CHIP	25V F-R1M-Z	411Z104B44		
-	1		C226	C-E	25V 100M-M	470Z101T43		
-	1		C227	C-E	100V 220M-M	470Z221G87		
-	1		C228	C-C	500V E-R01M-P/Z	411Z103A07		
-	1		C229	C-C	500V E-R01M-P/Z	411Z103A07		
-	1		C230	C-E	100V 10M-M	470Z100G83		
-	1		C231	C-C	500V E-R01M-P/Z	411Z103A07		
-	1		C232	C-E	100V 47M-M	470Z470G83		
-	1		C233	C-C	2KV B-1000P-K	413Z102B43		
-	1		C234	C-C	2KV B-3300P-K	413Z332A46		
-	1		C235	C-C-CHIP	25V F-R1M-Z	411Z104B44		
-	1		C236	C-E	25V 100M-M	470Z101T43		
-	1		C237	C-E	25V 100M-M	470Z101T43		
-	1		C238	C-C-CHIP	25V F-R1M-Z	411Z104B44		
-	1		C239	C-E	100V 1M-M	470Z109T83		
-	1		C241	C-C	500V E-R01M-P/Z	411Z103A07		
-	1		C242	C-C-CHIP	25V F-R1M-Z	411Z104B44		
-	1		C243	C-C-CHIP	25V F-R1M-Z	411Z104B44		
-	1		C244	C-C-CHIP	25V F-R1M-Z	411Z104B44		
-	1		C245	C-C-CHIP	25V F-R1M-Z	411Z104B44		
-	1		C246	C-C-CHIP	25V F-R1M-Z	411Z104B44		
-	1		C247	C-C-CHIP	25V F-R1M-Z	411Z104B44		
-	1		C248	C-C-CHIP	25V F-R1M-Z	411Z104B44		
-	1		C249	C-C-CHIP	25V F-R1M-Z	411Z104B44		
-	1		C250	C-C-CHIP	25V F-R1M-Z	411Z104B44		
-	1		C251	C-E-NP	25V 10M-M	472Z100E43		
-	1		C252	C-E-NP	25V 10M-M	472Z100E43		
-	1		C253	C-C-CHIP	25V F-R1M-Z	411Z104B44		
-	1		C254	C-C-CHIP	25V F-R1M-Z	411Z104B44		
-	1		C255	C-E-NP	25V 10M-M	472Z100E43		
-	1		C256	C-E-NP	25V 10M-M	472Z100E43		
-	1		C257	C-C-CHIP	25V F-R1M-Z	411Z104B44		
-	1		C258	C-C-CHIP	25V F-R1M-Z	411Z104B44		
-	1		C259	C-C-CHIP	25V F-R1M-Z	411Z104B44		
-	1		C261	C-C-CHIP	25V F-R1M-Z	411Z104B44		

**DWG. TITLE : ASSY-PWB-STAND**

GROUP 10: HM903DT, A902MT-v

GROUP		REV.	REF.NO	PART	DESCRIPTION	PART NO.	PRICE	REMARK
20	10							
-	1		C262	C-C-CHIP	25V F-R1M-Z	411Z104B44		
-	1		C263	C-C-CHIP	25V F-R1M-Z	411Z104B44		
-	1		C264	C-C	500V E-R01M-P/Z	411Z103A07		
-	1		C265	C-E	25V 100M-M	470Z101T43		
-	1		C266	C-E	25V 100M-M	470Z101T43		
-	1		C267	C-C	500V E-R01M-P/Z	411Z103A07		
-	1		C271	C-C-CHIP	25V F-R1M-Z	411Z104B44		
-	1		C272	C-C-CHIP	50V B-220P-K	411Z222B14		
-	1		C273	C-C	1KV E-R01M-Z	413Z103A38		
-	1		C274	C-C-CHIP	25V F-R1M-Z	411Z104B44		
-	1		C2B1	C-E-NP	50V 3R3M-M	472Z339F63		
-	1		C2B3	C-C-CHIP	100/200V CH-150P-J	410Z151A54		
-	1		C2B4	C-E-NP	100V 1M-M	472Z109F83		
-	1		C2B5	C-C-CHIP	25V F-R1M-Z	411Z104B44		
-	1		C2B6	C-E	100V R22M-M	470Z228N83		
-	1		C2G1	C-E-NP	50V 3R3M-M	472Z339F63		
-	1		C2G3	C-C-CHIP	100/200V CH-150P-J	410Z151A54		
-	1		C2G4	C-E-NP	100V 1M-M	472Z109F83		
-	1		C2G5	C-C-CHIP	25V F-R1M-Z	411Z104B44		
-	1		C2G6	C-E	100V R22M-M	470Z228N83		
-	1		C2R1	C-E-NP	50V 3R3M-M	472Z339F63		
-	1		C2R3	C-C-CHIP	100/200V CH-150P-J	410Z151A54		
-	1		C2R4	C-E-NP	100V 1M-M	472Z109F83		
-	1		C2R5	C-C-CHIP	25V F-R1M-Z	411Z104B44		
-	1		C2R6	C-E	100V R22M-M	470Z228N83		
-	1		C602	C-E	25V 100M-M	470Z101T43		
-	1		C613	C-E	100V 1M-M	460Z109B83		
-	1		C615	C-E-NP	100V 1M-M	462Z109B83		
-	1		C616	C-E-NP	100V 1M-M	462Z109B83		
-	1		C619	C-C-CHIP	25V F-R1M-Z	411Z104B44		
-	1		C623	C-C-CHIP	25V F-R1M-Z	411Z104B44		
-	1		C624	C-E	100V 1M-M	470Z109T83		
-	1		C625	C-E	100V 1M-M	470Z109T83		
-	1		C626	C-E	50V 22M-M	470Z220T63		
-	1		C701	C-E	25V 220M-M	470Z221T43		
-	1		C702	C-E	25V 220M-M	470Z221T43		
-	1		C703	C-E	25V 220M-M	470Z221T43		
-	1		C704	C-E	25V 220M-M	470Z221T43		
-	1		C705	C-E	25V 100M-M	460Z101B43		
-	1		C706	C-C-CHIP	50V CH-22P-J	410Z220B14		
-	1		C707	C-C-CHIP	50V CH-22P-J	410Z220B14		
-	1		C708	C-E	50V 3R3M-M	460Z339B63		
-	1		C709	C-E	25V 100M-M	460Z101B43		
-	1		C710	C-E	100V 1M-M	470Z109T83		
-	1		C711	C-C-CHIP	25V F-R1M-Z	411Z104B44		
-	1		C712	C-C-CHIP	25V F-R1M-Z	411Z104B44		
-	1		C713	C-C-CHIP	25V F-R1M-Z	411Z104B44		
-	1		C901	C-PP	AC250/275VR47M-M	510Z014A16		!
-	1		C905	C-C	2KV B-220P-K	413Z221B43		
-	1		C906	C-C	2KV B-220P-K	413Z221B43		
-	1		C907	C-E	400V 68M-M	467Z011A10		!
-	1		C909	C-E	50V 33M-M	460Z330B63		
-	1		C910	C-C	2KV SL-47P-J	414Z470A28		
-	1		C911	C-C-CHIP	50V CH-470P-J	410Z471B14		
-	1		C912	C-C-CHIP	50V F-R01M-Z	411Z103B24		
-	1		C913	C-C	AC250V 2200P-M	510Z012A16		!
-	1		C920	C-C-CHIP	25V F-R1M-Z	411Z104B44		
-	1		C921	C-C	2KV B-220P-K	413Z221B43		
-	1		C922	C-C	2KV B-220P-K	413Z221B43		
-	1		C923	C-E	25V 820M-M	470Z821S47		
-	1		C924	C-C-CHIP	25V F-R1M-Z	411Z104B44		
-	1		C925	C-E	25V 100M-M	460Z101B43		

**DWG. TITLE : ASSY-PWB-STAND**

GROUP 10: HM903DT, A902MT-v

GROUP		REV.	REF.NO	PART	DESCRIPTION	PART NO.	PRICE	REMARK
20	10							
-	1		C926	C-C-CHIP	25V F-R1M-Z	411Z104B44		
-	1		C928	C-E	25V 820M-M	470Z821S47		
-	1		C929	C-MF	50/100V R1M-J	420Z104B83		
-	1		C930	C-C-CHIP	25V F-R1M-Z	411Z104B44		
-	1		C931	C-E	25V 100M-M	460Z101B43		
-	1		C932	C-C-CHIP	25V F-R1M-Z	411Z104B44		
-	1		C933	C-E	25V 22M-M	460Z220G43		
-	1		C934	C-MF	50V R22M-J	420Z224A13		
-	1		CN203	SOCKET-CRT	ISDW02S-L	449Z005A10		!
-	1		D101	D-CHIP	HSM123/DAN217/1PS226	742Z017A24		
-	1		D102	D-CHIP	HSM123/DAN217/1PS226	742Z017A24		
-	1		D103	D-CHIP	HSM123/DAN217/1PS226	742Z017A24		
-	1		D104	D-CHIP	HSM123/DAN217/1PS226	742Z017A24		
-	1		D105	D-CHIP	HSM123/DAN217/1PS226	742Z017A24		
-	1		D106	D-CHIP	HSM123/DAN217/1PS226	742Z017A24		
-	1		D107	D-CHIP	HSM123/DAN217/1PS226	742Z017A24		
-	1		D108	D-CHIP	HSM123/DAN217/1PS226	742Z017A24		
-	1		D109	D	1N4148/1SS133/1SS120	742Z001A21		
-	1		D112	D	1N4148/1SS133/1SS120	742Z001A21		
-	1		D150	LED	TLYG116	262Z018A40		
-	1		D1B1	D-CHIP	HSM123/DAN217/1PS226	742Z017A24		
-	1		D1B2	D-CHIP	HSM123/DAN217/1PS226	742Z017A24		
-	1		D1B3	D-CHIP	HSM123/DAN217/1PS226	742Z017A24		
-	1		D1B4	D-CHIP	HSM123/DAN217/1PS226	742Z017A24		
-	1		D1G1	D-CHIP	HSM123/DAN217/1PS226	742Z017A24		
-	1		D1G2	D-CHIP	HSM123/DAN217/1PS226	742Z017A24		
-	1		D1G3	D-CHIP	HSM123/DAN217/1PS226	742Z017A24		
-	1		D1G4	D-CHIP	HSM123/DAN217/1PS226	742Z017A24		
-	1		D1R1	D-CHIP	HSM123/DAN217/1PS226	742Z017A24		
-	1		D1R2	D-CHIP	HSM123/DAN217/1PS226	742Z017A24		
-	1		D1R3	D-CHIP	HSM123/DAN217/1PS226	742Z017A24		
-	1		D1R4	D-CHIP	HSM123/DAN217/1PS226	742Z017A24		
-	1		D201	D	1N4148/1SS133/1SS120	742Z001A21		
-	1		D202	D	1N4148/1SS133/1SS120	742Z001A21		
-	1		D203	ZD	MTZ-J4.7B/HZ5B1	742Z414A21		
-	1		D2B3	D-CHIP	1SS376/HSU83	742Z039A24		
-	1		D2G3	D-CHIP	1SS376/HSU83	742Z039A24		
-	1		D2R3	D-CHIP	1SS376/HSU83	742Z039A24		
-	1		D701	D-CHIP	HSM123/DAN217/1PS226	742Z017A24		
-	1		D901	D	S1VB60/KBP06ML-6836	742Z056A16		!
-	1		D906	D	EG01/D1NL40/HER105	742Z020A31		
-	1		D908	D-CHIP	HSM123/DAN217/1PS226	742Z017A24		
-	1		D920	D	EM01Z/D1N60/1N4003	742Z019A31		
-	1		D921	D	SF5LC20U/FML-12S	742Z057A15		!
-	1		D922	D	SF10SC9/YG802C09R/FCH10A09	742Z058A15		
-	1		D923	D	HER108/EG01C/UF4007	742Z024A21		
-	1		D924	ZD	P6KE120/Z2120U	742Z420A11		
-	1		F901	FUSE	6.3A	283Z224A10		!
-	1		FC901	FUSE-CLIP	5.2+/-0.15*20-0.5MM	442Z002A13		
-	1		FC902	FUSE-CLIP	5.2+/-0.15*20-0.5MM	442Z002A13		
-	1		IC101	IC	BA7078S	741Z453A10		
-	1		IC102	IC-CHIP	24C21	741Z806A24		
-	1		IC103	IC-CHIP	24C21	741Z806A24		
-	1		IC104	IC	TMP47C241N	741Z620B10		
-	1		IC105	IC-CHIP	74LS157	741Z060A14		
-	1		IC201	IC	CXA2153S	741Z451A10		
-	1		IC202	IC	LM2412T	741Z440A17		
-	1		IC203	IC	M35047-057SP/063SP	741Z059A30		
-	1		IC204	IC	LM2480NA	741Z435A10		
-	1		IC205	IC	M62334P	741Z061A10		
-	1		IC206	IC	LA6510	741Z217A10		
-	1		IC207	IC	LA6510	741Z217A10		

**DWG. TITLE : ASSY-PWB-STAND**

GROUP 10: HM903DT, A902MT-v

GROUP		REV.	REF.NO	PART	DESCRIPTION	PART NO.	PRICE	REMARK
20	10							
-	1		IC208	IC	7805	741Z532A35		
-	1		IC601	IC	AN7522	741Z431A10		
-	1		IC701	IC	ISP1122	741Z062A10		
-	1		IC702	IC	PCF8582C	741Z063A10		
-	1		IC901	IC	STR-G6551	741Z528A17		
-	1		IC921	IC	431	741Z212A53		
-	1		K901	RELAY	F2AK05T/LKS329/DG5D1/SDT05LMR	781Z010A20		!
-	1		L102	R-M-CHIP	1/10W ZERO	613Z999B24		
-	1		L103	R-M-CHIP	1/10W ZERO	613Z999B24		
-	1		L104	R-M-CHIP	1/10W ZERO	613Z999B24		
-	1		L105	R-M-CHIP	1/10W ZERO	613Z999B24		
-	1		L106	R-M-CHIP	1/10W ZERO	613Z999B24		
-	1		L107	R-M-CHIP	1/10W ZERO	613Z999B24		
-	1		L108	R-M-CHIP	1/10W ZERO	613Z999B24		
-	1		L109	R-M-CHIP	1/10W ZERO	613Z999B24		
-	1		L110	COIL-CHOKE	22MH	750Z301A31		
-	1		L150	SO-COPPER-WIRE		990Z001A11		
-	1		L1B1	R-M-CHIP	1/8W ZERO	613Z999B34		
-	1		L1B2	R-M-CHIP	1/8W ZERO	613Z999B34		
-	1		L1G1	R-M-CHIP	1/8W ZERO	613Z999B34		
-	1		L1G2	R-M-CHIP	1/8W ZERO	613Z999B34		
-	1		L1R1	R-M-CHIP	1/8W ZERO	613Z999B34		
-	1		L1R2	R-M-CHIP	1/8W ZERO	613Z999B34		
-	1		L202	COIL-CHOKE	22MH	750Z602A11		
-	1		L203	COIL-CHOKE	22MH	751Z308A26		
-	1		L204	FILTER-CHIP	STC104B	752Z020A24		
-	1		L207	SO-COPPER-WIRE		990Z001A11		
-	1		L208	SO-COPPER-WIRE		990Z001A11		
-	1		L213	FILTER-CHIP	STC104B	752Z020A24		
-	1		L216	FERRITE-BEADS	ZBF503/EXCEL	750Z906A13		
-	1		L2B1	R-M-CHIP	1/10W ZERO	613Z999B24		
-	1		L2B3	COIL-CHOKE	R22MH	750Z003A11		
-	1		L2B4	R-M-CHIP	1/10W ZERO	613Z999B24		
-	1		L2G1	R-M-CHIP	1/10W ZERO	613Z999B24		
-	1		L2G3	COIL-CHOKE	R22MH	750Z003A11		
-	1		L2G4	R-M-CHIP	1/10W ZERO	613Z999B24		
-	1		L2R1	R-M-CHIP	1/10W ZERO	613Z999B24		
-	1		L2R3	COIL-CHOKE	R22MH	750Z003A11		
-	1		L2R4	R-M-CHIP	1/10W ZERO	613Z999B24		
-	1		L601	FILTER-CHIP	STC222B	752Z020A14		
-	1		L602	FILTER-CHIP	STC222B	752Z020A14		
-	1		L603	FILTER-CHIP	STC222B	752Z020A14		
-	1		L604	FILTER-CHIP	STC222B	752Z020A14		
-	1		L605	FILTER-CHIP	STC222B	752Z020A14		
-	1		L606	FILTER-CHIP	STC222B	752Z020A14		
-	1		L607	SO-COPPER-WIRE		990Z001A11		
-	1		L701	FERRITE-CHIP	BLM21PG221SN1	750Z901A34		
-	1		L702	FERRITE-CHIP	BLM21PG221SN1	750Z901A34		
-	1		L703	FERRITE-CHIP	BLM21PG221SN1	750Z901A34		
-	1		L704	FERRITE-CHIP	BLM21PG221SN1	750Z901A34		
-	1		L705	FERRITE-CHIP	BLM21PG221SN1	750Z901A34		
-	1		L706	FERRITE-CHIP	BLM21PG221SN1	750Z901A34		
-	1		L707	FERRITE-CHIP	BLM21PG221SN1	750Z901A34		
-	1		L708	FERRITE-CHIP	BLM21PG221SN1	750Z901A34		
-	1		L709	FERRITE-CHIP	BLM21PG221SN1	750Z901A34		
-	1		L710	FERRITE-CHIP	BLM21BB221SN1	750Z901A54		
-	1		L711	FERRITE-CHIP	BLM21BB221SN1	750Z901A54		
-	1		L712	FERRITE-CHIP	BLM21BB221SN1	750Z901A54		
-	1		L713	FERRITE-CHIP	BLM21BB221SN1	750Z901A54		
-	1		L714	FERRITE-CHIP	BLM21BB221SN1	750Z901A54		
-	1		L715	FERRITE-CHIP	BLM21PG221SN1	750Z901A34		
-	1		L716	FERRITE-CHIP	BLM21PG221SN1	750Z901A34		



**DWG. TITLE : ASSY-PWB-STAND**

GROUP 10: HM903DT, A902MT-v

GROUP		REV.	REF.NO	PART	DESCRIPTION	PART NO.	PRICE	REMARK
20	10							
-	1		L717	FERRITE-CHIP	BLM21PG221SN1	750Z901A34		
-	1		L718	FILTER-CHIP	STC222B	752Z020A14		
-	1		L719	FILTER-CHIP	STC222B	752Z020A14		
-	1		L720	FERRITE-CHIP	BLM21PG221SN1	750Z901A34		
-	1		L721	FERRITE-CHIP	BLM21BB221SN1	750Z901A54		
-	1		L722	FERRITE-CHIP	BLM21BB221SN1	750Z901A54		
-	1		L723	FERRITE-CHIP	BLM21BB221SN1	750Z901A54		
-	1		L724	FERRITE-CHIP	BLM21BB221SN1	750Z901A54		
-	1		L725	FERRITE-CHIP	BLM21BB221SN1	750Z901A54		
-	1		L901	LINE-FILTER	SS28H/753Z019	753Z019A10		!
-	1		L902	LINE-FILTER	SS28V/753Z018	753Z018A10		!
-	1		L903	SO-COPPER-WIRE		990Z001A11		
-	1		L920	COIL-CHOKE	10MH	751Z619A26		
-	1		L921	COIL-CHOKE	10MH	751Z619A26		
-	1		PC901	PHC	TLP421F(D4-GR)	743Z002A10		!
-	1		Q101	TR-CHIP	2SC2412K	740Z151A14		
-	1		Q102	TR-CHIP	2SC2412K	740Z151A14		
-	1		Q150	TR-CHIP	KRA103/DTA124/RN2403/PDTA124	740Z661A34		
-	1		Q151	TR-CHIP	KRA103/DTA124/RN2403/PDTA124	740Z661A34		
-	1		Q152	TR-CHIP	KRC103/DTC124/RN1403/PDTC124	740Z654A34		
-	1		Q1B1	TR-CHIP	2SC3082K	740Z152A14		
-	1		Q1B2	TR-CHIP	2SC3082K	740Z152A14		
-	1		Q1G1	TR-CHIP	2SC3082K	740Z152A14		
-	1		Q1G2	TR-CHIP	2SC3082K	740Z152A14		
-	1		Q1R1	TR-CHIP	2SC3082K	740Z152A14		
-	1		Q1R2	TR-CHIP	2SC3082K	740Z152A14		
-	1		Q201	TR-CHIP	BT1815/2SC2412/KTC3875/2PD601	740Z151A34		
-	1		Q202	TR-CHIP	BT1815/2SC2412/KTC3875/2PD601	740Z151A34		
-	1		Q203	TR-CHIP	KRC103/DTC124/RN1403/PDTC124	740Z654A34		
-	1		Q204	TR-CHIP	BT1815/2SC2412/KTC3875/2PD601	740Z151A34		
-	1		Q602	TR-CHIP	BT1815/2SC2412/KTC3875/2PD601	740Z151A34		
-	1		Q920	TR	2SC5395/2SC1740S/2SC945/KTC945	740Z160A23		
-	1		Q921	TR	2SA1020	260A020B10		
-	1		Q922	TR-CHIP	KRC103/DTC124/RN1403/PDTC124	740Z654A34		
-	1		R101	R-M-CHIP	1/10W 4R7K-J	613Z472C24		
-	1		R102	R-M-CHIP	1/10W 4R7K-J	613Z472C24		
-	1		R103	R-M-CHIP	1/10W 4R7K-J	613Z472C24		
-	1		R104	R-M-CHIP	1/10W 4R7K-J	613Z472C24		
-	1		R107	R-M-CHIP	1/10W 33-J	613Z330C24		
-	1		R108	R-C	1/4W 33-J	613Z330C11		
-	1		R109	R-C	1/4W 33-J	613Z330C11		
-	1		R110	R-M-CHIP	1/10W 33-J	613Z330C24		
-	1		R112	R-M-CHIP	1/10W 4R7K-J	613Z472C24		
-	1		R113	R-M-CHIP	1/10W 4R7K-J	613Z472C24		
-	1		R114	R-M-CHIP	1/10W 1K-J	613Z102C24		
-	1		R115	R-C	1/4W 680-J	613Z681C11		
-	1		R119	R-M-CHIP	1/10W 1K-J	613Z102C24		
-	1		R120	SO-COPPER-WIRE		990Z001A11		
-	1		R121	R-M-CHIP	1/10W ZERO	613Z999B24		
-	1		R122	SO-COPPER-WIRE		990Z001A11		
-	1		R123	R-M-CHIP	1/10W ZERO	613Z999B24		
-	1		R124	R-C	1/4W 1K-J	613Z102C11		
-	1		R126	R-M-CHIP	1/10W 4R7K-J	613Z472C24		
-	1		R127	R-M-CHIP	1/10W 4R7K-J	613Z472C24		
-	1		R128	R-M-CHIP	1/10W 33-J	613Z330C24		
-	1		R129	R-M-CHIP	1/10W 33-J	613Z330C24		
-	1		R130	R-M-CHIP	1/10W 1K-J	613Z102C24		
-	1		R131	R-M-CHIP	1/10W 4R7K-J	613Z472C24		
-	1		R132	R-M-CHIP	1/10W 33-J	613Z330C24		
-	1		R133	R-M-CHIP	1/10W 33-J	613Z330C24		
-	1		R134	R-M-CHIP	1/10W 33-J	613Z330C24		
-	1		R135	R-M-CHIP	1/10W 1K-J	613Z102C24		

**DWG. TITLE : ASSY-PWB-STAND**

GROUP 10: HM903DT, A902MT-v

GROUP		REV.	REF.NO	PART	DESCRIPTION	PART NO.	PRICE	REMARK
20	10							
-	1		R136	R-C	1/4W 4R7K-J	613Z472C11		
-	1		R137	R-C	1/4W 1K-J	613Z102C11		
-	1		R138	R-M-CHIP	1/10W 4R7K-J	613Z472C24		
-	1		R139	R-M-CHIP	1/10W 1K-J	613Z102C24		
-	1		R140	R-M-CHIP	1/10W 1K-J	613Z102C24		
-	1		R141	R-M-CHIP	1/10W 1K-J	613Z102C24		
-	1		R142	R-M-CHIP	1/10W 100-J	613Z101C24		
-	1		R143	R-M-CHIP	1/10W 100-J	613Z101C24		
-	1		R144	R-M-CHIP	1/10W 3R9K-J	613Z392C24		
-	1		R145	R-M-CHIP	1/10W 3R3K-J	613Z332C24		
-	1		R146	R-M-CHIP	1/10W 4R7K-J	613Z472C24		
-	1		R147	R-M-CHIP	1/10W 4R7K-J	613Z472C24		
-	1		R148	R-M-CHIP	1/10W 4R7K-J	613Z472C24		
-	1		R150	R-M-CHIP	1/10W ZERO	613Z999B24		
-	1		R151	R-M-CHIP	1/10W 10K-J	613Z103C24		
-	1		R152	R-M-CHIP	1/10W ZERO	613Z999B24		
-	1		R153	R-M-CHIP	1/10W 39K-J	613Z393C24		
-	1		R154	R-M-CHIP	1/10W 15K-J	613Z153C24		
-	1		R155	R-M-CHIP	1/10W 6R8K-J	613Z682C24		
-	1		R156	R-M-CHIP	1/10W 10K-J	613Z103C24		
-	1		R157	R-M-CHIP	1/10W 10K-J	613Z103C24		
-	1		R158	R-C	1/4W 180-J	613Z181C11		
-	1		R159	R-C	1/4W 180-J	613Z181C11		
-	1		R160	R-MB	1/4W 100K-F	615Z104B11		
-	1		R161	R-M-CHIP	1/10W 10K-J	613Z103C24		
-	1		R162	R-M-CHIP	1/10W 1K-J	613Z102C24		
-	1		R164	R-C	1/4W 180-J	613Z181C11		
-	1		R165	R-M-CHIP	1/10W 10K-J	613Z103C24		
-	1		R166	R-C	1/4W 180-J	613Z181C11		
-	1		R171	R-M-CHIP	1/10W 39K-J	613Z393C24		
-	1		R172	R-M-CHIP	1/10W 20K-J	613Z203C24		
-	1		R173	R-M-CHIP	1/10W 10K-J	613Z103C24		
-	1		R174	R-M-CHIP	1/10W 5R1K-J	613Z512C24		
-	1		R175	R-M-CHIP	1/10W 12K-J	613Z123C24		
-	1		R176	R-M-CHIP	1/10W 5R1K-J	613Z512C24		
-	1		R1B1	R-M-CHIP	1/10W 75-F	613Z750C54		
-	1		R1B2	R-M-CHIP	1/10W 75-F	613Z750C54		
-	1		R1B3	R-M-CHIP	1/10W 150-J	613Z151C24		
-	1		R1B4	R-M-CHIP	1/10W 68-J	613Z680C24		
-	1		R1B5	R-M-CHIP	1/10W 15K-J	613Z153C24		
-	1		R1B6	R-M-CHIP	1/10W 39K-J	613Z393C24		
-	1		R1B7	R-M-CHIP	1/10W 100-J	613Z101C24		
-	1		R1B8	R-M-CHIP	1/10W 15K-J	613Z153C24		
-	1		R1B9	R-M-CHIP	1/10W 39K-J	613Z393C24		
-	1		R1BA	R-M-CHIP	1/10W 100-J	613Z101C24		
-	1		R1G1	R-M-CHIP	1/10W 75-F	613Z750C54		
-	1		R1G2	R-M-CHIP	1/10W 75-F	613Z750C54		
-	1		R1G3	R-M-CHIP	1/10W 150-J	613Z151C24		
-	1		R1G4	R-M-CHIP	1/10W 68-J	613Z680C24		
-	1		R1G5	R-M-CHIP	1/10W 15K-J	613Z153C24		
-	1		R1G6	R-M-CHIP	1/10W 39K-J	613Z393C24		
-	1		R1G7	R-M-CHIP	1/10W 100-J	613Z101C24		
-	1		R1G8	R-M-CHIP	1/10W 15K-J	613Z153C24		
-	1		R1G9	R-M-CHIP	1/10W 39K-J	613Z393C24		
-	1		R1GA	R-M-CHIP	1/10W 100-J	613Z101C24		
-	1		R1R1	R-M-CHIP	1/10W 75-F	613Z750C54		
-	1		R1R2	R-M-CHIP	1/10W 75-F	613Z750C54		
-	1		R1R3	R-M-CHIP	1/10W 150-J	613Z151C24		
-	1		R1R4	R-M-CHIP	1/10W 68-J	613Z680C24		
-	1		R1R5	R-M-CHIP	1/10W 15K-J	613Z153C24		
-	1		R1R6	R-M-CHIP	1/10W 39K-J	613Z393C24		
-	1		R1R7	R-M-CHIP	1/10W 100-J	613Z101C24		

**DWG. TITLE : ASSY-PWB-STAND**

GROUP 10: HM903DT, A902MT-v

GROUP		REV.	REF.NO	PART	DESCRIPTION	PART NO.	PRICE	REMARK
20	10							
-	1		R1R8	R-M-CHIP	1/10W 15K-J	613Z153C24		
-	1		R1R9	R-M-CHIP	1/10W 39K-J	613Z393C24		
-	1		R1RA	R-M-CHIP	1/10W 100-J	613Z101C24		
-	1		R201	R-C	1/4W 100-J	613Z101C11		
-	1		R203	R-C	1/4W 100-J	613Z101C11		
-	1		R204	R-M-CHIP	1/10W 33-J	613Z330C24		
-	1		R205	R-M-CHIP	1/10W 33-J	613Z330C24		
-	1		R207	R-M-CHIP	1/10W 100-J	613Z101C24		
-	1		R208	R-M-CHIP	1/10W 2R4K-J	613Z242C24		
-	1		R210	R-M-CHIP	1/10W 1K-J	613Z102C24		
-	1		R211	R-C	1/4W 5R6K-J	613Z562C11		
-	1		R212	R-M-CHIP	1/10W 6R8K-J	613Z682C24		
-	1		R213	R-C	1/4W 100-J	613Z101C11		
-	1		R217	R-C	1/4W 10K-J	613Z103C11		
-	1		R218	R-C	1/4W 10K-J	613Z103C11		
-	1		R219	R-M-CHIP	1/10W 1K-J	613Z102C24		
-	1		R222	R-C	1/4W 10K-J	613Z103C11		
-	1		R223	R-M-CHIP	1/10W 10K-J	613Z103C24		
-	1		R224	R-M-CHIP	1/10W 2R2K-J	613Z222C24		
-	1		R225	R-M-CHIP	1/10W 1K-J	613Z102C24		
-	1		R226	R-M-CHIP	1/10W 1K-J	613Z102C24		
-	1		R227	R-M-CHIP	1/10W 1K-J	613Z102C24		
-	1		R230	R-C	1/2W 10K-J	613Z103D81		
-	1		R231	R-C	1/2W 22K-J	613Z223D81		
-	1		R232	R-M-CHIP	1/10W 1K-J	613Z102C24		
-	1		R233	R-M-CHIP	1/10W 1K-J	613Z102C24		
-	1		R234	R-M-CHIP	1/10W 1K-J	613Z102C24		
-	1		R235	R-M-CHIP	1/10W 1K-J	613Z102C24		
-	1		R236	R-M-CHIP	1/10W 10K-F	613Z103C54		
-	1		R237	R-M-CHIP	1/10W 10K-F	613Z103C54		
-	1		R238	R-M-CHIP	1/10W 10K-F	613Z103C54		
-	1		R239	R-M-CHIP	1/10W 10K-F	613Z103C54		
-	1		R240	R-M-CHIP	1/10W 2R2K-F	613Z222C54		
-	1		R241	R-M-CHIP	1/10W 33K-F	613Z333C54		
-	1		R242	R-M-CHIP	1/10W 22K-F	613Z223C54		
-	1		R243	R-M-CHIP	1/10W 22K-F	613Z223C54		
-	1		R244	R-M-CHIP	1/10W 33K-F	613Z333C54		
-	1		R245	R-M-CHIP	1/10W 2R2K-F	613Z222C54		
-	1		R246	R-C	1/4W 5R6-J	613Z569C11		
-	1		R247	R-C	1/4W 5R6-J	613Z569C11		
-	1		R248	R-M-CHIP	1/10W 22K-F	613Z223C54		
-	1		R249	R-M-CHIP	1/10W 22K-F	613Z223C54		
-	1		R250	R-M-CHIP	1/10W 2R2-J	613Z229C24		
-	1		R251	R-MB	2W 68-J	612Z680C37		
-	1		R252	R-MB	2W 100-J	612Z101C37		
-	1		R253	R-C	1/4W 2R2-J	613Z229C11		
-	1		R254	R-C	1/4W 5R6-J	613Z569C11		
-	1		R256	R-C	1/4W 5R6-J	613Z569C11		
-	1		R257	R-M-CHIP	1/10W 22K-F	613Z223C54		
-	1		R258	R-M-CHIP	1/10W 22K-F	613Z223C54		
-	1		R259	R-M-CHIP	1/10W 2R2-J	613Z229C24		
-	1		R260	R-MB	2W 120-J	612Z121C37		
-	1		R261	R-MB	2W 120-J	612Z121C37		
-	1		R262	R-M-CHIP	1/10W 2R2-J	613Z229C24		
-	1		R2B1	R-C	1/4W 22-J	613Z220C11		
-	1		R2B3	R-M-CHIP	1/10W 22-J	613Z220C24		
-	1		R2B4	R-M-CHIP	1/10W 33-J	613Z330C24		
-	1		R2B5	R-C	1/2W 56-J	613Z560D81		
-	1		R2B6	R-M-CHIP	1/10W 1R8K-J	613Z182C24		
-	1		R2B7	R-C	1/4W 1K-J	613Z102C11		
-	1		R2B9	R-C	1/4W 2R2K-J	613Z222C11		
-	1		R2BB	R-M-CHIP	1/10W 330K-J	613Z334C24		

**DWG. TITLE : ASSY-PWB-STAND**

GROUP 10: HM903DT, A902MT-v

GROUP		REV.	REF.NO	PART	DESCRIPTION	PART NO.	PRICE	REMARK
20	10							
-	1		R2BC	R-C	1/4W 1M-J	613Z105C11		
-	1		R2G1	R-C	1/4W 22-J	613Z220C11		
-	1		R2G3	R-M-CHIP	1/10W 22-J	613Z220C24		
-	1		R2G4	R-M-CHIP	1/10W 33-J	613Z330C24		
-	1		R2G5	R-C	1/2W 56-J	613Z560D81		
-	1		R2G6	R-M-CHIP	1/10W 1R8K-J	613Z182C24		
-	1		R2G7	R-C	1/4W 1K-J	613Z102C11		
-	1		R2G9	R-C	1/4W 2R2K-J	613Z222C11		
-	1		R2GB	R-M-CHIP	1/10W 330K-J	613Z334C24		
-	1		R2GC	R-C	1/4W 1M-J	613Z105C11		
-	1		R2R1	R-C	1/4W 22-J	613Z220C11		
-	1		R2R3	R-M-CHIP	1/10W 22-J	613Z220C24		
-	1		R2R4	R-M-CHIP	1/10W 33-J	613Z330C24		
-	1		R2R5	R-C	1/2W 56-J	613Z560D81		
-	1		R2R6	R-M-CHIP	1/10W 1R8K-J	613Z182C24		
-	1		R2R7	R-C	1/4W 1K-J	613Z102C11		
-	1		R2R9	R-C	1/4W 2R2K-J	613Z222C11		
-	1		R2RB	R-M-CHIP	1/10W 330K-J	613Z334C24		
-	1		R2RC	R-C	1/4W 1M-J	613Z105C11		
-	1		R601	R-M-CHIP	1/10W 18K-J	613Z183C24		
-	1		R602	R-M-CHIP	1/10W 18K-J	613Z183C24		
-	1		R603	R-M-CHIP	1/10W 1R1K-J	613Z112C24		
-	1		R604	R-M-CHIP	1/10W 1R1K-J	613Z112C24		
-	1		R605	R-M-CHIP	1/10W 1K-J	613Z102C24		
-	1		R607	R-M-CHIP	1/10W 220-J	613Z221C24		
-	1		R608	R-M-CHIP	1/10W 220-J	613Z221C24		
-	1		R609	R-M-CHIP	1/10W 68K-J	613Z683C24		
-	1		R610	R-M-CHIP	1/10W 47K-J	613Z473C24		
-	1		R611	R-M-CHIP	1/10W 1K-J	613Z102C24		
-	1		R701	R-M-CHIP	1/10W 18-J	613Z180C24		
-	1		R702	R-M-CHIP	1/10W 18-J	613Z180C24		
-	1		R703	R-M-CHIP	1/10W 18-J	613Z180C24		
-	1		R704	R-M-CHIP	1/10W 18-J	613Z180C24		
-	1		R705	R-M-CHIP	1/10W 18-J	613Z180C24		
-	1		R706	R-M-CHIP	1/10W 18-J	613Z180C24		
-	1		R707	R-M-CHIP	1/10W 18-J	613Z180C24		
-	1		R708	R-M-CHIP	1/10W 18-J	613Z180C24		
-	1		R709	R-M-CHIP	1/10W 18-J	613Z180C24		
-	1		R710	R-M-CHIP	1/10W 18-J	613Z180C24		
-	1		R711	R-M-CHIP	1/10W 15K-J	613Z153C24		
-	1		R712	R-M-CHIP	1/10W 15K-J	613Z153C24		
-	1		R713	R-M-CHIP	1/10W 1R5K-J	613Z152C24		
-	1		R715	R-M-CHIP	1/10W 15K-J	613Z153C24		
-	1		R716	R-M-CHIP	1/10W 15K-J	613Z153C24		
-	1		R717	R-M-CHIP	1/10W 15K-J	613Z153C24		
-	1		R718	R-M-CHIP	1/10W 15K-J	613Z153C24		
-	1		R719	R-M-CHIP	1/10W 15K-J	613Z153C24		
-	1		R720	R-M-CHIP	1/10W 15K-J	613Z153C24		
-	1		R721	R-M-CHIP	1/10W 1M-J	613Z105C24		
-	1		R722	R-M-CHIP	1/10W 3R3K-J	613Z332C24		
-	1		R723	R-M-CHIP	1/10W 3R3K-J	613Z332C24		
-	1		R724	R-M-CHIP	1/10W 10K-J	613Z103C24		
-	1		R725	R-C	1/4W 1K-J	613Z102C11		
-	1		R732	THERMISTOR	RUSB120	744Z005A13		
-	1		R733	THERMISTOR	RUSB120	744Z005A13		
-	1		R734	THERMISTOR	RUSB120	744Z005A13		
-	1		R735	THERMISTOR	RUSB120	744Z005A13		
-	1		R901	R-C	1/2W 470K-J	613Z474D81		!
-	1		R903	R-FUSE	1/4W 10-J	614Z100A61		
-	1		R905	R-C	1/4W 680-J	613Z681C11		
-	1		R906	R-MB	1W R47-J	612Z478C27		
-	1		R907	R-M-CHIP	1/10W 3R3K-J	613Z332C24		

**DWG. TITLE : ASSY-PWB-STAND**

GROUP 10: HM903DT, A902MT-v

GROUP		REV.	REF.NO	PART	DESCRIPTION	PART NO.	PRICE	REMARK
20	10							
-	1		R908	R-MB	2W 100K-J	612Z104C37		
-	1		R909	R-MB	2W 100K-J	612Z104C37		
-	1		R910	FUSE	251005/20N5000	283Z221A21		
-	1		R920	R-FUSE	1/4W 15-J	614Z150A61		
-	1		R921	R-FUSE	1/4W 15-J	614Z150A61		
-	1		R922	R-FUSE	1W 6R8-J	614Z689B37		
-	1		R923	R-M-CHIP	1/10W 22K-J	613Z223C24		
-	1		R924	R-C	1/4W 470-J	613Z471C11		
-	1		R925	R-C	1/4W 270-J	613Z271C11		
-	1		R926	R-M-CHIP	1/10W 2R2K-J	613Z222C24		
-	1		R927	R-M-CHIP	1/10W 2R2K-F	613Z222C54		
-	1		R928	R-M-CHIP	1/10W 1K-J	613Z102C24		
-	1		R929	R-M-CHIP	1/10W 1K-F	613Z102C54		
-	1		R930	FUSE	251003/20N3000	283Z221A11		
-	1		R931	FUSE	20N3150	283Z223A11		
-	1		R932	R-M-CHIP	1/10W 10K-J	613Z103C24		
-	1		R933	R-M-CHIP	1/10W 10K-J	613Z103C24		
-	1		S150	SW	EVQ11A07K	129Z037A13		
-	1		S151	SW	EVQ11A07K	129Z037A13		
-	1		S152	SW	EVQ11A07K	129Z037A13		
-	1		S153	SW	EVQ11A07K	129Z037A13		
-	1		S154	SW	EVQ11A07K	129Z037A13		
-	1		S155	SW	EVQ11A07K	129Z037A13		
-	1		S901	SW-POWER	AJ7241WW	129Z041A10		!
-	1		SG201	NEON-LAMP	DSP-152M/YP-152N	789Z014A31		
-	1		SG202	NEON-LAMP	DSP-201M/YP-201N	789Z014A41		
-	1		SG2B1	NEON-LAMP	DSP-201M/YP-201N	789Z014A41		
-	1		SG2G1	NEON-LAMP	DSP-201M/YP-201N	789Z014A41		
-	1		SG2R1	NEON-LAMP	DSP-201M/YP-201N	789Z014A41		
-	1		T901	SWT		756Z017A10		!
-	1		TH150	THERMISTOR	NTSA0XH103EN6A0	744Z004A13		
-	1		TH901	THERMISTOR	10	744Z001A28		!
-	1		VR901	VR	B-2K	620Z202A60		!
-	1		X101	X'TAL	4MHZ	780Z012A13		
-	1		X701	X'TAL	6MHZ	780Z003A33		
-	1		CN101	CONNECTOR-SIGNAL	SDA-87112/SDA-89263/EHDE-15S	452Z723A10		!
-	1		CN102	CONNECTOR-SIGNAL	SDA-87112/SDA-89263/EHDE-15S	452Z723A10		!
-	1		CN601	CONNECTOR-SIGNAL	HSJ2000-01-010	452Z770A10		!
-	1		CN602	CONNECTOR-SIGNAL	HSJ2000-01-010	452Z770A10		!
-	1		CN701	CONNECTOR-SIGNAL	820-BFR-M13/ABDBC004C0	452Z775A10		!
-	1		CN702	CONNECTOR-SIGNAL	AACB2008A0	452Z771A30		!
-	1		CN703	CONNECTOR-SIGNAL	AACB2008A0	452Z771A30		!
-	2		A	CONNECTOR	A2501WV2-8P	452Z029G10		!
-	1		AC	CONNECTOR	A3963WV2-3P-2NC	452Z052A10		!
-	1		AD	CONNECTOR	A3963WV2-5P-2,4NC	452Z052B10		!
-	1		B	CONNECTOR	A2501WV2-7P	452Z029F10		!
-	1		C2	CONNECTOR	A2501WV2-6P	452Z029E10		!
-	1		CONV	CONNECTOR	A2501WV2-7P	452Z029F10		!
-	1		D	CONNECTOR	A2501WV2-4P	452Z029C10		!
-	2		E	CONNECTOR	A2501WV2-2P	452Z029A10		!
-	1		G	CONNECTOR	A2501WV2-6P	452Z029E10		!
-	1		G1	CONNECTOR	A2501WV2-5P	452Z029D10		!
-	1		L	CONNECTOR	A2501WV2-3P	452Z029B10		!
-	1		NS	CONNECTOR	A2501WV2-2P	452Z029A10		!
-	1		R	CONNECTOR	A2501WV2-2P	452Z029A10		!
-	2			GT-PIN	DIA2.36	452Z902A10		
-	19			EYELET		679D022A20		
-	2			RADIATOR		595D313A10		
-	1			RADIATOR	OSH-2425/PR1724/790Z006-10	790Z006A10		
-	1			RADIATOR	OSV-1525B	790Z018B10		
-	1			PWB-STAND		210R102-01		!

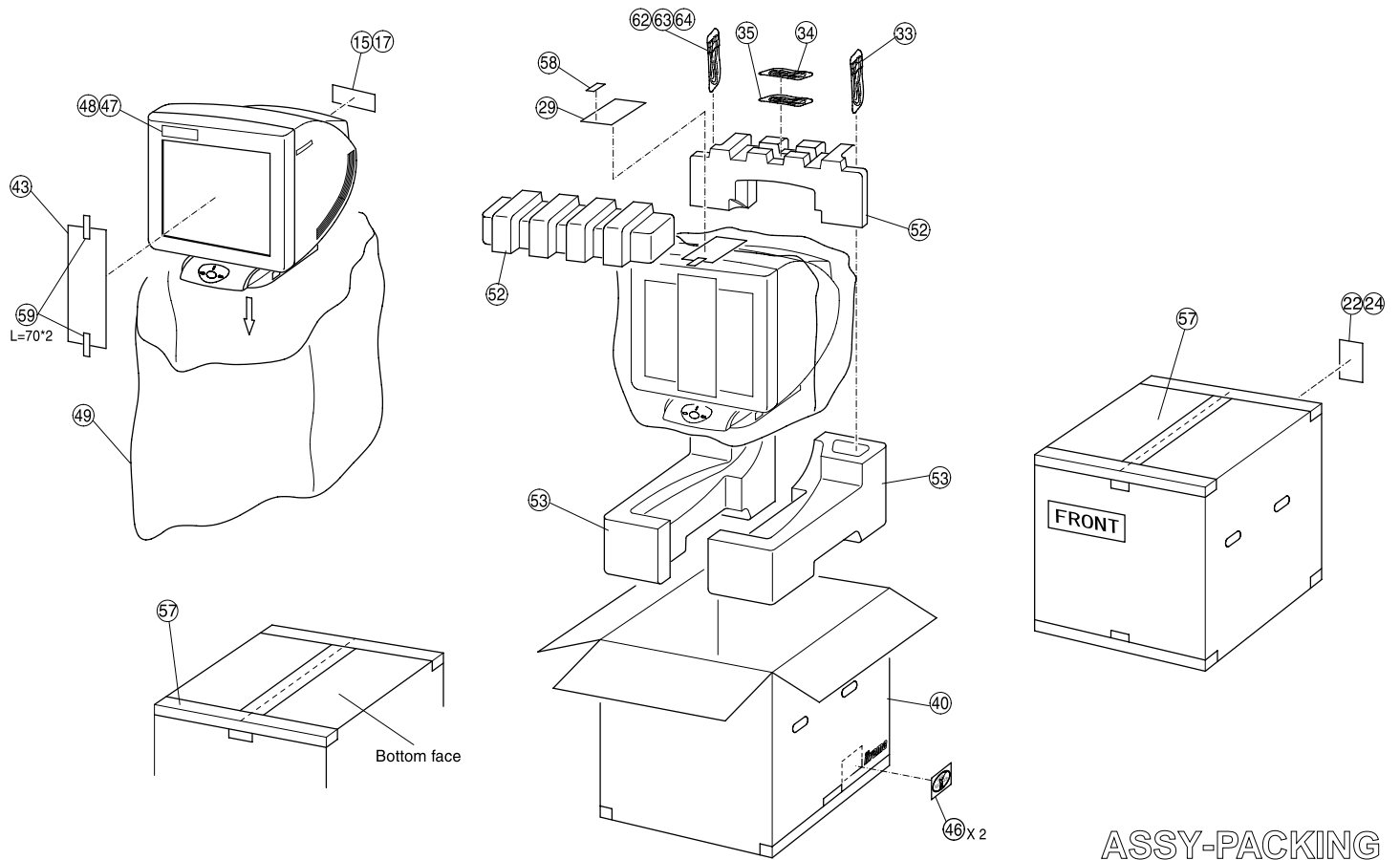
**DWG. TITLE : SUB-MATERIAL**

GROUP 10: HM903DT, A902MT-v

GROUP		REV.	REF.NO	PART	DESCRIPTION	PART NO.	PRICE	REMARK
20	10							
-	#		AA	SILICONE-GUM	TSE3940/KE3490	090Z001A10		!
-	#		AB	SILICONE-GUM	TSE3940	090Z001A20		!
-	#		AC	SILICONE-GUM	TSE3941	090Z032A01		!
-	#		AD	SILICONE-GUM	KE3480	090Z018A01		!
-	#		AE	SILICONE-GUM	TSE3941	090Z032A02		!
-	#		AF	SILICONE-GUM	KE40RTV	090Z009A30		!
-	#		AH	SILICONE-GREASE	YG6260/G747	090Z007A10		
-	#		AJ	SILICONE-GREASE	KS660	090Z027A01		
-	#		AK	SILICONE-GREASE	G501	090Z016A01		
-	#		AL	SILICONE-GREASE	TSK5370	090Z028A01		
-	#		AM	BOND	LEICHLOCK-NO.3-C	090Z010A10		
-	#		AP	BOND	DN297A	090Z012A10		
-	#		AQ	BOND	DN297A	090Z012A20		
-	#		AR	BOND	3609/348/MR-8121	090Z031A01		
-	#		AS	BOND	EC3748-TC-Q	090Z014A10		
-	#		AU	SOLDER-ROSIN	E-28RH60-B/RS3/X52/115A-1	090Z019A01		
-	#		AV	SOLDER-ROSIN	E-28RH60-B/RS3/115A-1	090Z019A02		
-	#		AW	SOLDER-ROSIN	E-28RH60-B/RS3/115A-1	090Z019A03		
-	#		AX	SOLDER-ROSIN	SE4-M952K	090Z030A02		
-	#		AY	SOLDER-ROSIN	H63A/H63S/BAR63/37/63EN/H63E	090Z023A01		
-	#		AZ	SOLDER-ROSIN	T6204/221CM5/PS130B	090Z030A01		
-	#		BA	FLUX	CF330VH/130VS/TNF21V	090Z021A01		
-	#		BB	FLUX	ULF-300VZ-2/ULF-300VZ-3	090Z021A02		
-	#		BC	DILUTION		090Z022A01		
-	#		BE	CLEAN-COAT	TC-110M/TC-131L	090Z026A01		
-	#		BG	STAPLE	TB18	811Z001A01		
-	#		BJ	PAINT	30-10	090Z020A01		
-	#		BK	PAINT	WHITE	090Z029A01		
-	#		BM	LABEL	TACK-TITLE-70-4IN-G	851Z001A04		
-	#		BP	SUB-PARTS	JK-WIPER-150S	090Z033A01		
-	#		BT	UL-TAPE	NO.303	830P100A10		
-	#		BU	DF-TAPE	#575	890P329A10		
-	#		BV	ACETATE-TAPE	NO.570F/AC04	830Z014A01		
-	#		BY	TAPE	T222A	830Z011A01		
-	#		CA	MAGNET	B-1030	890P302A10		
-	#		CB	MAGNET	OP-B1F	890P326A10		
-	#		CC	MAGNET	M-594(58854900)	890Z008A01		
-	#		CD	MAGNET	138D	890Z010A01		
-	#		CE	ITC-PARTS	FERRITE-PIECE-A	890Z011A01		

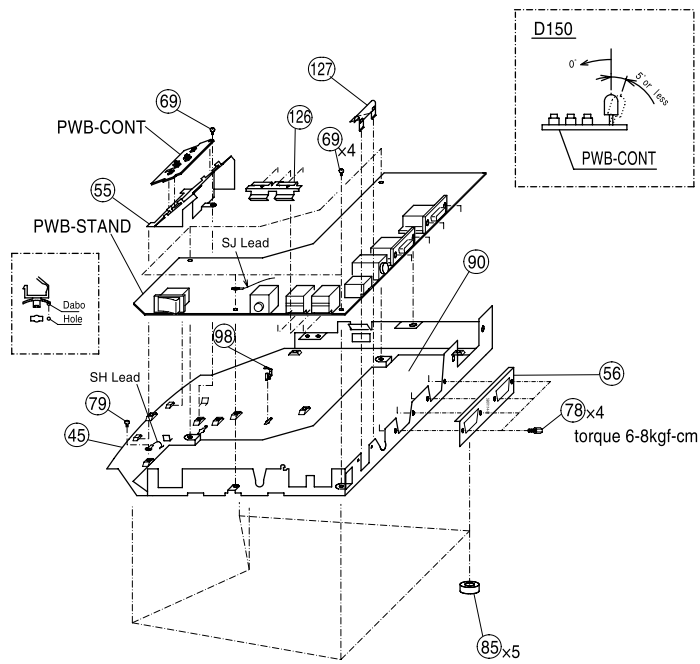
## 6. EXPLODED VIEW

Note: The numbers in this exploded view are the same as the reference numbers in the Chapter 5.

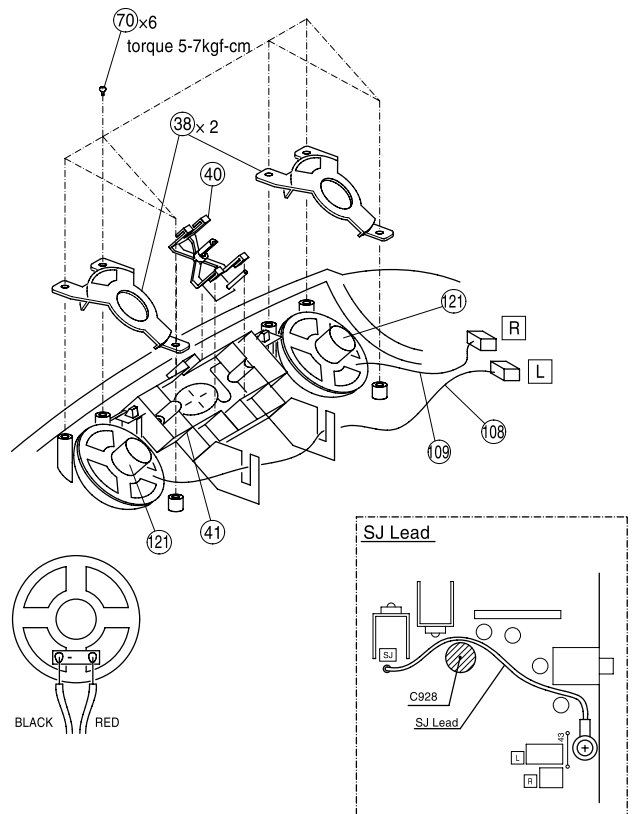


ASSY-PACKING

ASSY-1



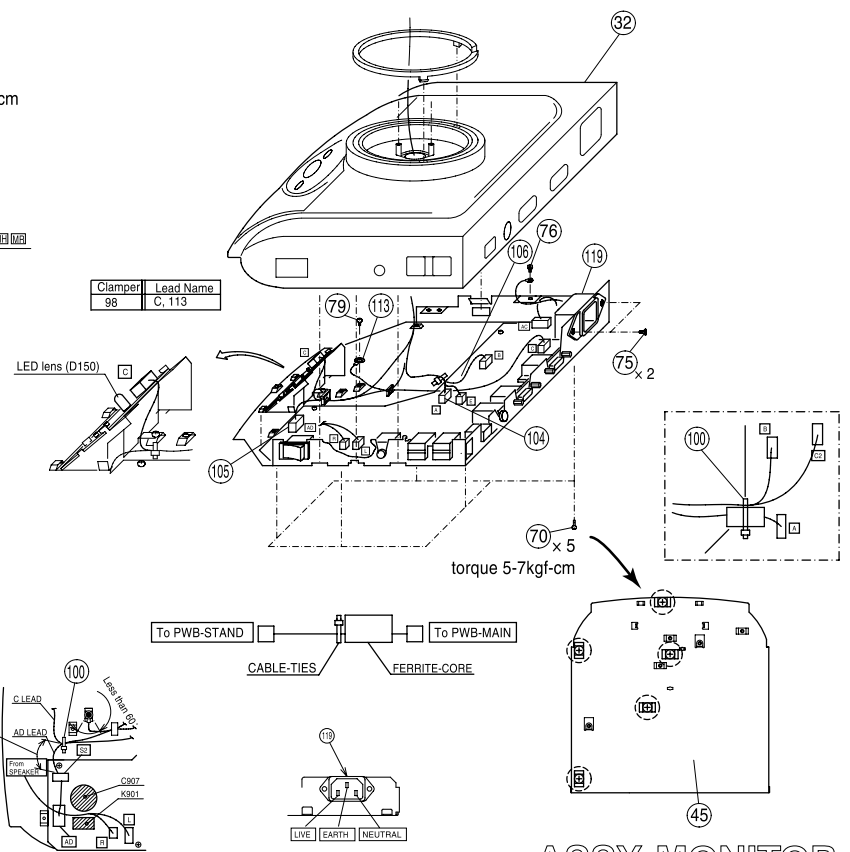
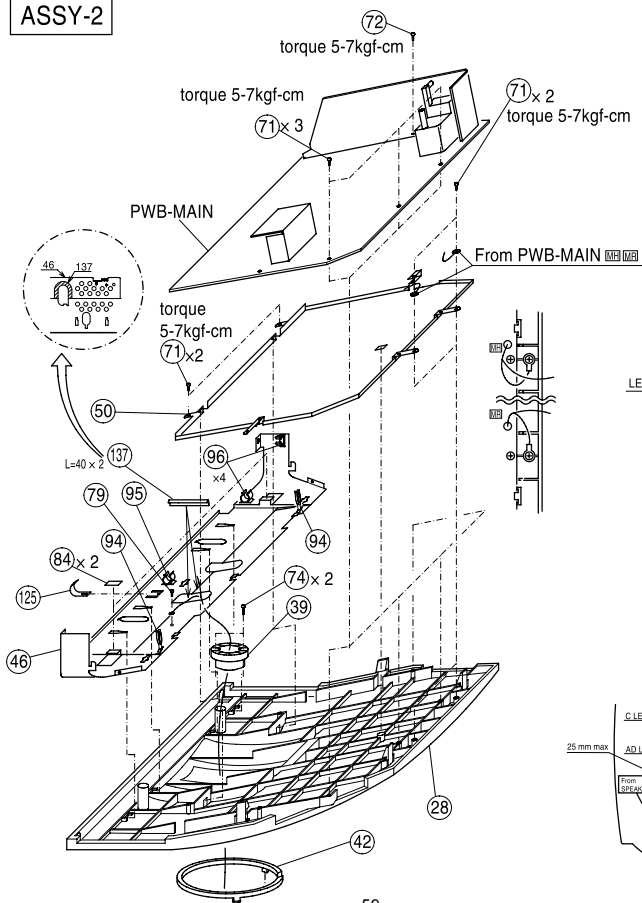
Note: Except where indicate otherwise, all screw torque is 9-11kgf-cm in ASSY-MONITOR.



ASSY-MONITOR



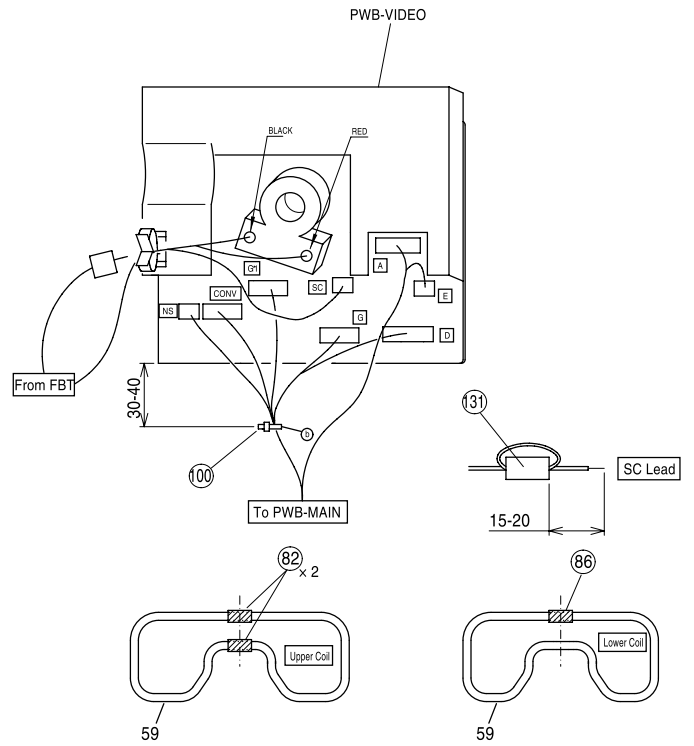
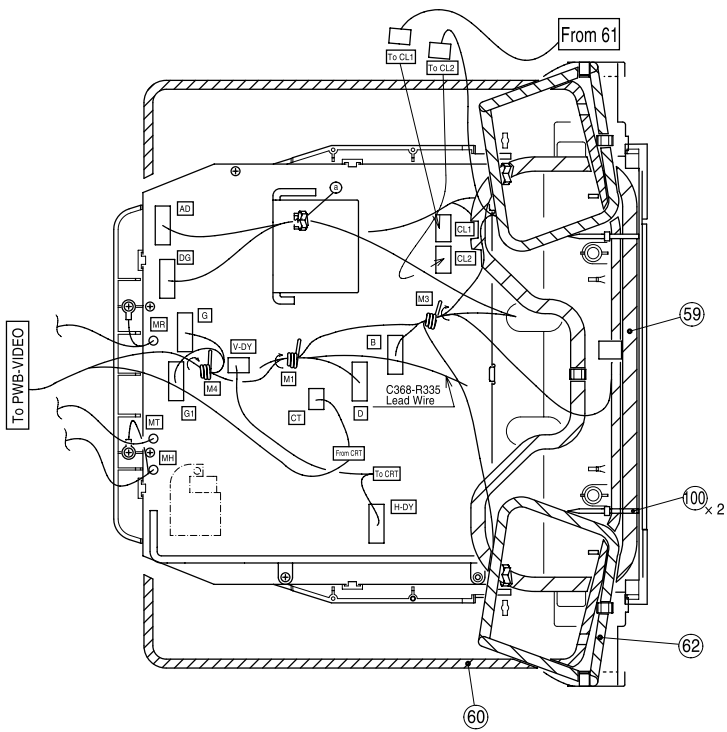
ASSY-2



Clamp#	Lead Name
98	C.113

ASSY-MONITOR

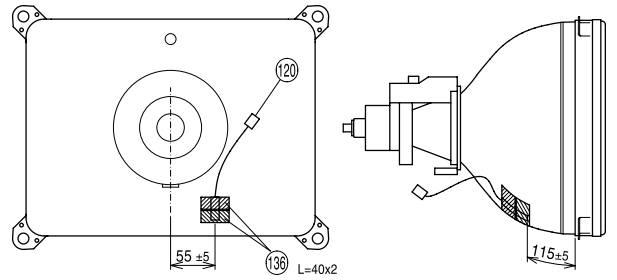
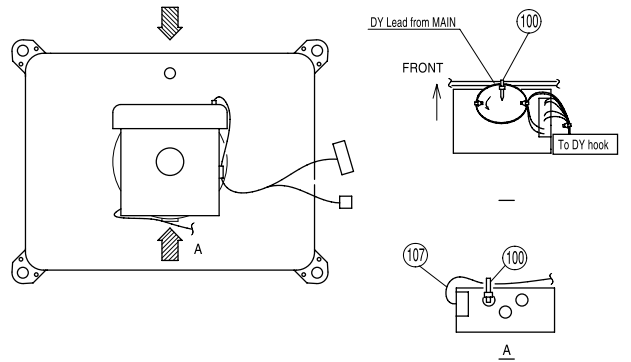
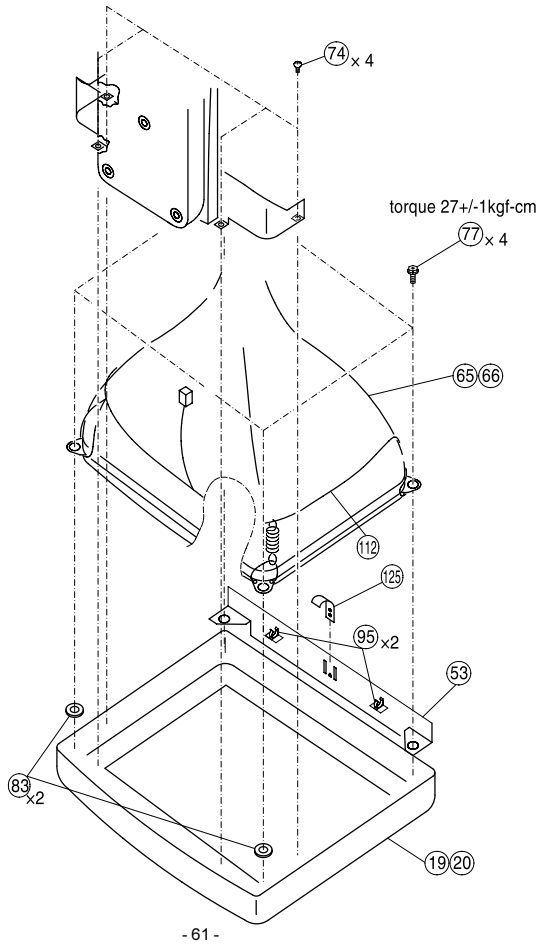
ASSY-3



Clamper	Lead Name
a	AD, DG
b	D, G, G1, CONV, NS
M1	A, D, NS, C368-R335
M3	A, B, NS
M4	62
	A, D, G, G1, NS

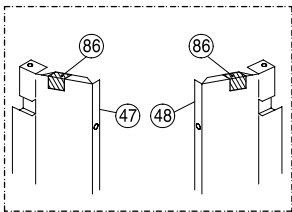
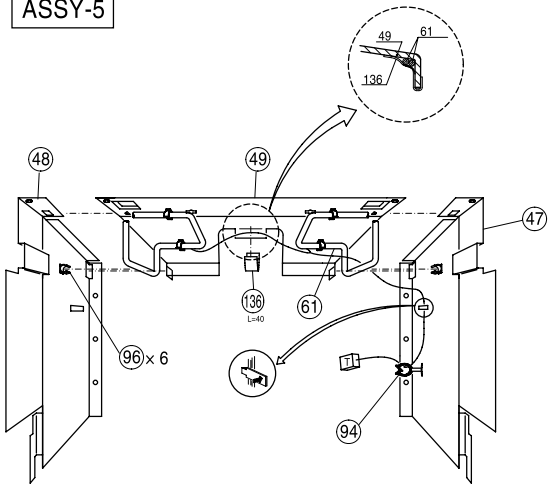
ASSY-MONITOR

ASSY-4

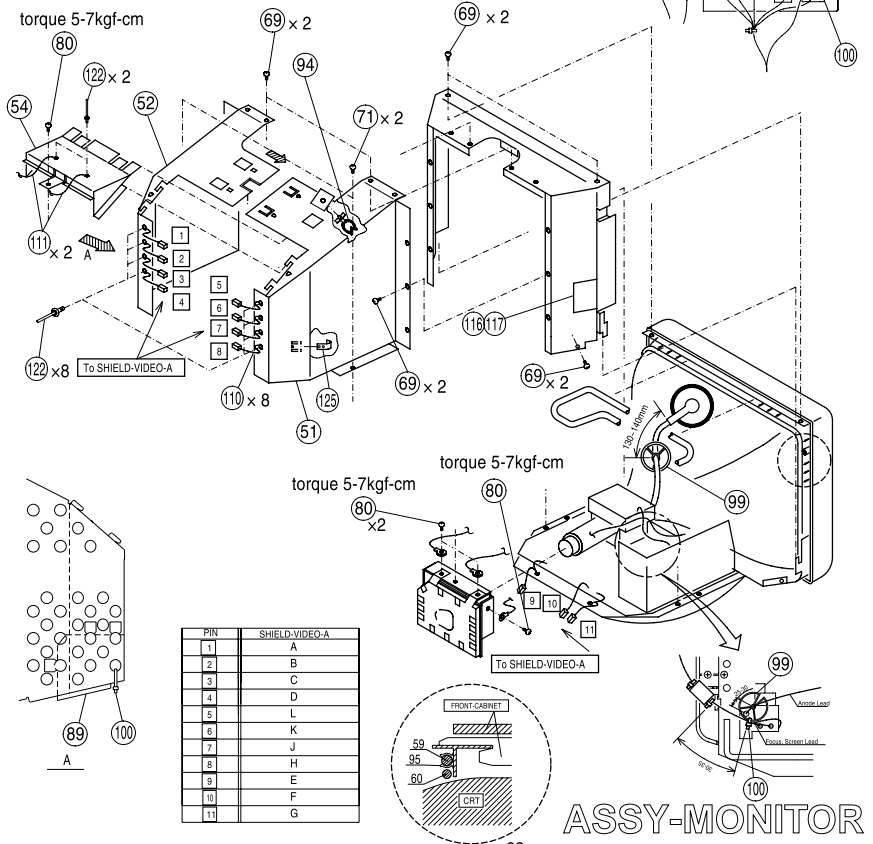


ASSY-MONITOR

ASSY-5

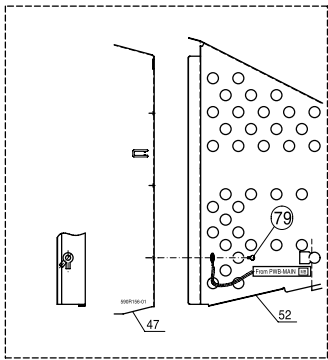
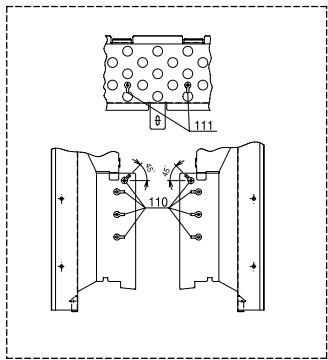


ASSY-6-1

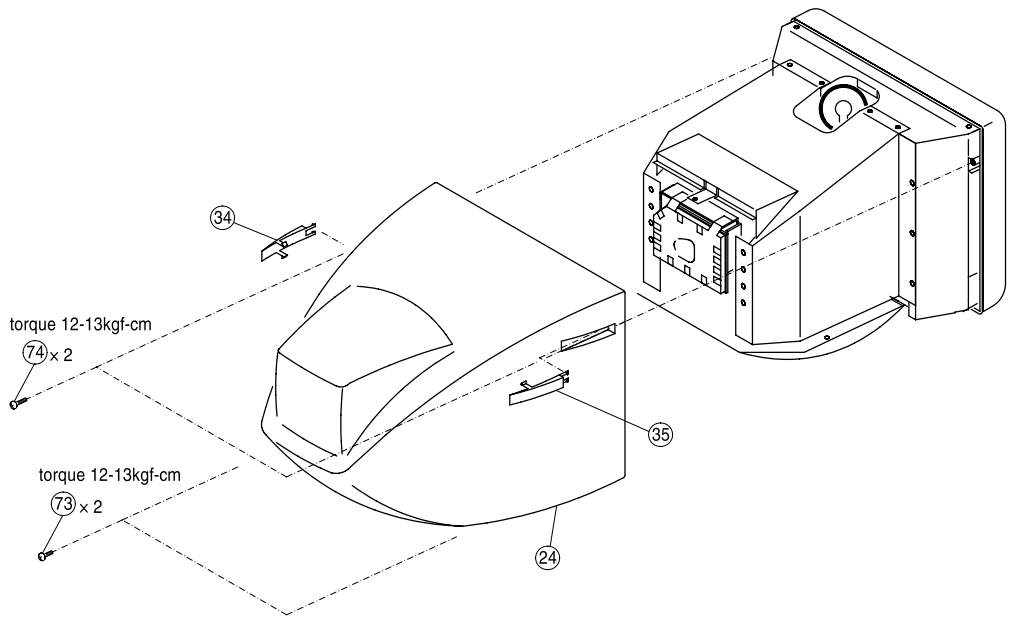


ASSY-MONITOR

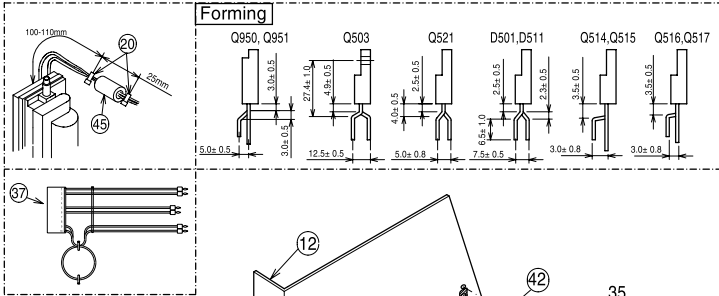
ASSY-6-2



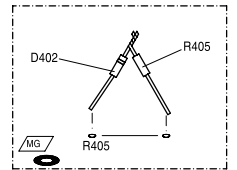
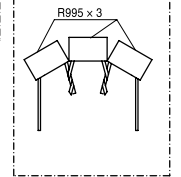
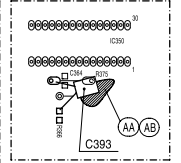
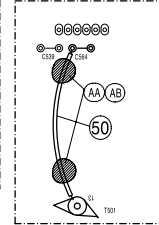
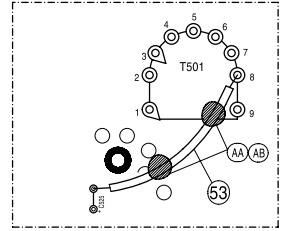
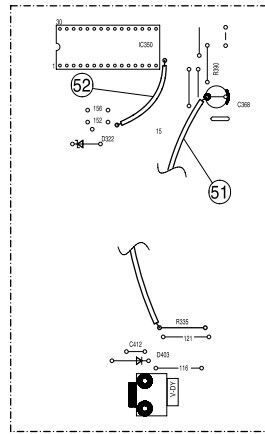
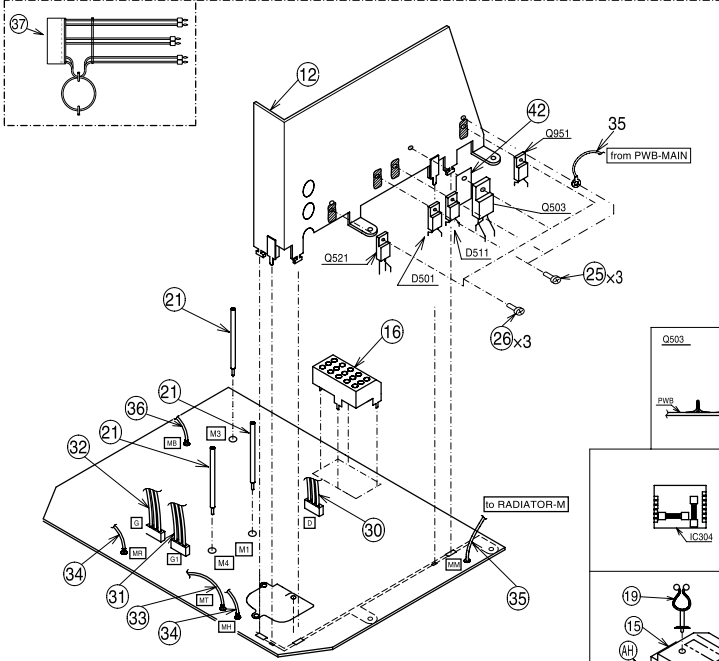
ASSY-7



ASSY-MONITOR



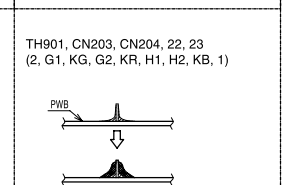
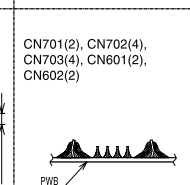
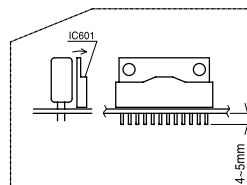
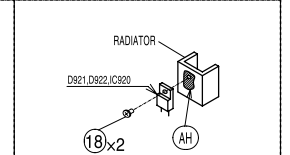
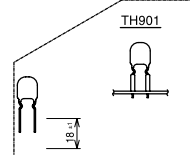
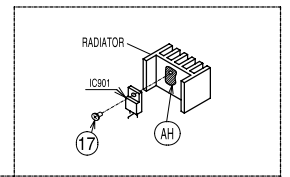
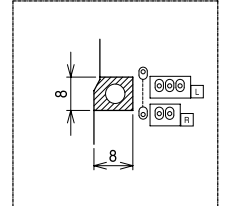
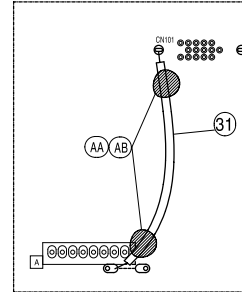
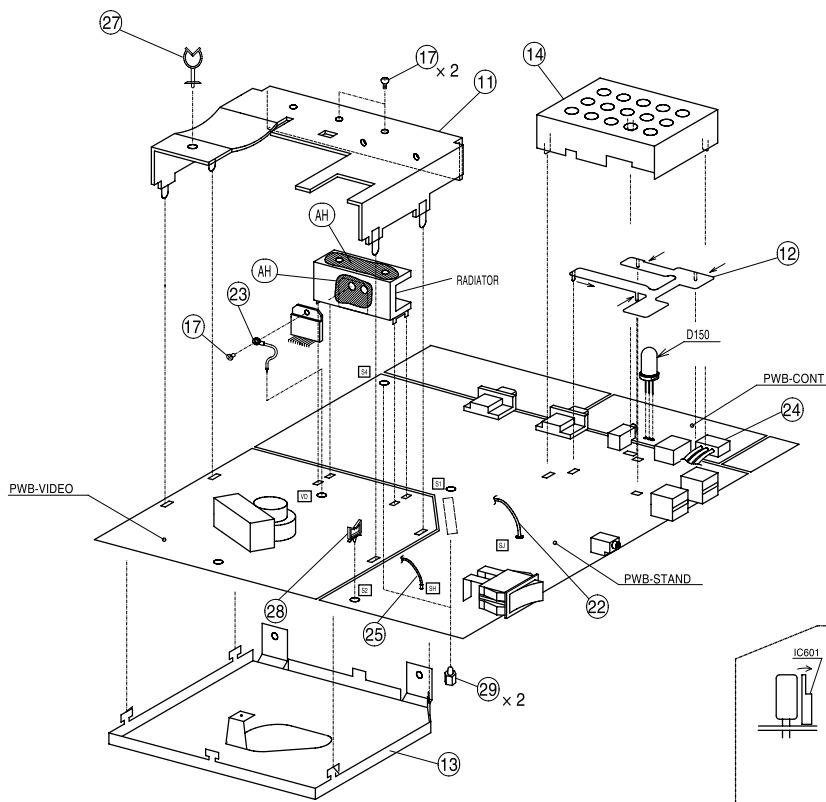
Note: Except where indicate otherwise, all screw torque is 3-5kgf-cm in ASSY-PWB-MAIN.



<p>Q503</p>	<p>RADIATOR D972</p>	<p>TH950</p>
<p>IC204</p>	<p>RADIATOR Q516, Q517</p>	<p>TH950, C959, T501, IC401</p>
<p>IC951</p>	<p>RADIATOR D971, IC853</p>	<p>RADIATOR D950</p>
<p>IC950</p>	<p>RADIATOR IC401</p>	<p>RADIATOR D950</p>

# ASSY-PWB-MAIN

Note: Except where indicate otherwise, all screw torque is 3-5kgf-cm in ASSY-PWB-STAND.



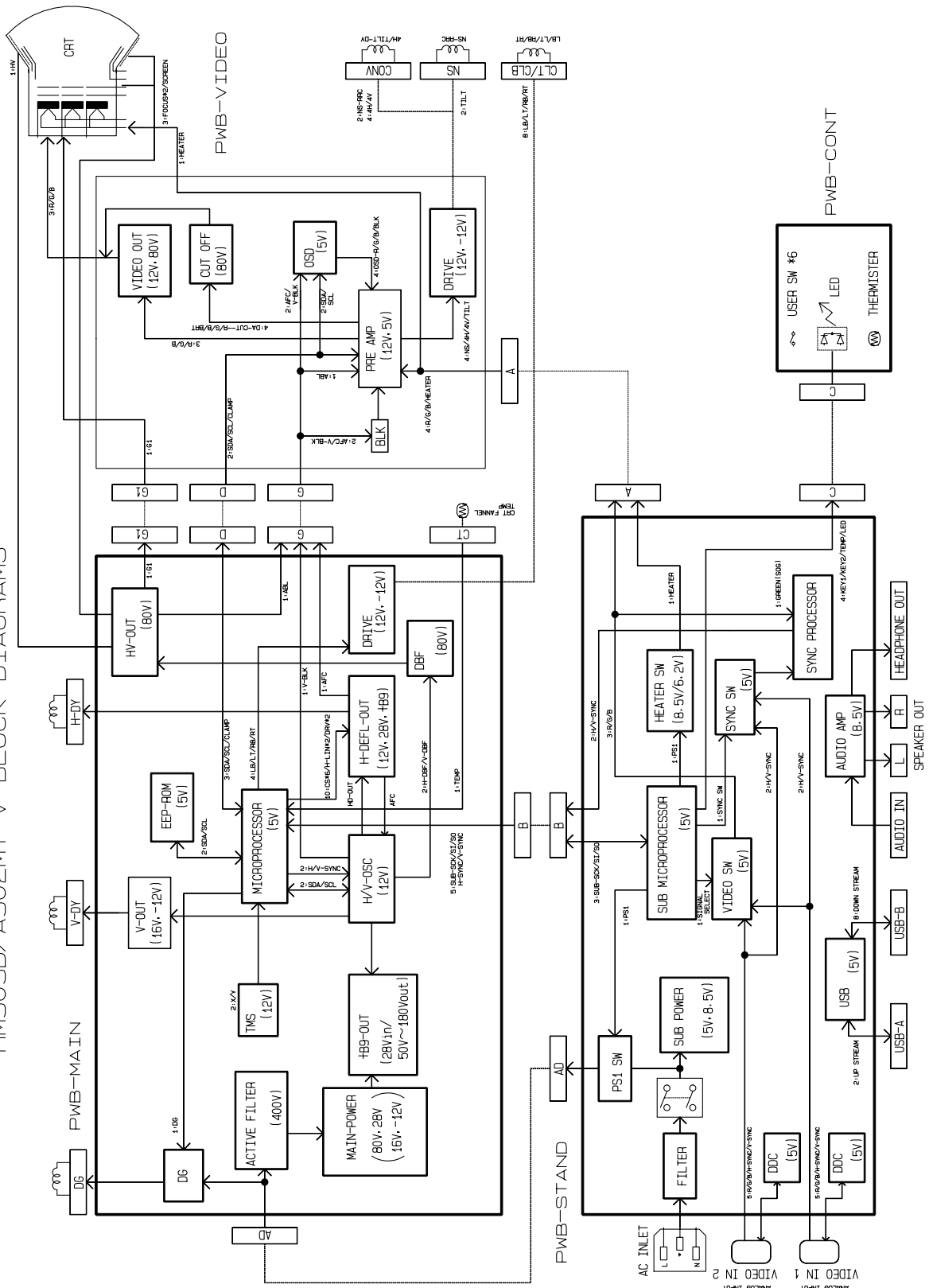
CN701(2), CN702(4),  
CN703(4), CN601(2),  
CN602(2)

TH901, CN203, CN204, 22, 23  
(2, G1, KG, G2, KR, H1, H2, KB, 1)

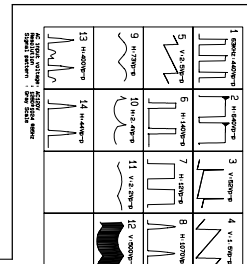
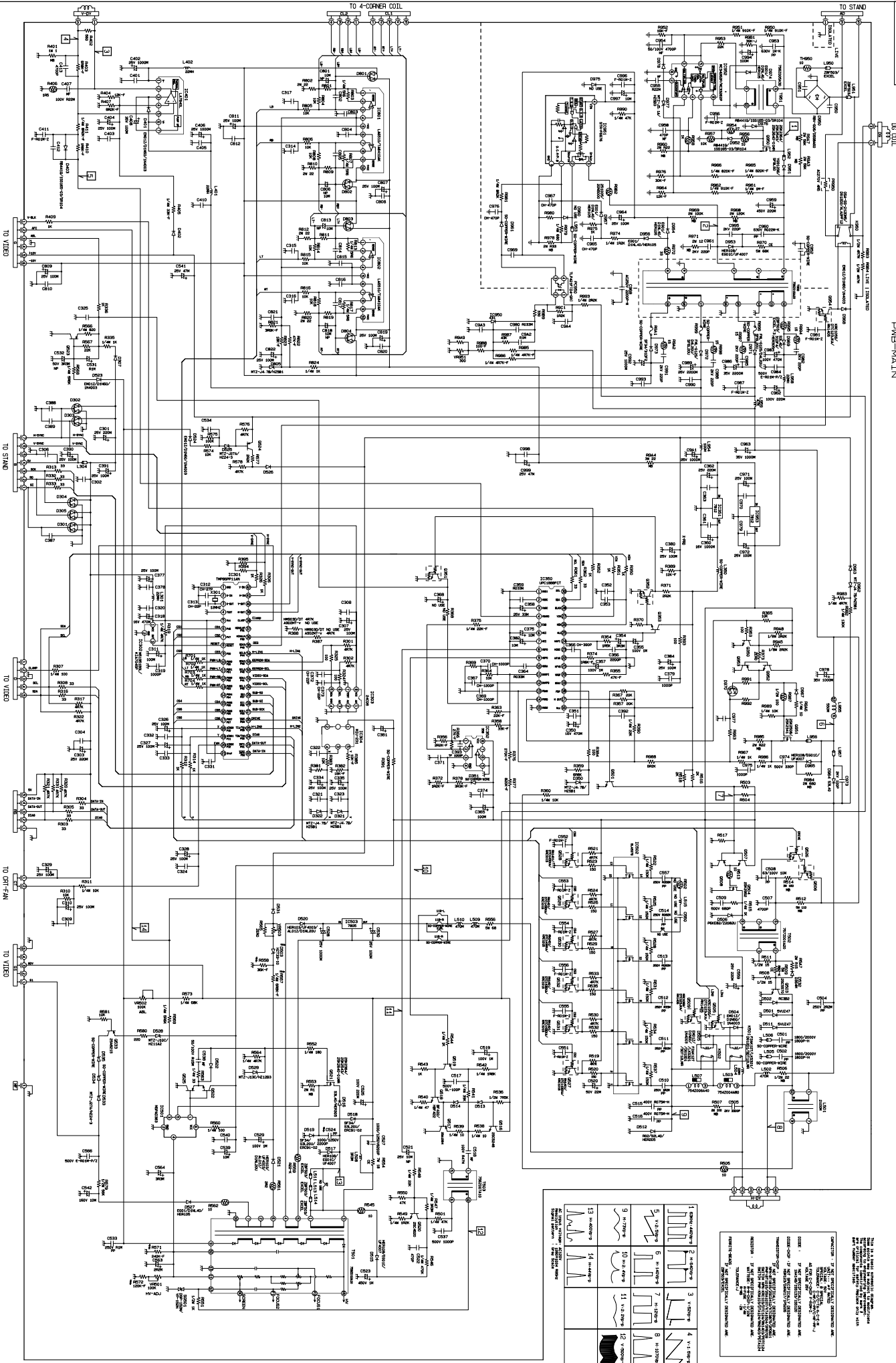
## ASSY-PWB-STAND

# 7. DIAGRAMS

HM903D/A902MT-V BLOCK DIAGRAMS







REVISIONS

NO.	DATE	BY	REASON
1	2001-05-11	M. HAYASHI	DESIGNED
2	2001-05-11	H. TOBOROKI	CHECKED
3	2001-05-11		APPROVED

CHANGE

DATE 2001-05-11

DESIGNED M. HAYASHI

CHECKED H. TOBOROKI

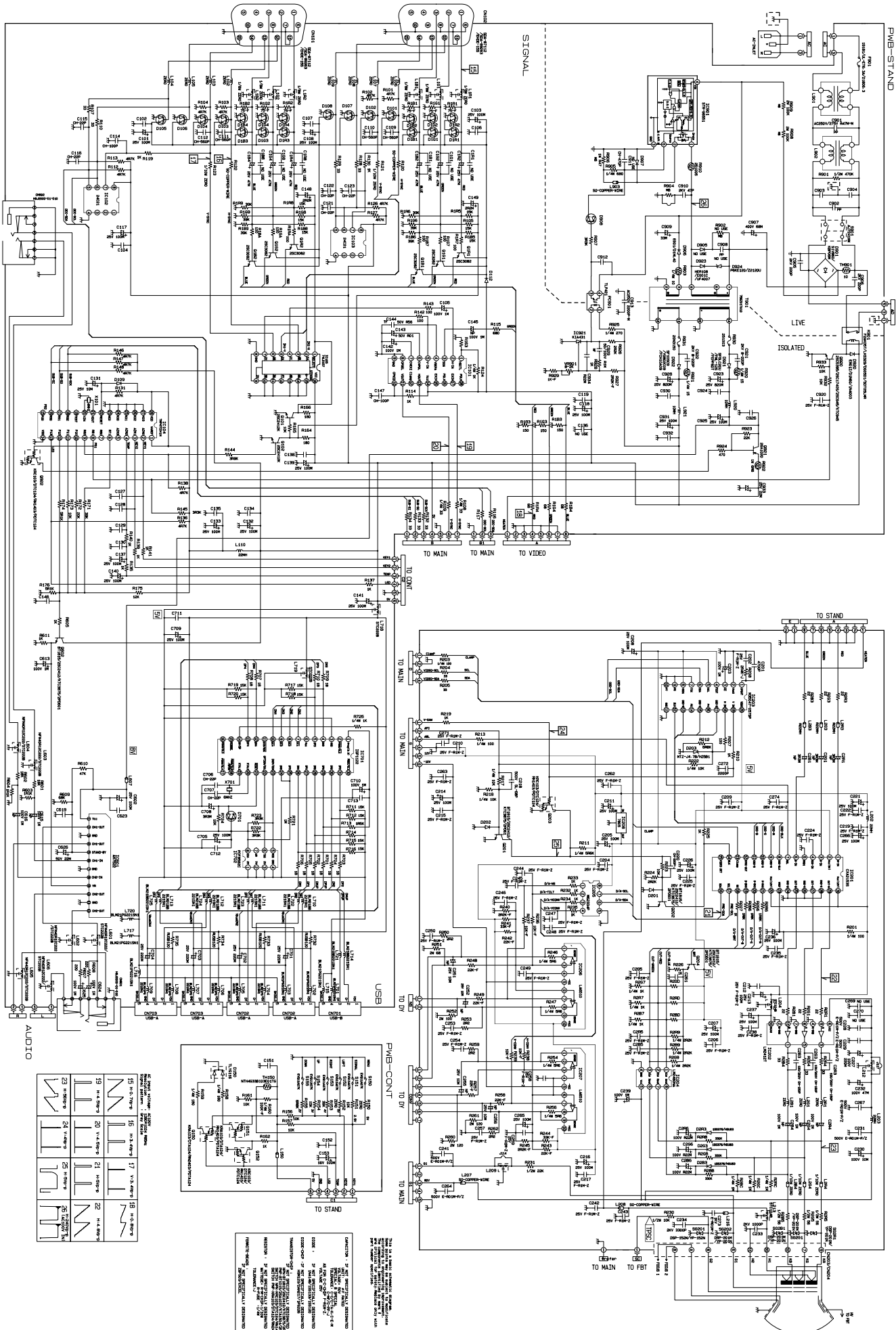
APPROVED

98050221/1

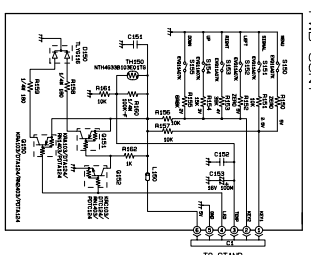
ITYAMA CORPORATION

CIRCUIT DIAGRAM

DEPART. TITLE



NO.	REV.	DATE	BY	CHKD.	APPV.
1					
2					
3					
4					
5					
6					
7					
8					
9					
10					
11					
12					
13					
14					
15					
16					
17					
18					
19					
20					
21					
22					
23					
24					
25					
26					



CAUTION: IF ANY PARTS ARE REWORKED, THE BOARD MUST BE RE-TESTED. THE BOARD MUST BE RE-TESTED AFTER ANY REPAIRS. THE BOARD MUST BE RE-TESTED AFTER ANY REPAIRS. THE BOARD MUST BE RE-TESTED AFTER ANY REPAIRS.

IYAMA CORPORATION	
DATE	2001-05-10
DESIGN	DESIGNED
CHECKED	APPROVED
NAME	M. MATSUO
NO.	
REV.	
DATE	
BY	
CHKD.	
APPV.	

DRAWING TITLE: CIRCUIT DIAGRAM  
 9805022 1/2