

# P45U V10

## GP106 8GB/4GB GDDR5, 256b, 256Mx32/128MX32 Tall DVI-D + HDMI+ DP

### TABLE OF CONTENTS

Page	Description
1	Table of Contents
2	Block Biagram
3	PCI Express
4	GPU FB_AB
5	MEMORY: FBA[31:0]
6	MEMORY: FBA[63:32]
7	MEMORY: FBB[31:0]
8	MEMORY: FBB[63:32]
9	MEM FB_AB PWR
10	GPU FB_CD
11	MEMORY: FBC[31:0]
12	MEMORY: FBC[63:32]
13	MEMORY: FBD[31:0]
14	MEMORY: FBD[63:32]
15	MEM FB_CD PWR
16	GPU PWR & GND
17	GPU Decoupling
18	IFPAB DVI-D-DL
19	IFPE UNUSED
20	IFPF UNUSED
21	IFPC HDMI
22	IFPD DP
23	MIOA/B Interface and Frame Lock
24	MISC1: Fan, Thermal, JTAG, GPIO,STEREO
25	MISC2: ROM, XTAL,STRAPS

Page	Description
26	PS: 1V8_PLL, 1V8_AON
27	PS: 5V, PEX_VDD
28	PS: NV3V3, NV12V
29	PS: FBVDD
30	PS: NVVDD Controller
31	PS: NVVDD Phase 1-4
32	PS:Blank page
33	PS: Input, Filtering, and Monitoring
34	PS: 12V Power Steering,PSI Control & LED
35	PS: Shut Down and Sequencing
36	PS: GC6 MISC
37	MECH_SN EEPRON

		Galaxy Microsystems (HK) Ltd.	
Page Name: Table of Contents			
Size: Custom	Project Name: P45U	Design By: Carson	Rev: V10
Date: Thursday, December 28, 2017	Sheet 1 of 37		
PROPERTY NOTE: This document contains information confidential and property to Galaxy Microsystems (HK) Ltd.			

ASSEMBLY PAGE DETAIL	<ASSEMBLY_DESCRIPTION> Table of Contents
----------------------	---

ALL NVIDIA DESIGN SPECIFICATIONS, REFERENCE SPECIFICATIONS, REFERENCE BOARDS, FILES, DRAWINGS, DIAGNOSTICS, LISTS AND OTHER DOCUMENTS OR INFORMATION (TOGETHER AND SEPARATELY, 'MATERIALS') ARE BEING PROVIDED 'AS IS'. THE MATERIALS MAY CONTAIN KNOWN AND UNKNOWN VIOLATIONS OR DEVIATIONS OF INDUSTRY STANDARDS AND SPECIFICATIONS. NVIDIA MAKES NO WARRANTIES, EXPRESSED, IMPLIED, STATUTORY OR OTHERWISE WITH RESPECT TO THE MATERIALS OR OTHERWISE, AND EXPRESSLY DISCLAIMS ALL IMPLIED WARRANTIES INCLUDING, WITHOUT LIMITATION, THE WARRANTIES OF DESIGN, OF NONINFRINGEMENT, MERCHANTABILITY OR FITNESS FOR A PARTICULAR PURPOSE, OR ARISING FROM A COURSE OF DEALING, TRADE USAGE, TRADE PRACTICE, OR INDUSTRY STANDARDS.

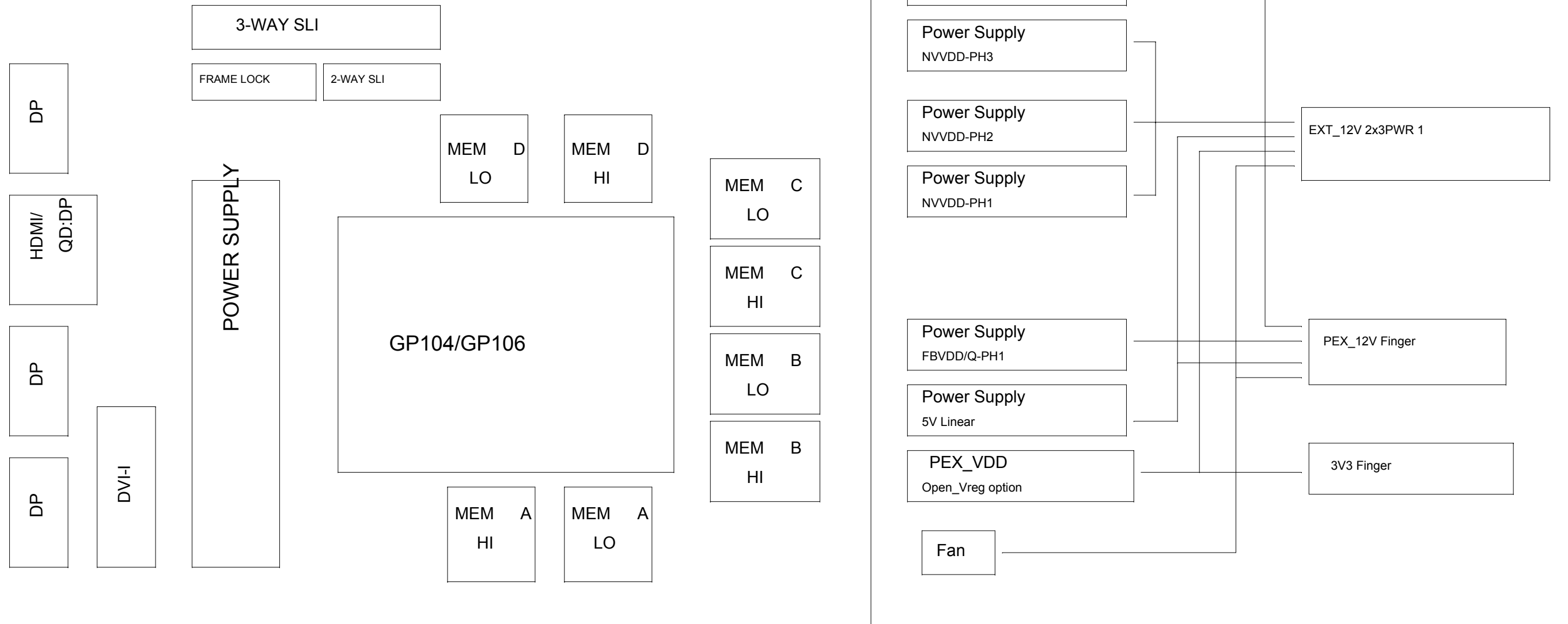

ALL NVIDIA DESIGN SPECIFICATIONS, REFERENCE SPECIFICATIONS, REFERENCE BOARDS, FILES, DRAWINGS, DIAGNOSTICS, LISTS AND OTHER DOCUMENTS OR INFORMATION (TOGETHER AND SEPARATELY, 'MATERIALS') ARE BEING PROVIDED 'AS IS'. THE MATERIALS MAY CONTAIN KNOWN AND UNKNOWN VIOLATIONS OR DEVIATIONS OF INDUSTRY STANDARDS AND SPECIFICATIONS. NVIDIA MAKES NO WARRANTIES, EXPRESSED, IMPLIED, STATUTORY OR OTHERWISE WITH RESPECT TO THE MATERIALS OR OTHERWISE, AND EXPRESSLY DISCLAIMS ALL IMPLIED WARRANTIES INCLUDING, WITHOUT LIMITATION, THE WARRANTIES OF DESIGN, OF NONINFRINGEMENT, MERCHANTABILITY OR FITNESS FOR A PARTICULAR PURPOSE, OR ARISING FROM A COURSE OF DEALING, TRADE USAGE, TRADE PRACTICE, OR INDUSTRY STANDARDS.

ASSEMBLY PAGE DETAIL	<ASSEMBLY_DESCRIPTION> Block Diagram
-------------------------	---

		Galaxy Microsystems (HK) Ltd.	
Page Name: <b>Block Diagram</b>			
Size Custom	Project Name: <b>P45U</b>	Design By: Carson	Rev V10
Date: Thursday, December 28, 2017	Sheet 2 of 37		
PROPERTY NOTE: This document contains information confidential and property to Galaxy Microsystems (HK) Ltd.			

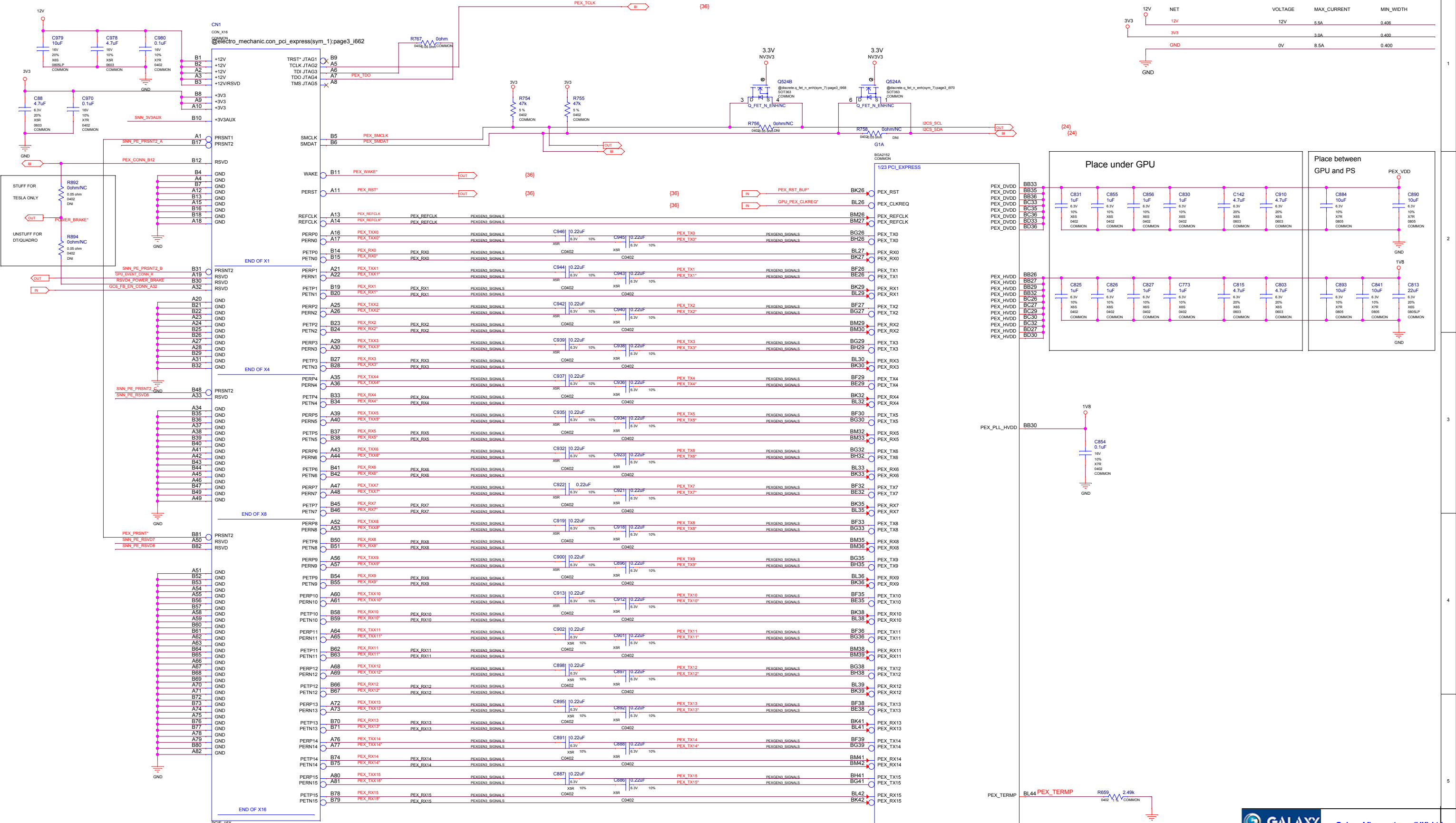

ASSEMBLY PAGE DETAIL

ASSEMBLY DESCRIPTION

PCI Express

ALL NVIDIA DESIGN SPECIFICATIONS, REFERENCE SPECIFICATIONS, REFERENCE BOARDS, FILES, DRAWINGS, DIAGNOSTICS, LISTS AND OTHER DOCUMENTS OR INFORMATION (TOGETHER AND SEPARATELY, "MATERIALS") ARE BEING PROVIDED "AS IS". THE MATERIALS MAY CONTAIN KNOWN AND UNKNOWN VIOLATIONS OR DEVIATIONS OF INDUSTRY STANDARDS AND SPECIFICATIONS. NVIDIA MAKES NO WARRANTIES, EXPRESSED, IMPLIED, STATUTORY OR OTHERWISE WITH RESPECT TO THE MATERIALS OR OTHERWISE, AND EXPRESSLY DISCLAIMS ALL IMPLIED WARRANTIES INCLUDING, WITHOUT LIMITATION, THE WARRANTIES OF DESIGN, OF NONINFRINGEMENT, MERCHANTABILITY OR FITNESS FOR A PARTICULAR PURPOSE, OR ARISING FROM A COURSE OF DEALING, TRADE USAGE, TRADE PRACTICE, OR INDUSTRY STANDARDS.

**GALAXY** Galaxy Microsystems (HK) Ltd.

Page Name: PCI Express

Size: Custom	Project Name: P45U	Design By: Carson	Rev: V10
Date: Thursday, December 28, 2017	Sheet: 3	of: 37	

PROPERTY NOTE: This document contains information confidential and property to Galaxy Microsystems (HK) Ltd.

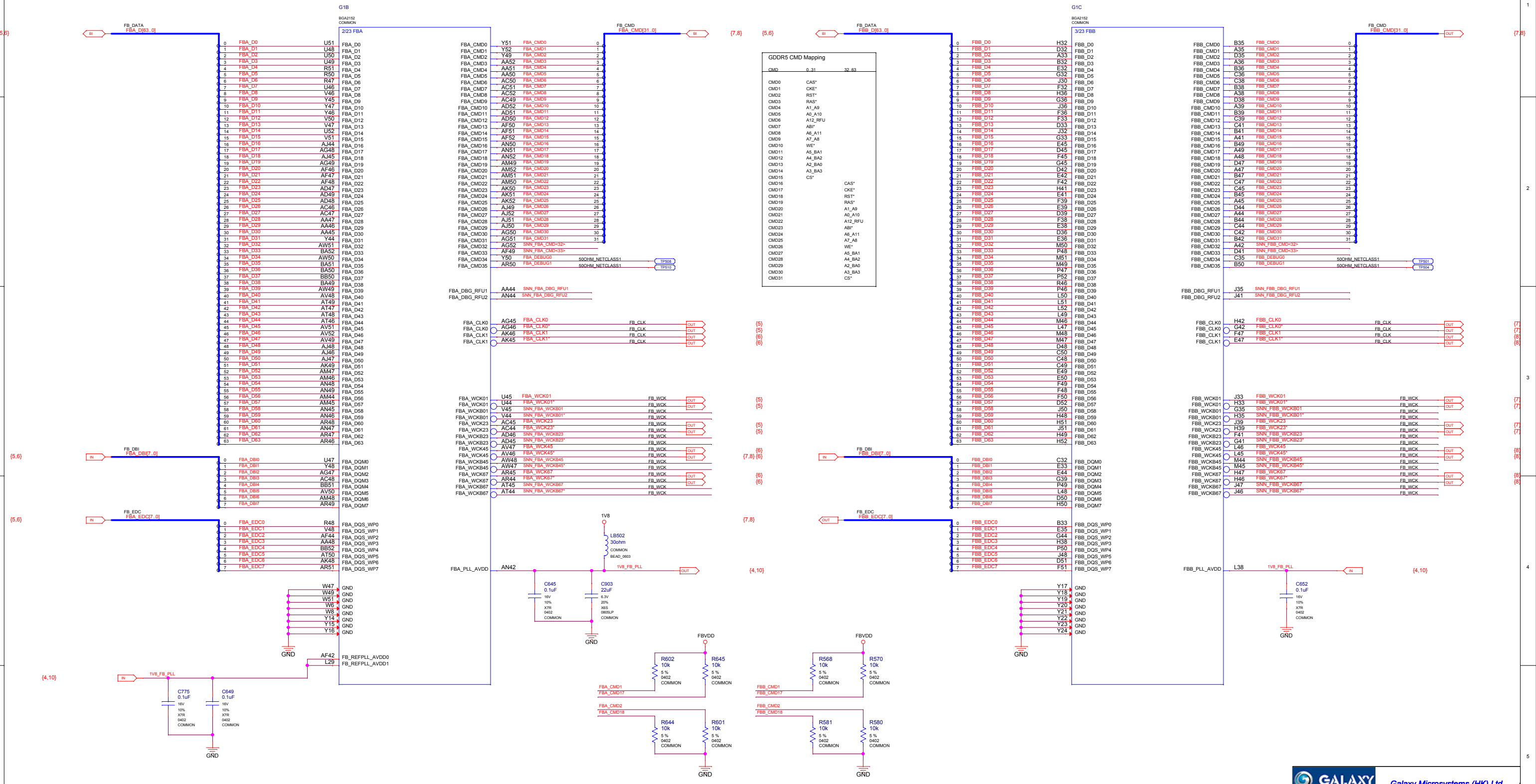

**GDDR5 CMD Mapping**

CMD	0..31	32..63
CM00	CAS*	
CM01	CKE*	
CM02	RST*	
CM03	RAS*	
CM04	A1_A9	
CM05	A0_A10	
CM06	A12_RFU	
CM07	AB*	
CM08	AB_A11	
CM09	AT_A8	
CM10	WE*	
CM11	AS_BA1	RAS*
CM12	AB_BA2	
CM13	A2_BA0	
CM14	A3_BA3	
CM15	CS*	
CM16		CAS*
CM17		CKE*
CM18		RST*
CM19		RAS*
CM20		A1_A9
CM21		A0_A10
CM22		A12_RFU
CM23		AB*
CM24		AB_A11
CM25		AT_A8
CM26		WE*
CM27		AS_BA1
CM28		AB_BA2
CM29		A2_BA0
CM30		A3_BA3
CM31		CS*

**GALAXY** Galaxy Microsystems (HK) Ltd.

Page Name: GPU FB\_AB

Size: Custom Project Name: P45U Design By: Carson Rev: V10

Date: Thursday, December 28, 2017 Sheet 4 of 37

PROPERTY NOTE: This document contains information confidential and property to Galaxy Microsystems (HK) Ltd.

ALL NVIDIA DESIGN SPECIFICATIONS, REFERENCE SPECIFICATIONS, REFERENCE BOARDS, FILES, DRAWINGS, DIAGNOSTICS, LISTS AND OTHER DOCUMENTS OR INFORMATION (TOGETHER AND SEPARATELY, "MATERIALS") ARE BEING PROVIDED "AS IS". THE MATERIALS MAY CONTAIN KNOWN AND UNKNOWN VIOLATIONS OR DEVIATIONS OF INDUSTRY STANDARDS AND SPECIFICATIONS. NVIDIA MAKES NO WARRANTIES, EXPRESSED, IMPLIED, STATUTORY OR OTHERWISE WITH RESPECT TO THE MATERIALS OR OTHERWISE, AND EXPRESSLY DISCLAIMS ALL IMPLIED WARRANTIES INCLUDING, WITHOUT LIMITATION, THE WARRANTIES OF DESIGN, OF NON-INFRINGEMENT, MERCHANTABILITY OR FITNESS FOR A PARTICULAR PURPOSE, OR ARISING FROM A COURSE OF DEALING, TRADE USAGE, TRADE PRACTICE, OR INDUSTRY STANDARDS.

ASSEMBLY PAGE DETAIL	-ASSEMBLY_DESCRIPTION- GPU_FB_AB
----------------------	----------------------------------

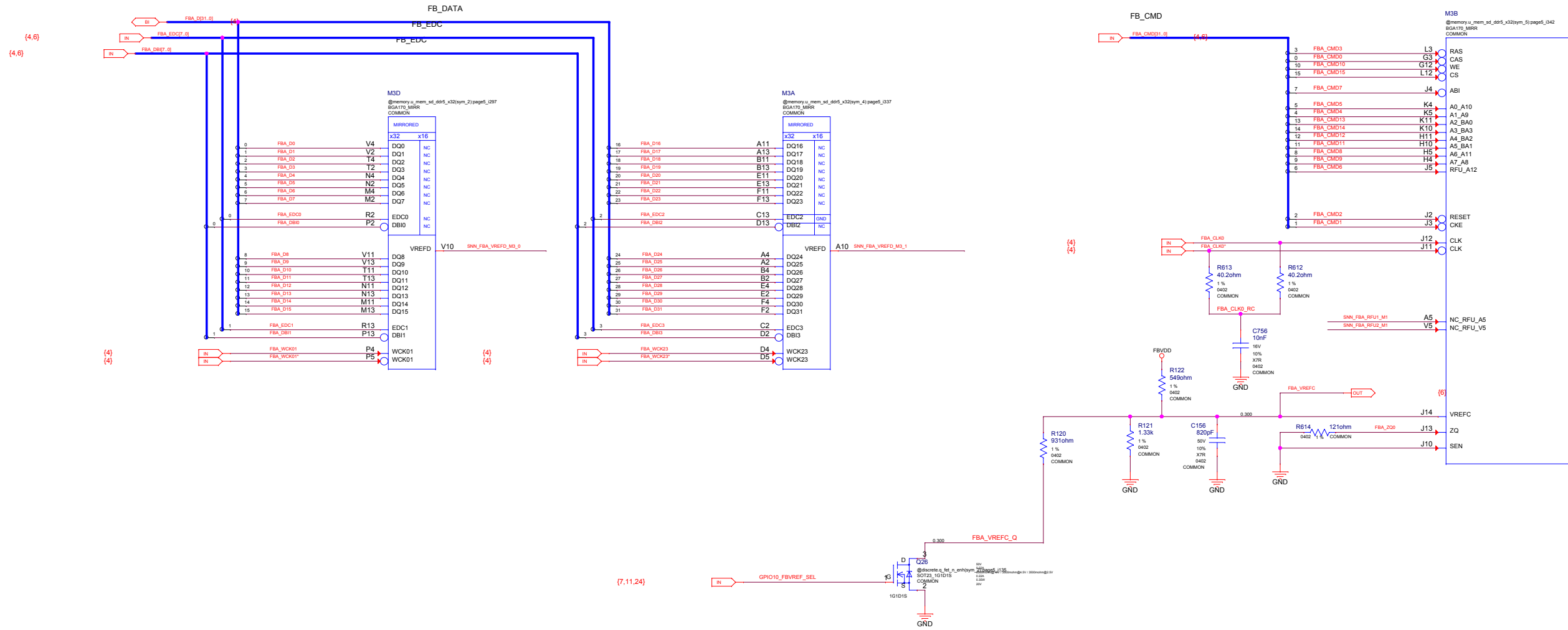

ALL NVIDIA DESIGN SPECIFICATIONS, REFERENCE SPECIFICATIONS, REFERENCE BOARDS, FILES, DRAWINGS, DIAGNOSTICS, LISTS AND OTHER DOCUMENTS OR INFORMATION (TOGETHER AND SEPARATELY, "MATERIALS") ARE BEING PROVIDED "AS IS". THE MATERIALS MAY CONTAIN KNOWN AND UNKNOWN VIOLATIONS OR DEVIATIONS OF INDUSTRY STANDARDS AND SPECIFICATIONS. NVIDIA MAKES NO WARRANTIES, EXPRESSED, IMPLIED, STATUTORY OR OTHERWISE WITH RESPECT TO THE MATERIALS OR OTHERWISE, AND EXPRESSLY DISCLAIMS ALL IMPLIED WARRANTIES INCLUDING, WITHOUT LIMITATION, THE WARRANTIES OF DESIGN, OF NON-INFRINGEMENT, MERCHANTABILITY OR FITNESS FOR A PARTICULAR PURPOSE, OR ARISING FROM A COURSE OF DEALING, TRADE USAGE, TRADE PRACTICE, OR INDUSTRY STANDARDS.

ASSEMBLY PAGE DETAIL	<ASSEMBLY_DESCRIPTION> MEMORY: FBA[31:0]
----------------------	---

**GALAXY** Galaxy Microsystems (HK) Ltd.

Page Name: MEMORY: FBA[31:0]

Size: Custom	Project Name: P45U	Design By: Carson	Rev: V10
Date: Thursday, December 28, 2017	Sheet: 5	of: 37	

PROPERTY NOTE: This document contains information confidential and property to Galaxy Microsystems (HK) Ltd.

(4,5)  
(4,5)

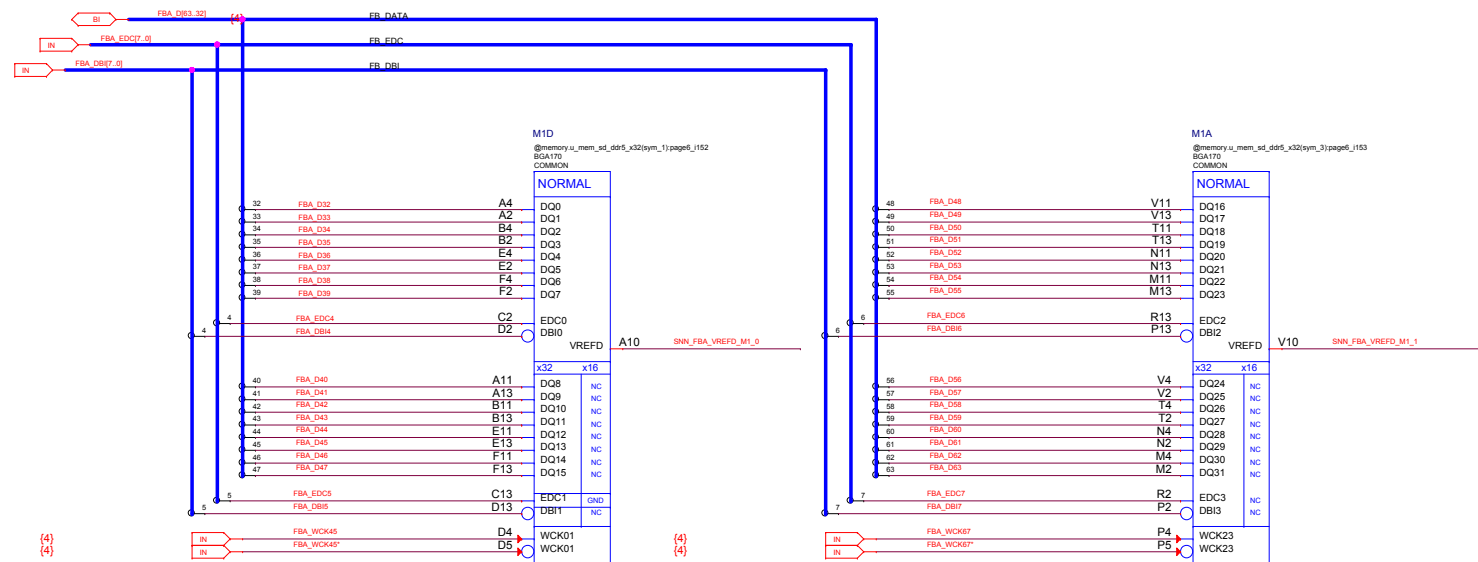

(4)  
(4)

(4)  
(4)

(4)  
(4)

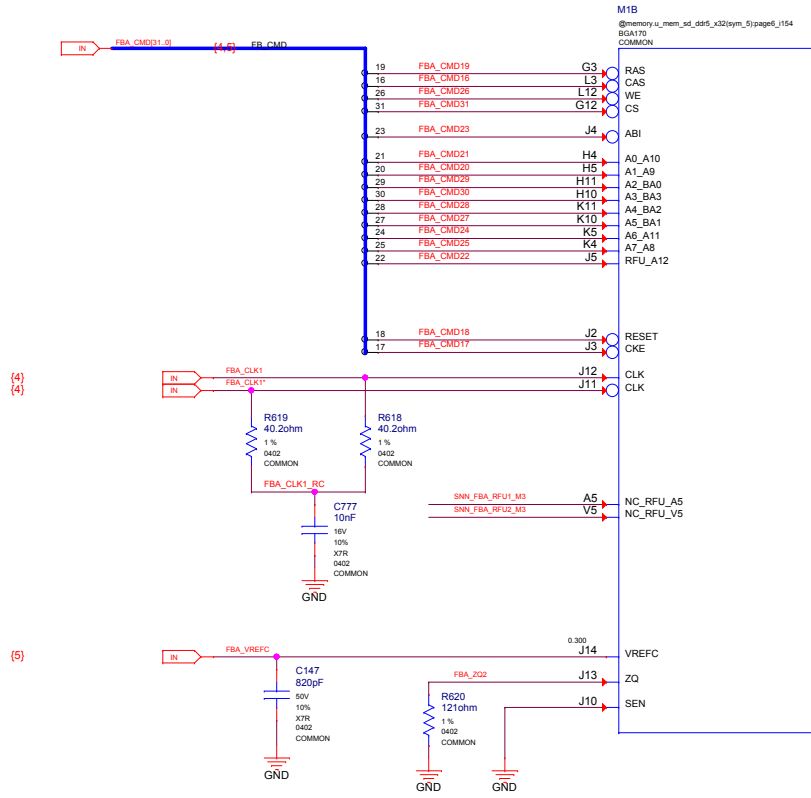

(4)  
(4)

(5)

ALL NVIDIA DESIGN SPECIFICATIONS, REFERENCE SPECIFICATIONS, REFERENCE BOARDS, FILES, DRAWINGS, DIAGNOSTICS, LISTS AND OTHER DOCUMENTS OR INFORMATION (TOGETHER AND SEPARATELY, 'MATERIALS') ARE BEING PROVIDED 'AS IS'. THE MATERIALS MAY CONTAIN KNOWN AND UNKNOWN VIOLATIONS OR DEVIATIONS OF INDUSTRY STANDARDS AND SPECIFICATIONS. NVIDIA MAKES NO WARRANTIES, EXPRESSED, IMPLIED, STATUTORY OR OTHERWISE WITH RESPECT TO THE MATERIALS OR OTHERWISE, AND EXPRESSLY DISCLAIMS ALL IMPLIED WARRANTIES INCLUDING, WITHOUT LIMITATION, THE WARRANTIES OF DESIGN, OF NONINFRINGEMENT, MERCHANTABILITY OR FITNESS FOR A PARTICULAR PURPOSE, OR ARISING FROM A COURSE OF DEALING, TRADE USAGE, TRADE PRACTICE, OR INDUSTRY STANDARDS.

ASSEMBLY PAGE DETAIL	-ASSEMBLY_DESCRIPTION- MEMORY: FBA[63:32]
----------------------	--

**GALAXY** Galaxy Microsystems (HK) Ltd.

Page Name: MEMORY: FBA[63:32]

Size: Custom	Project Name: P45U	Design By: Carson	Rev: V10
Date: Thursday, December 28, 2017	Sheet: 6	of: 37	

PROPERTY NOTE: This document contains information confidential and property to Galaxy Microsystems (HK) Ltd.

(4,8)  
(4,8)

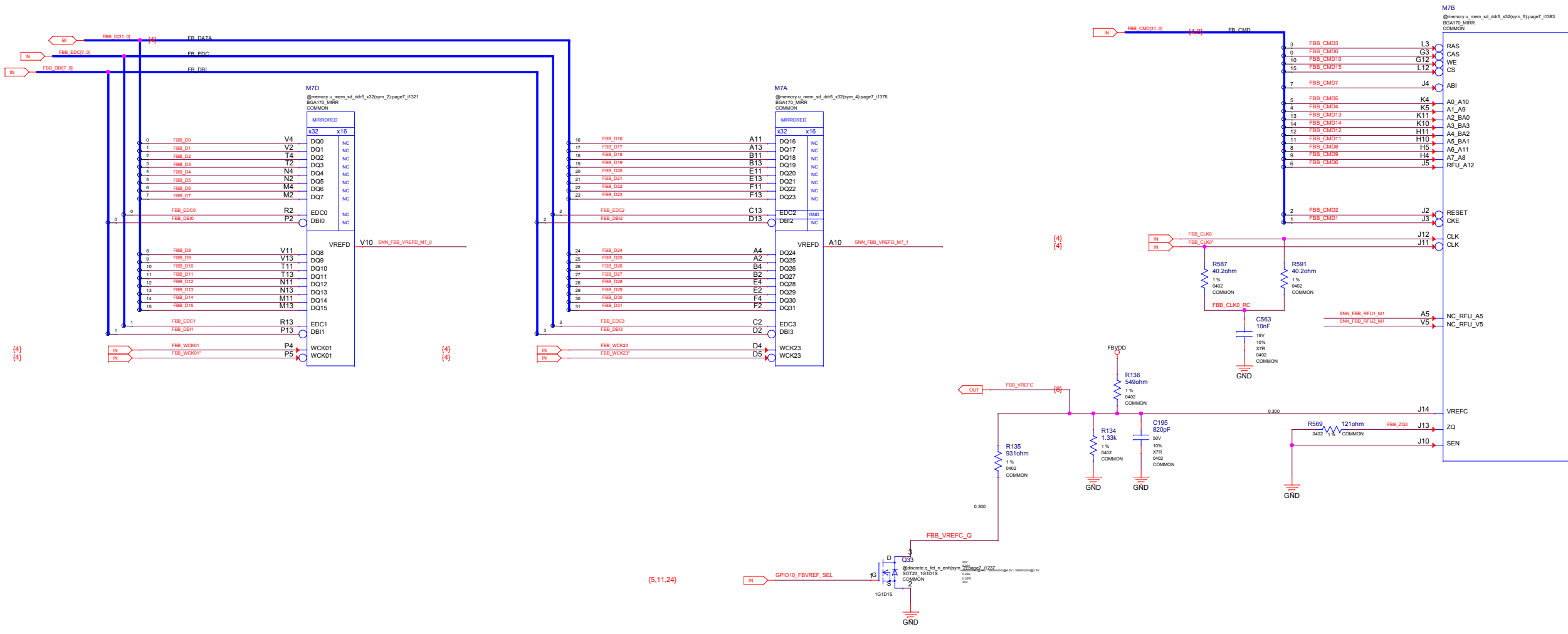

(5,11,24)

ALL NVIDIA DESIGN SPECIFICATIONS, REFERENCE SPECIFICATIONS, REFERENCE BOARDS, FILES, DRAWINGS, DIAGNOSTICS, LISTS AND OTHER DOCUMENTS OR INFORMATION (TOGETHER AND SEPARATELY, 'MATERIALS') ARE BEING PROVIDED 'AS IS'. THE MATERIALS MAY CONTAIN KNOWN AND UNKNOWN VIOLATIONS OR DEVIATIONS OF INDUSTRY STANDARDS AND SPECIFICATIONS. NVIDIA MAKES NO WARRANTIES, EXPRESSED, IMPLIED, STATUTORY OR OTHERWISE WITH RESPECT TO THE MATERIALS OR OTHERWISE, AND EXPRESSLY DISCLAIMS ALL IMPLIED WARRANTIES INCLUDING, WITHOUT LIMITATION, THE WARRANTIES OF DESIGN, OF NON-INFRINGEMENT, MERCHANTABILITY OR FITNESS FOR A PARTICULAR PURPOSE, OR ARISING FROM A COURSE OF DEALING, TRADE USAGE, TRADE PRACTICE, OR INDUSTRY STANDARDS.

ASSEMBLY PAGE DETAIL	-ASSEMBLY_DESCRIPTION- MEMORY: FBB[31:0]
----------------------	---

**GALAXY** Galaxy Microsystems (HK) Ltd.

Page Name: MEMORY: FBB[31:0]

Size: Custom	Project Name: P45U	Design By: Carson	Rev: V10
Date: Thursday, December 28, 2017	Sheet: 7	of: 37	

PROPERTY NOTE: This document contains information confidential and property to Galaxy Microsystems (HK) Ltd.

(4,7)

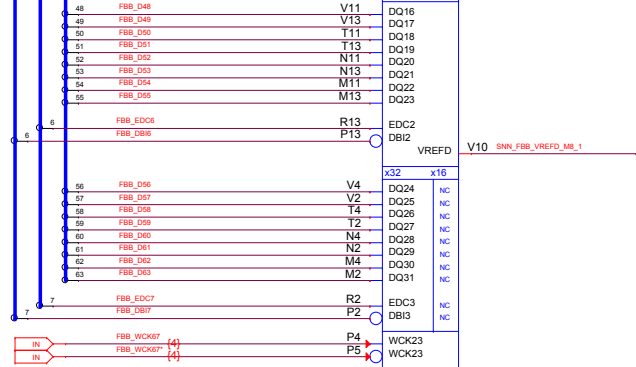
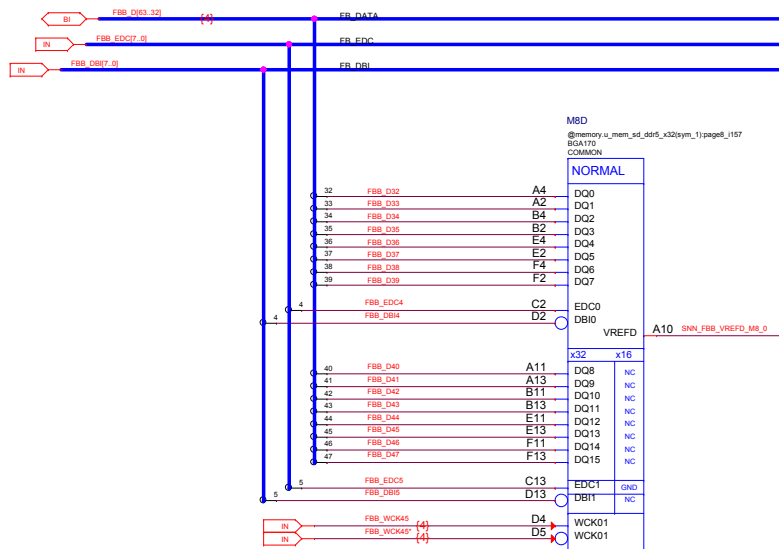

(4)

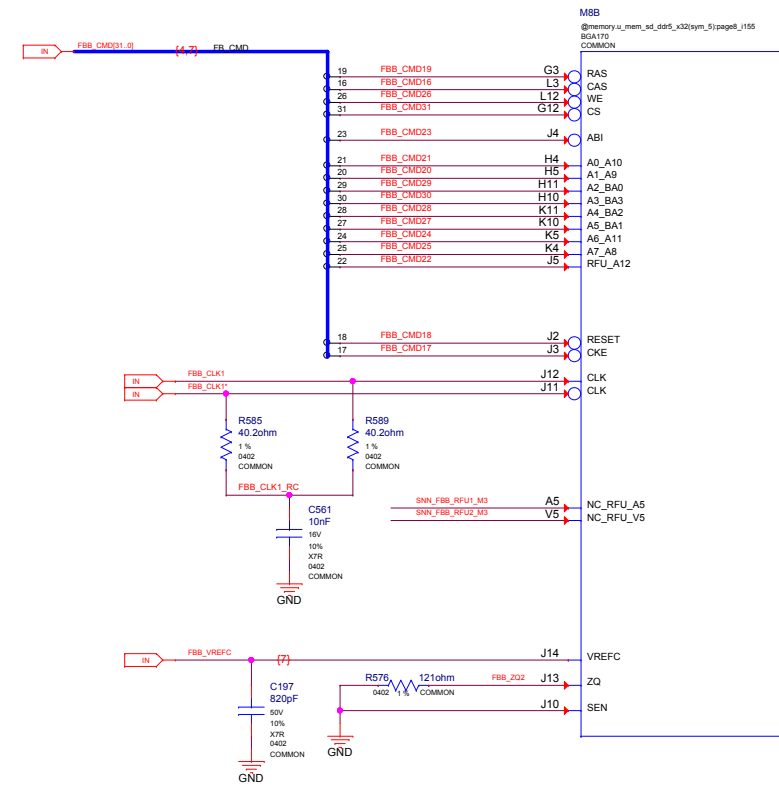

**GALAXY** Galaxy Microsystems (HK) Ltd.

Page Name: MEMORY: FBB[63:32]

Size: Custom	Project Name: P45U	Design By: Carson	Rev: V10
Date: Thursday, December 28, 2017	Sheet: 8	of: 37	

PROPERTY NOTE: This document contains information confidential and property to Galaxy Microsystems (HK) Ltd.

ALL NVIDIA DESIGN SPECIFICATIONS, REFERENCE SPECIFICATIONS, REFERENCE BOARDS, FILES, DRAWINGS, DIAGNOSTICS, LISTS AND OTHER DOCUMENTS OR INFORMATION (TOGETHER AND SEPARATELY, 'MATERIALS') ARE BEING PROVIDED 'AS IS'. THE MATERIALS MAY CONTAIN KNOWN AND UNKNOWN VIOLATIONS OR DEVIATIONS OF INDUSTRY STANDARDS AND SPECIFICATIONS. NVIDIA MAKES NO WARRANTIES, EXPRESSED, IMPLIED, STATUTORY OR OTHERWISE WITH RESPECT TO THE MATERIALS OR OTHERWISE, AND EXPRESSLY DISCLAIMS ALL IMPLIED WARRANTIES INCLUDING, WITHOUT LIMITATION, THE WARRANTIES OF DESIGN, OF NONINFRINGEMENT, MERCHANTABILITY OR FITNESS FOR A PARTICULAR PURPOSE, OR ARISING FROM A COURSE OF DEALING, TRADE USAGE, TRADE PRACTICE, OR INDUSTRY STANDARDS.

ASSEMBLY PAGE DETAIL	-ASSEMBLY_DESCRIPTION- MEMORY: FBB[63:32]
----------------------	---



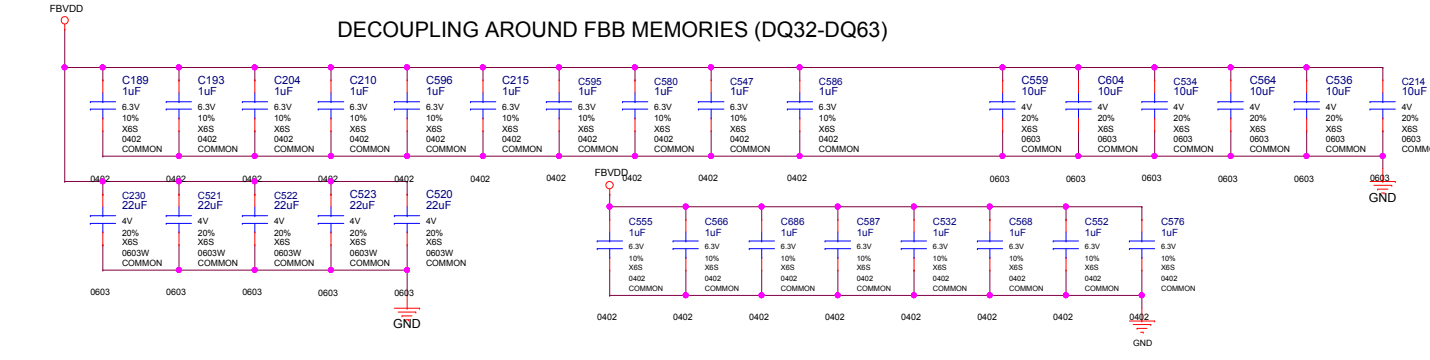
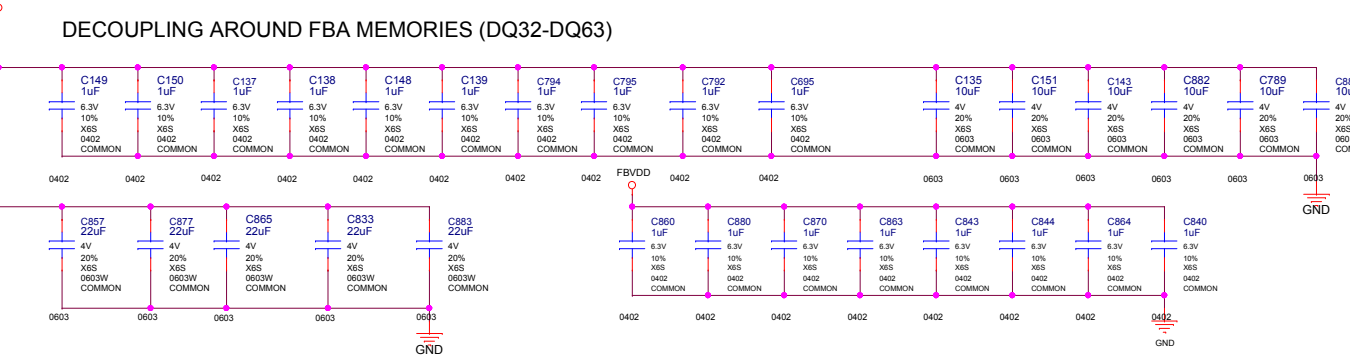
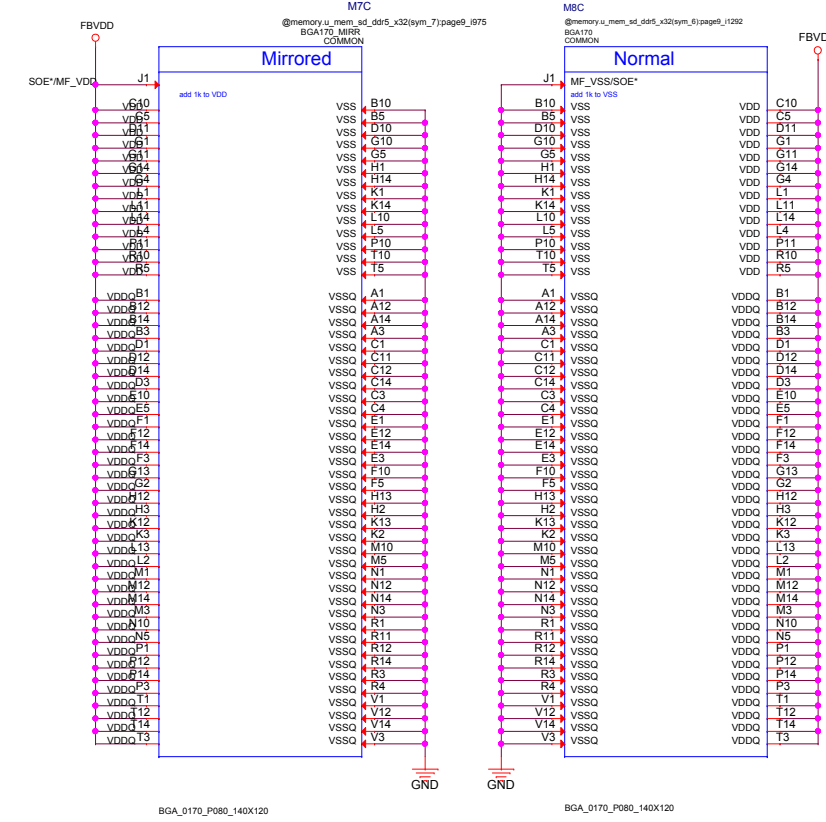
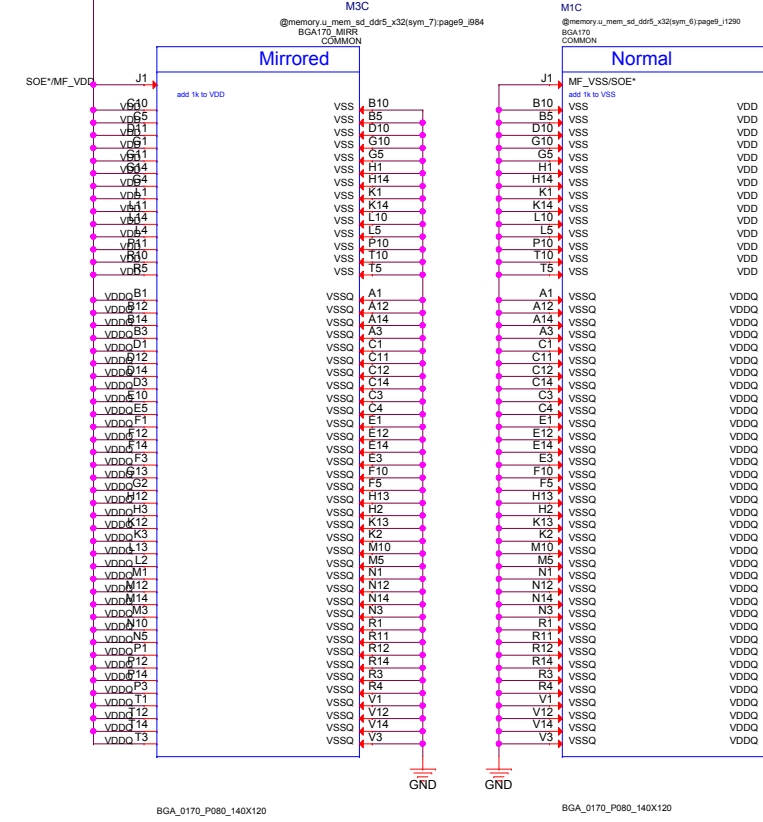
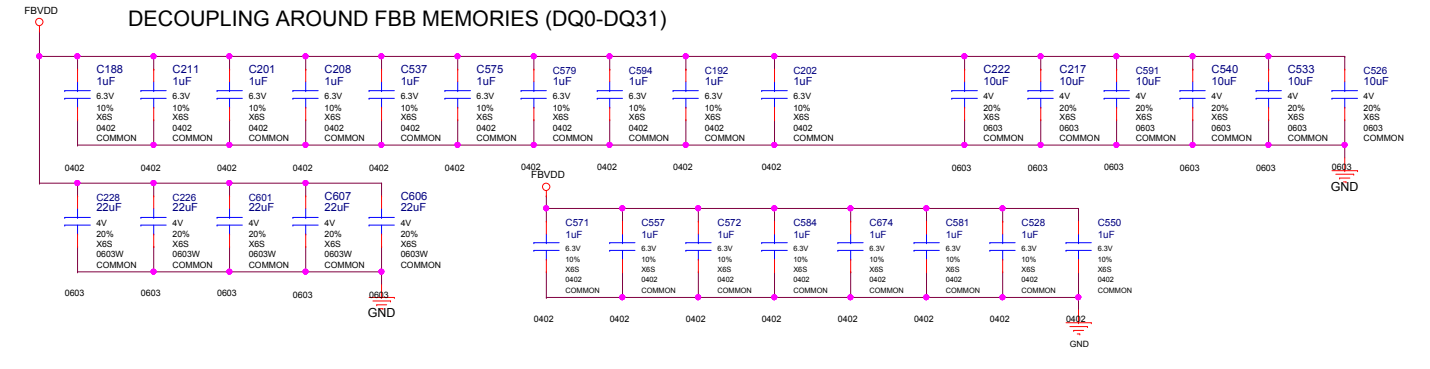
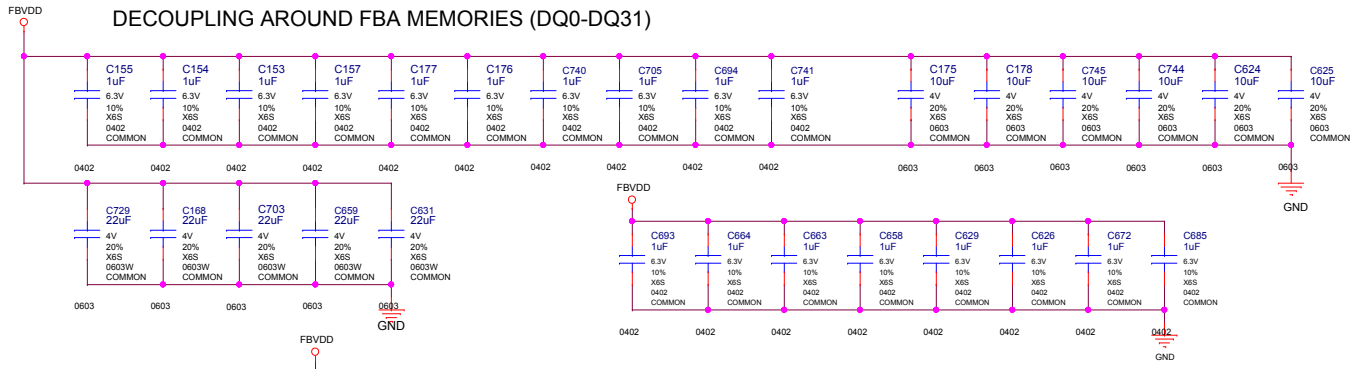

ALL NVIDIA DESIGN SPECIFICATIONS, REFERENCE SPECIFICATIONS, REFERENCE BOARDS, FILES, DRAWINGS, DIAGNOSTICS, LISTS AND OTHER DOCUMENTS OR INFORMATION (TOGETHER AND SEPARATELY, "MATERIALS") ARE BEING PROVIDED "AS IS". THE MATERIALS MAY CONTAIN KNOWN AND UNKNOWN VIOLATIONS OR DEVIATIONS OF INDUSTRY STANDARDS AND SPECIFICATIONS. NVIDIA MAKES NO WARRANTIES, EXPRESSED, IMPLIED, STATUTORY OR OTHERWISE WITH RESPECT TO THE MATERIALS OR OTHERWISE, AND EXPRESSLY DISCLAIMS ALL IMPLIED WARRANTIES INCLUDING, WITHOUT LIMITATION, THE WARRANTIES OF DESIGN, OF NONINFRINGEMENT, MERCHANTABILITY OR FITNESS FOR A PARTICULAR PURPOSE, OR ARISING FROM A COURSE OF DEALING, TRADE USAGE, TRADE PRACTICE, OR INDUSTRY STANDARDS.

ASSEMBLY PAGE DETAIL	<ASSEMBLY_DESCRIPTION> MEM_FB_AB_PWR
----------------------	--------------------------------------

**GALAXY** Galaxy Microsystems (HK) Ltd.

Page Name: MEM\_FB\_AB\_PWR

Size: Custom	Project Name: P45U	Design By: Carson	Rev: V10
--------------	--------------------	-------------------	----------

Date: Thursday, December 28, 2017 Sheet 9 of 37

PROPERTY NOTE: This document contains information confidential and property to Galaxy Microsystems (HK) Ltd.

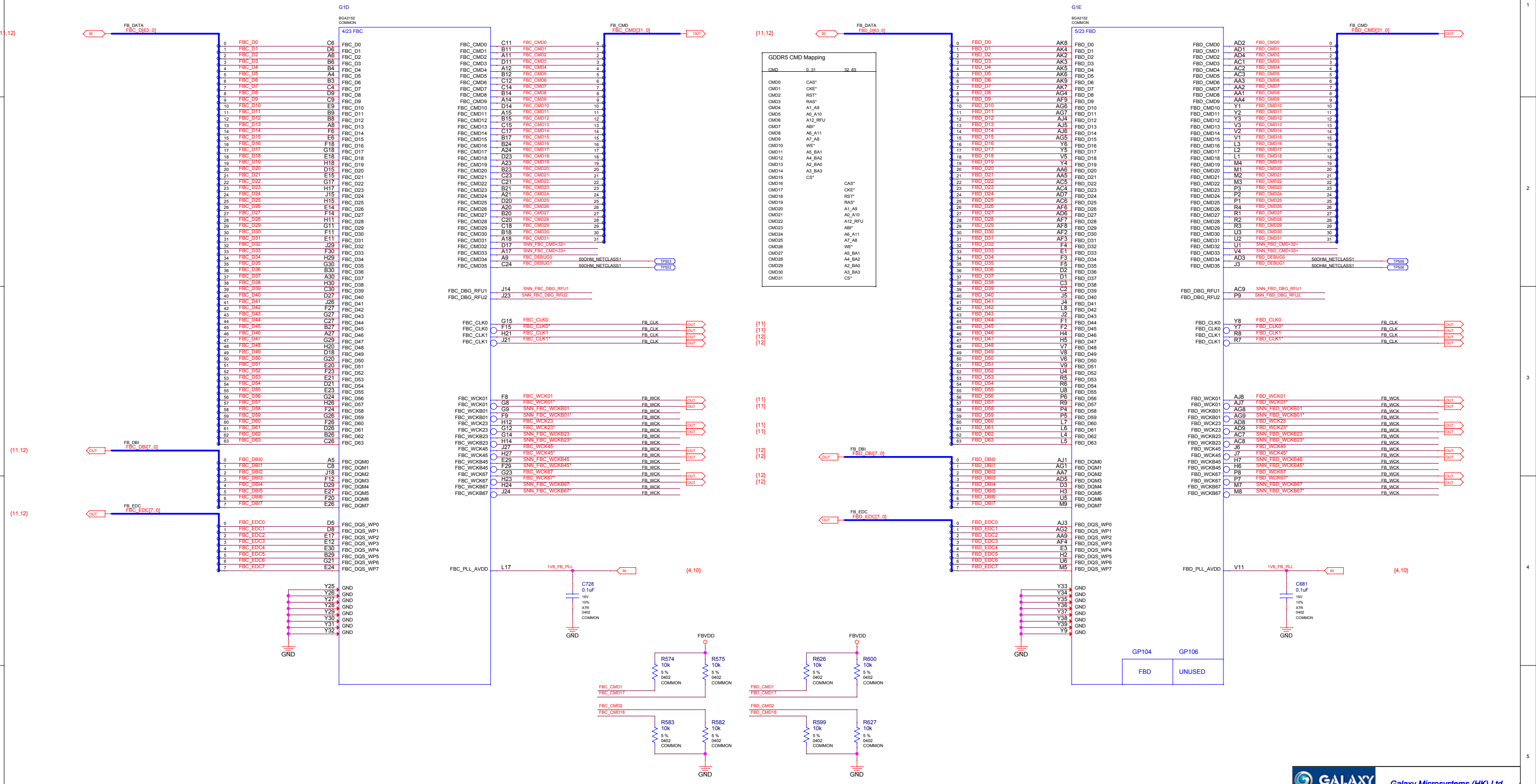

ALL NVIDIA DESIGN SPECIFICATIONS, REFERENCE SPECIFICATIONS, REFERENCE BOARDS, FILES, DRAWINGS, DIAGNOSTICS, LISTS AND OTHER DOCUMENTS OR INFORMATION (TOGETHER AND SEPARATELY, "MATERIALS") ARE BEING PROVIDED "AS IS". THE MATERIALS MAY CONTAIN KNOWN AND UNKNOWN VIOLATIONS OR DEVIATIONS OF INDUSTRY STANDARDS AND SPECIFICATIONS. NVIDIA MAKES NO WARRANTIES, EXPRESSED, IMPLIED, STATUTORY OR OTHERWISE WITH RESPECT TO THE MATERIALS OR OTHERWISE, AND EXPRESSLY DISCLAIMS ALL IMPLIED WARRANTIES INCLUDING, WITHOUT LIMITATION, THE WARRANTIES OF DESIGN, OF NONINFRINGEMENT, MERCHANTABILITY OR FITNESS FOR A PARTICULAR PURPOSE, OR ARISING FROM A COURSE OF DEALING, TRADE USAGE, TRADE PRACTICE, OR INDUSTRY STANDARDS.

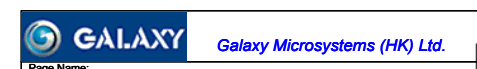

(10,12)  
(10,12)

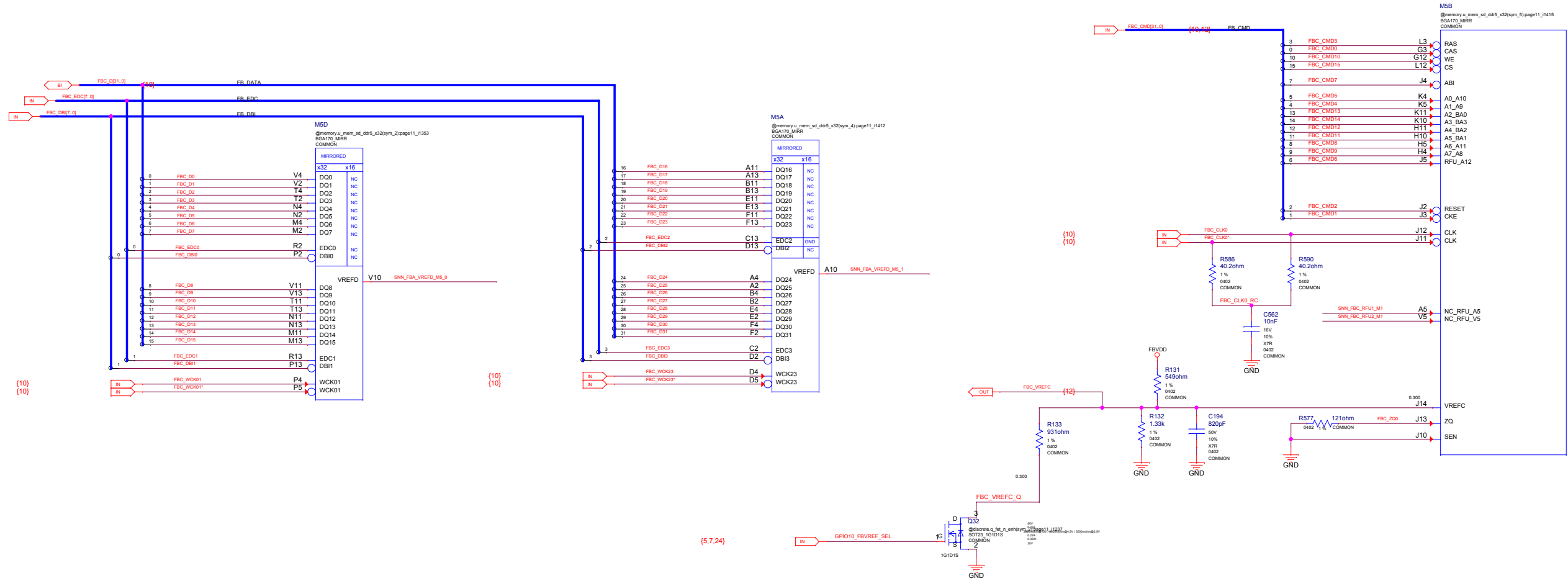

(10)  
(10)

(10)  
(10)

(10)  
(10)

(5.7.24)

ALL NVIDIA DESIGN SPECIFICATIONS, REFERENCE SPECIFICATIONS, REFERENCE BOARDS, FILES, DRAWINGS, DIAGNOSTICS, LISTS AND OTHER DOCUMENTS OR INFORMATION (TOGETHER AND SEPARATELY, 'MATERIALS') ARE BEING PROVIDED 'AS IS'. THE MATERIALS MAY CONTAIN KNOWN AND UNKNOWN VIOLATIONS OR DEVIATIONS OF INDUSTRY STANDARDS AND SPECIFICATIONS. NVIDIA MAKES NO WARRANTIES, EXPRESSED, IMPLIED, STATUTORY OR OTHERWISE WITH RESPECT TO THE MATERIALS OR OTHERWISE, AND EXPRESSLY DISCLAIMS ALL IMPLIED WARRANTIES INCLUDING, WITHOUT LIMITATION, THE WARRANTIES OF DESIGN, OF NONINFRINGEMENT, MERCHANTABILITY OR FITNESS FOR A PARTICULAR PURPOSE, OR ARISING FROM A COURSE OF DEALING, TRADE USAGE, TRADE PRACTICE, OR INDUSTRY STANDARDS.

ASSEMBLY PAGE DETAIL	<ASSEMBLY_DESCRIPTION> MEMORY: FBC[31:0]
----------------------	---

**GALAXY** Galaxy Microsystems (HK) Ltd.

Page Name: MEMORY: FBC[31:0]

Size: Custom	Project Name: P45U	Design By: Carson	Rev: V10
Date: Thursday, December 28, 2017	Sheet: 11	of: 37	

PROPERTY NOTE: This document contains information confidential and property to Galaxy Microsystems (HK) Ltd.

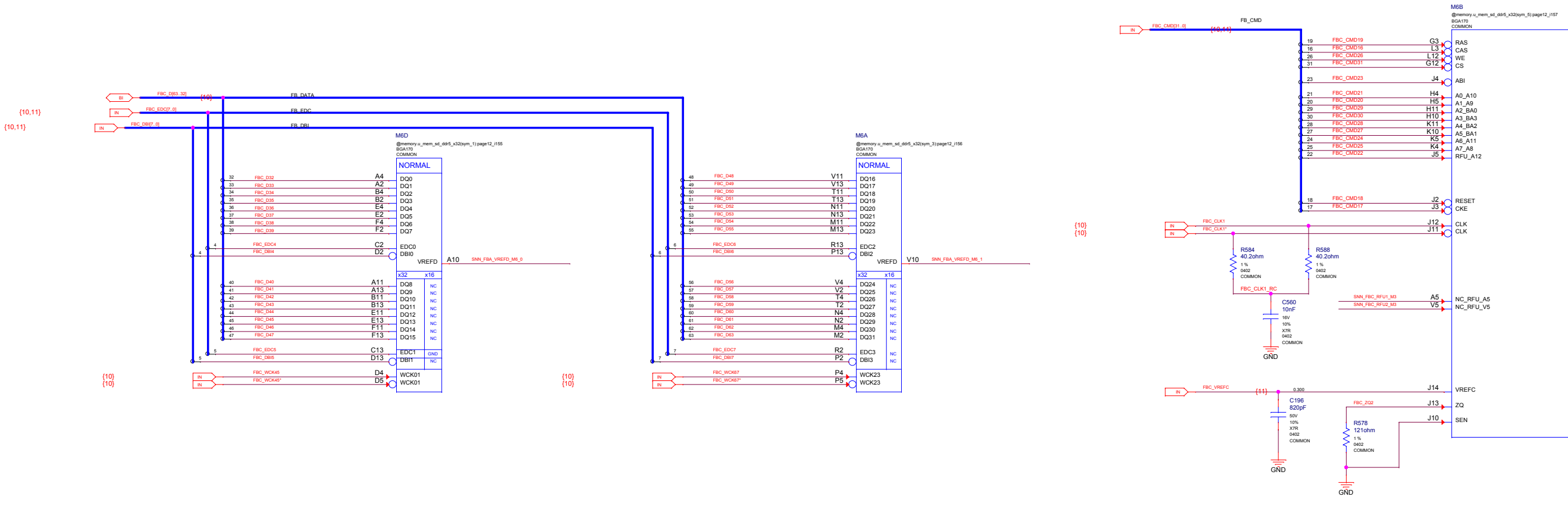

ALL NVIDIA DESIGN SPECIFICATIONS, REFERENCE SPECIFICATIONS, REFERENCE BOARDS, FILES, DRAWINGS, DIAGNOSTICS, LISTS AND OTHER DOCUMENTS OR INFORMATION (TOGETHER AND SEPARATELY, "MATERIALS") ARE BEING PROVIDED "AS IS". THE MATERIALS MAY CONTAIN KNOWN AND UNKNOWN VIOLATIONS OR DEVIATIONS OF INDUSTRY STANDARDS AND SPECIFICATIONS. NVIDIA MAKES NO WARRANTIES, EXPRESSED, IMPLIED, STATUTORY OR OTHERWISE WITH RESPECT TO THE MATERIALS OR OTHERWISE, AND EXPRESSLY DISCLAIMS ALL IMPLIED WARRANTIES INCLUDING, WITHOUT LIMITATION, THE WARRANTIES OF DESIGN, OF NONINFRINGEMENT, MERCHANTABILITY OR FITNESS FOR A PARTICULAR PURPOSE, OR ARISING FROM A COURSE OF DEALING, TRADE USAGE, TRADE PRACTICE, OR INDUSTRY STANDARDS.

ASSEMBLY PAGE DETAIL	<ASSEMBLY_DESCRIPTION> MEMORY: FBC[63:32]
----------------------	--

**GALAXY** Galaxy Microsystems (HK) Ltd.

Page Name: MEMORY: FBC[63:32]

Size: Custom	Project Name: P45U	Design By: Carson	Rev: V10
Date: Thursday, December 28, 2017	Sheet: 12	of: 37	

PROPERTY NOTE: This document contains information confidential and property to Galaxy Microsystems (HK) Ltd.

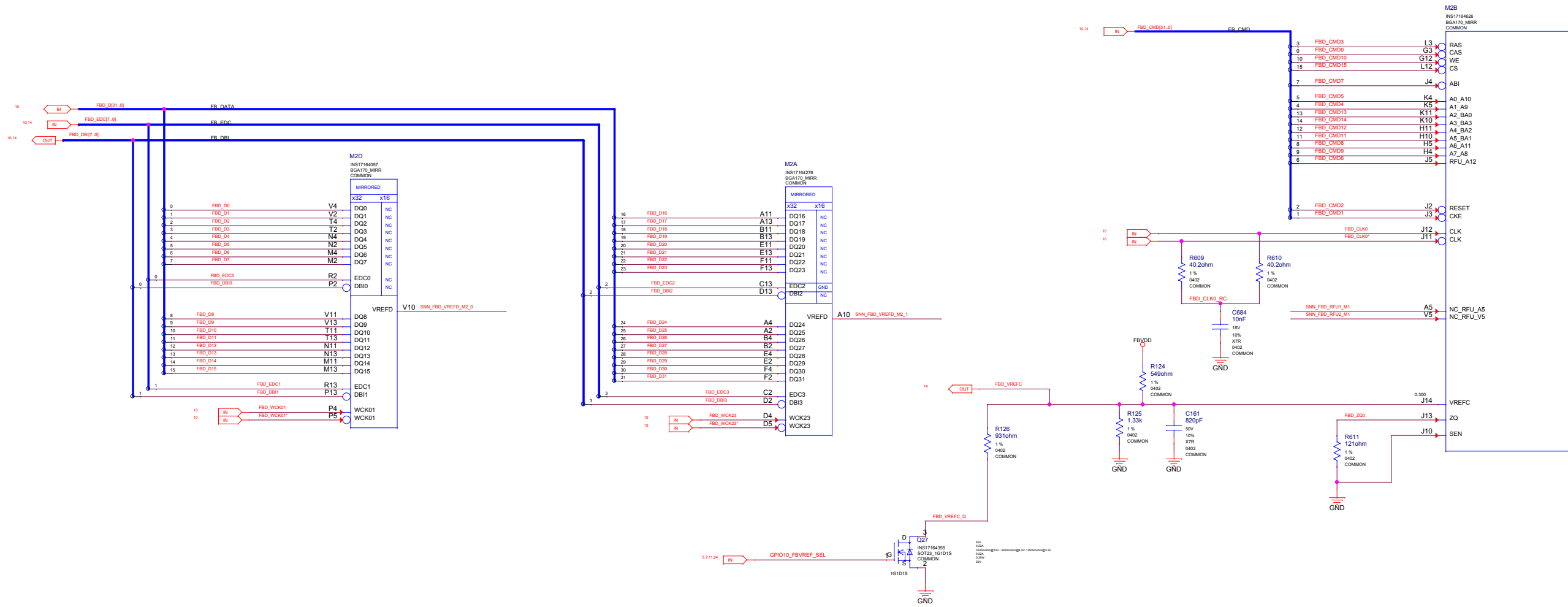

ALL NVIDIA DESIGN SPECIFICATIONS, REFERENCE SPECIFICATIONS, REFERENCE BOARDS, FILES, DRAWINGS, DIAGNOSTICS, LISTS AND OTHER DOCUMENTS OR INFORMATION (TOGETHER AND SEPARATELY, "MATERIALS") ARE BEING PROVIDED "AS IS". THE MATERIALS MAY CONTAIN KNOWN AND UNKNOWN VIOLATIONS OR DEVIATIONS OF INDUSTRY STANDARDS AND SPECIFICATIONS. NVIDIA MAKES NO WARRANTIES, EXPRESSED, IMPLIED, STATUTORY OR OTHERWISE WITH RESPECT TO THE MATERIALS OR OTHERWISE, AND EXPRESSLY DISCLAIMS ALL IMPLIED WARRANTIES INCLUDING, WITHOUT LIMITATION, THE WARRANTIES OF DESIGN, OF NONINFRINGEMENT, MERCHANTABILITY OR FITNESS FOR A PARTICULAR PURPOSE, OR ARISING FROM A COURSE OF DEALING, TRADE USAGE, TRADE PRACTICE, OR INDUSTRY STANDARDS.

ASSEMBLY PAGE DETAIL	<ASSEMBLY_DESCRIPTION> MEMORY: FBD[31:0]
----------------------	---

**GALAXY** Galaxy Microsystems (HK) Ltd.

Page Name: MEMORY: FBD[31:0]

Size: Custom	Project Name: P45U	Design By: Carson	Rev: V10
Date: Thursday, December 28, 2017	Sheet: 13	of: 37	

PROPERTY NOTE: This document contains information confidential and property to Galaxy Microsystems (HK) Ltd.

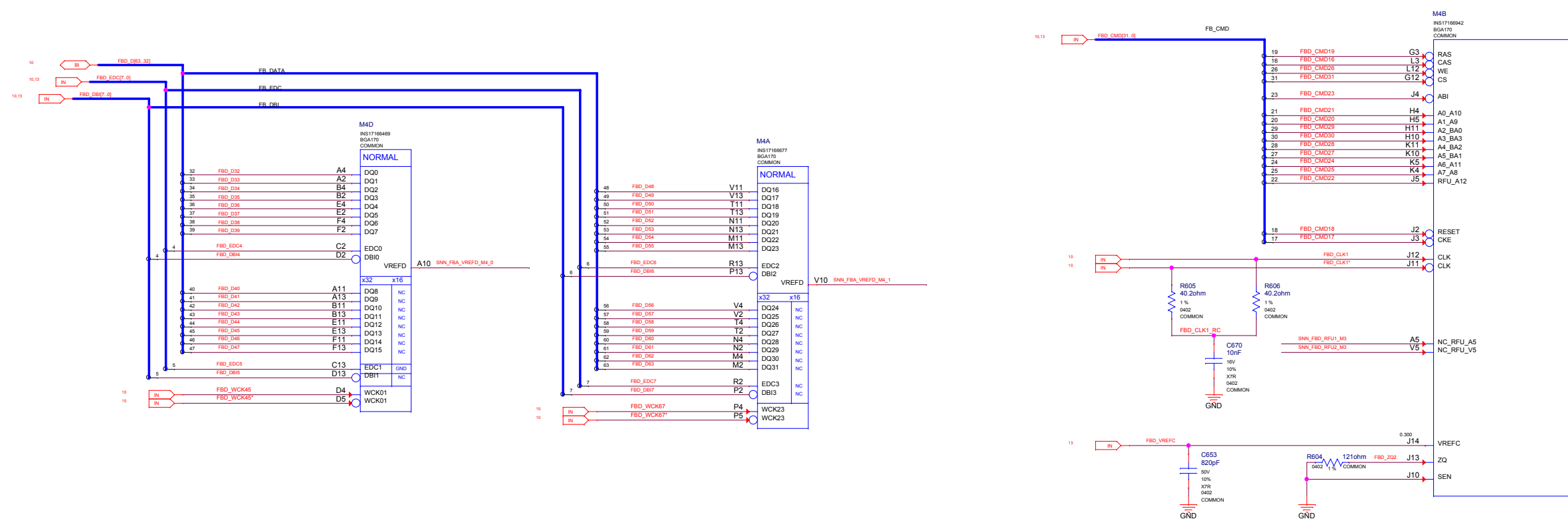

ALL NVIDIA DESIGN SPECIFICATIONS, REFERENCE SPECIFICATIONS, REFERENCE BOARDS, FILES, DRAWINGS, DIAGNOSTICS, LISTS AND OTHER DOCUMENTS OR INFORMATION (TOGETHER AND SEPARATELY, 'MATERIALS') ARE BEING PROVIDED 'AS IS'. THE MATERIALS MAY CONTAIN KNOWN AND UNKNOWN VIOLATIONS OR DEVIATIONS OF INDUSTRY STANDARDS AND SPECIFICATIONS. NVIDIA MAKES NO WARRANTIES, EXPRESSED, IMPLIED, STATUTORY OR OTHERWISE WITH RESPECT TO THE MATERIALS OR OTHERWISE, AND EXPRESSLY DISCLAIMS ALL IMPLIED WARRANTIES INCLUDING, WITHOUT LIMITATION, THE WARRANTIES OF DESIGN, OF NONINFRINGEMENT, MERCHANTABILITY OR FITNESS FOR A PARTICULAR PURPOSE, OR ARISING FROM A COURSE OF DEALING, TRADE USAGE, TRADE PRACTICE, OR INDUSTRY STANDARDS.

ASSEMBLY PAGE DETAIL	<ASSEMBLY_DESCRIPTION> MEMORY: FBD[63:32]
----------------------	--

**GALAXY** Galaxy Microsystems (HK) Ltd.

Page Name: MEMORY: FBD[63:32]

Size: Custom	Project Name: P45U	Design By: Carson	Rev: V10
Date: Thursday, December 28, 2017	Sheet: 14	of: 37	

PROPERTY NOTE: This document contains information confidential and property to Galaxy Microsystems (HK) Ltd.

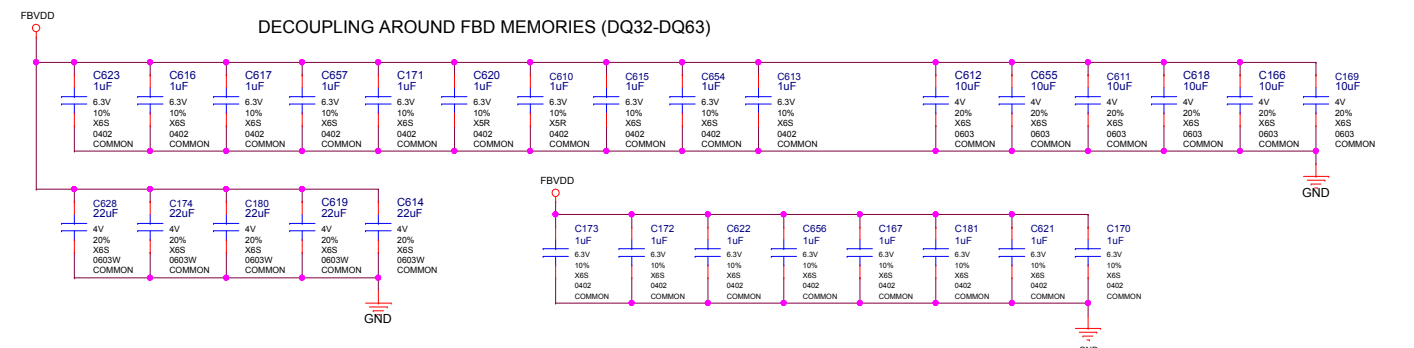
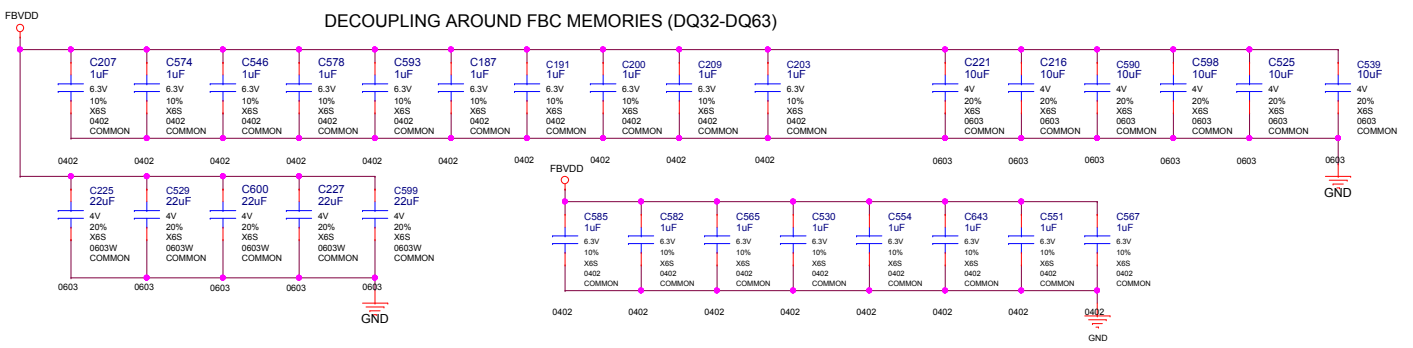
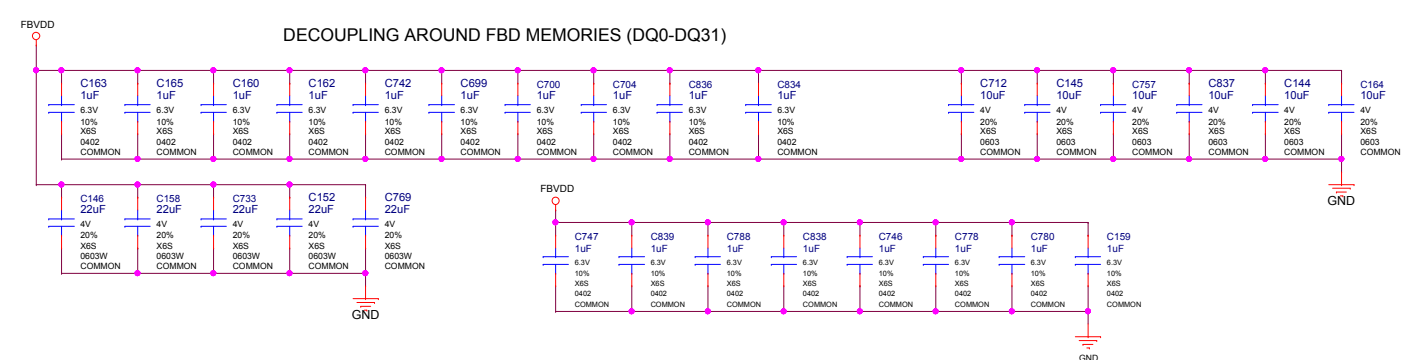
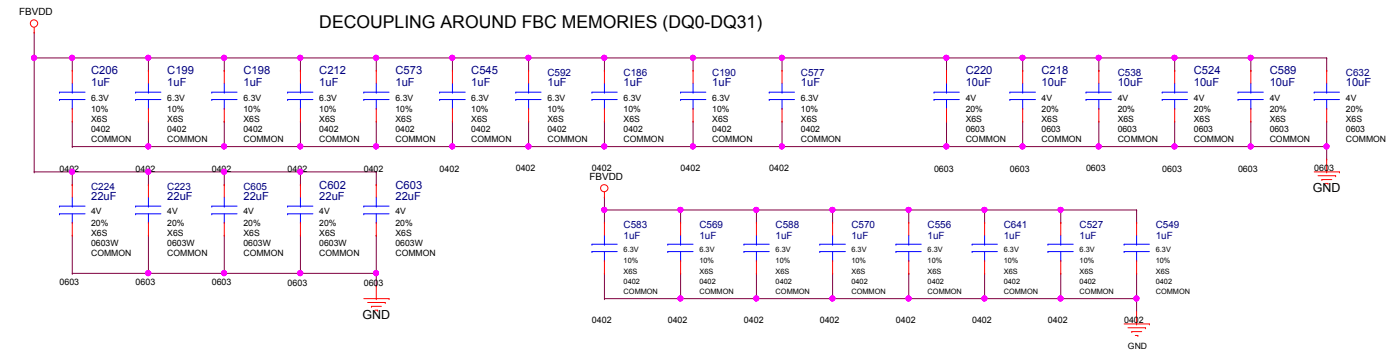

ALL NVIDIA DESIGN SPECIFICATIONS, REFERENCE SPECIFICATIONS, REFERENCE BOARDS, FILES, DRAWINGS, DIAGNOSTICS, LISTS AND OTHER DOCUMENTS OR INFORMATION (TOGETHER AND SEPARATELY, "MATERIALS") ARE BEING PROVIDED "AS IS". THE MATERIALS MAY CONTAIN KNOWN AND UNKNOWN VIOLATIONS OR DEVIATIONS OF INDUSTRY STANDARDS AND SPECIFICATIONS. NVIDIA MAKES NO WARRANTIES, EXPRESSED, IMPLIED, STATUTORY OR OTHERWISE WITH RESPECT TO THE MATERIALS OR OTHERWISE, AND EXPRESSLY DISCLAIMS ALL IMPLIED WARRANTIES INCLUDING, WITHOUT LIMITATION, THE WARRANTIES OF DESIGN, OF NONINFRINGEMENT, MERCHANTABILITY OR FITNESS FOR A PARTICULAR PURPOSE, OR ARISING FROM A COURSE OF DEALING, TRADE USAGE, TRADE PRACTICE, OR INDUSTRY STANDARDS.

ASSEMBLY PAGE DETAIL	-ASSEMBLY DESCRIPTION- MEM_FB_CD_PWR
----------------------	--------------------------------------

**GALAXY** Galaxy Microsystems (HK) Ltd.

Page Name: MEM\_FB\_CD\_PWR

Size: Custom	Project Name: P45U	Design By: Carson	Rev: V10
Date: Thursday, December 28, 2017	Sheet 15 of 37		

PROPERTY NOTE: This document contains information confidential and property to Galaxy Microsystems (HK) Ltd.

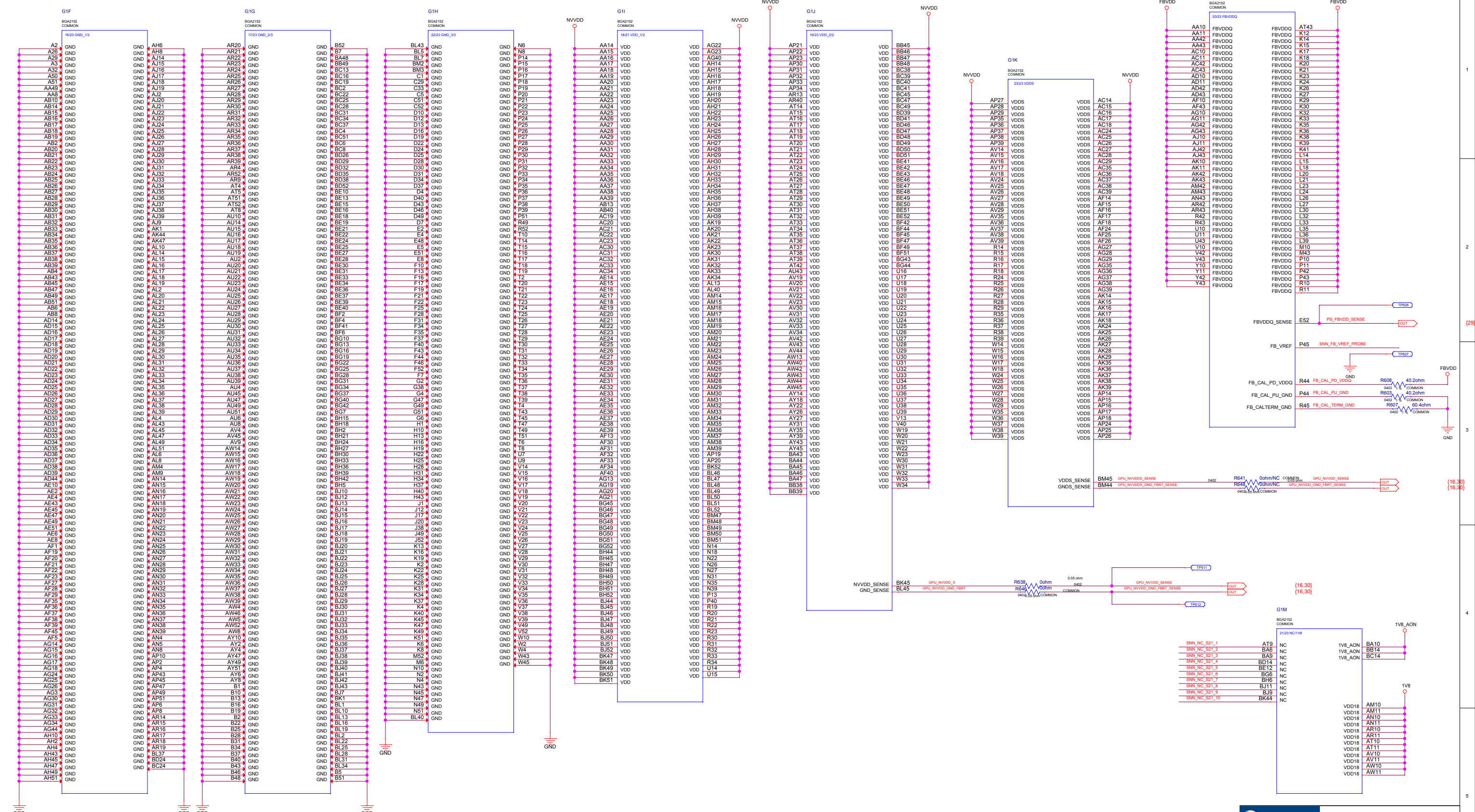

ALL NVIDIA DESIGN SPECIFICATIONS, REFERENCE SPECIFICATIONS, REFERENCE BOARDS, FILES, DRAWINGS, DIAGNOSTICS, LISTS AND OTHER DOCUMENTS (TOGETHER AND SEPARATELY, "MATERIALS") ARE BEING PROVIDED "AS IS". THE MATERIALS MAY CONTAIN KNOWN AND UNKNOWN VIOLATIONS OR DEVIATIONS OF INDUSTRY STANDARDS AND SPECIFICATIONS. NVIDIA MAKES NO WARRANTIES, EXPRESSED, IMPLIED, STATUTORY OR OTHERWISE WITH RESPECT TO THE MATERIALS OR OTHERWISE, AND EXPRESSLY DISCLAIMS ALL IMPLIED WARRANTIES INCLUDING, WITHOUT LIMITATION, THE WARRANTIES OF DESIGN, OF NONINFRINGEMENT, MERCHANTABILITY OR FITNESS FOR A PARTICULAR PURPOSE, OR ARISING FROM A COURSE OF DEALING, TRADE USAGE, TRADE PRACTICE, OR INDUSTRY STANDARDS.

ASSEMBLY PAGE DETAIL	<ASSEMBLY_DESCRIPTION> GPU PWR & GND
----------------------	--------------------------------------

**GALAXY** Galaxy Microsystems (HK) Ltd.

Page Name: GPU PWR & GND

Size: Custom	Project Name: P45U	Design By: Carson	Rev: V10
Date: Thursday, December 28, 2017	Sheet: 16	of 37	

PROPERTY NOTE: This document contains information confidential and property to Galaxy Microsystems (HK) Ltd.



FBVDD

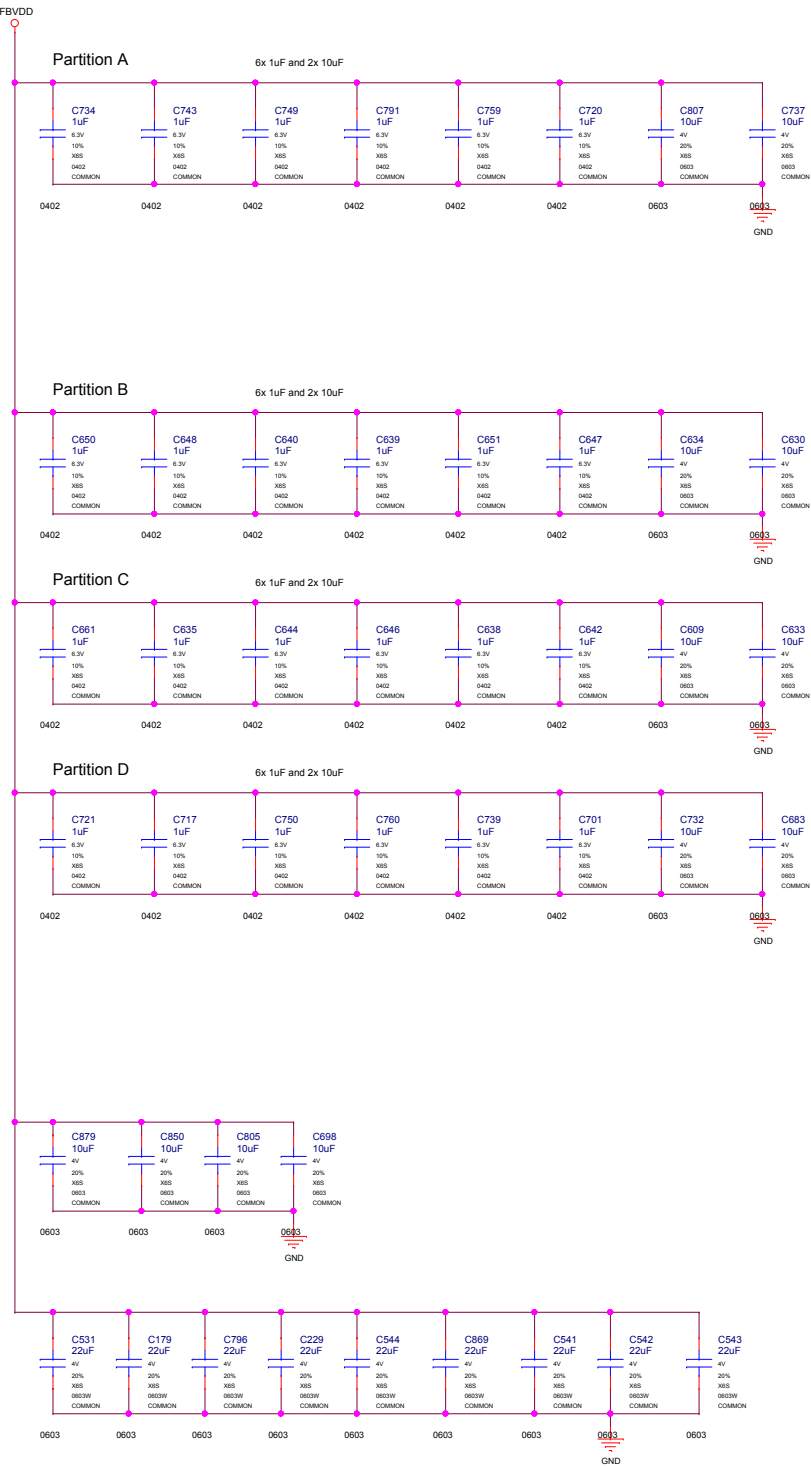

NVVD

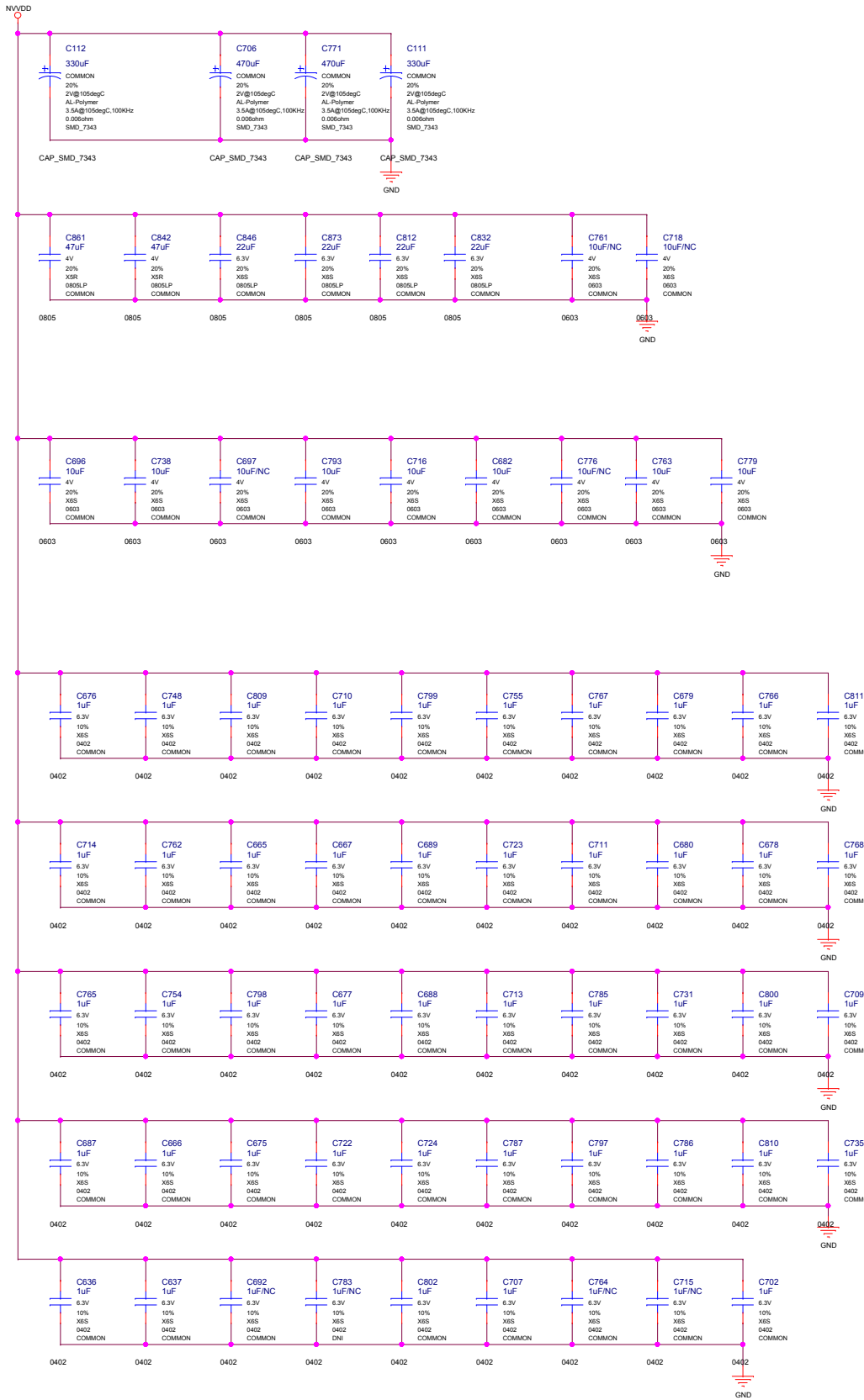

NVVD

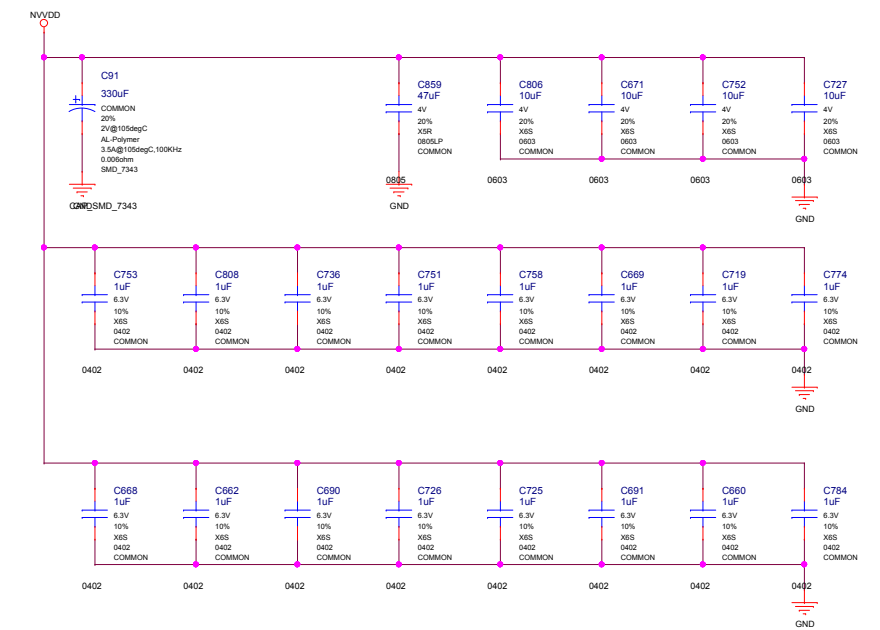

1V8\_AON

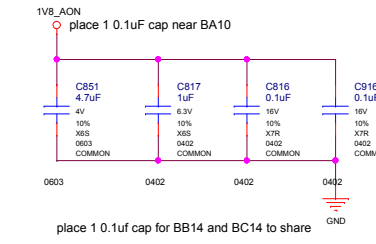

1V8\_MAIN

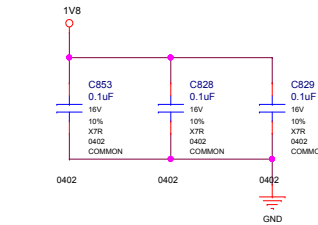

ALL NVIDIA DESIGN SPECIFICATIONS, REFERENCE SPECIFICATIONS, REFERENCE BOARDS, FILES, DRAWINGS, DIAGNOSTICS, LISTS AND OTHER DOCUMENTS OR INFORMATION (TOGETHER AND SEPARATELY, "MATERIALS") ARE BEING PROVIDED "AS IS". THE MATERIALS MAY CONTAIN KNOWN AND UNKNOWN VIOLATIONS OR DEVIATIONS OF INDUSTRY STANDARDS AND SPECIFICATIONS. NVIDIA MAKES NO WARRANTIES, EXPRESSED, IMPLIED, STATUTORY OR OTHERWISE WITH RESPECT TO THE MATERIALS OR OTHERWISE, AND EXPRESSLY DISCLAIMS ALL IMPLIED WARRANTIES INCLUDING, WITHOUT LIMITATION, THE WARRANTIES OF DESIGN, OF NONINFRINGEMENT, MERCHANTABILITY OR FITNESS FOR A PARTICULAR PURPOSE, OR ARISING FROM A COURSE OF DEALING, TRADE USAGE, TRADE PRACTICE, OR INDUSTRY STANDARDS.

ASSEMBLY PAGE DETAIL	-ASSEMBLY_DESCRIPTION- GPU Decoupling
----------------------	---------------------------------------

		Galaxy Microsystems (HK) Ltd.	
Page Name: GPU Decoupling			
Size: Custom	Project Name: P45U	Design By: Carson	Rev: V10
Date: Thursday, December 28, 2017	Sheet 17 of 37		
PROPERTY NOTE: This document contains information confidential and property to Galaxy Microsystems (HK) Ltd.			

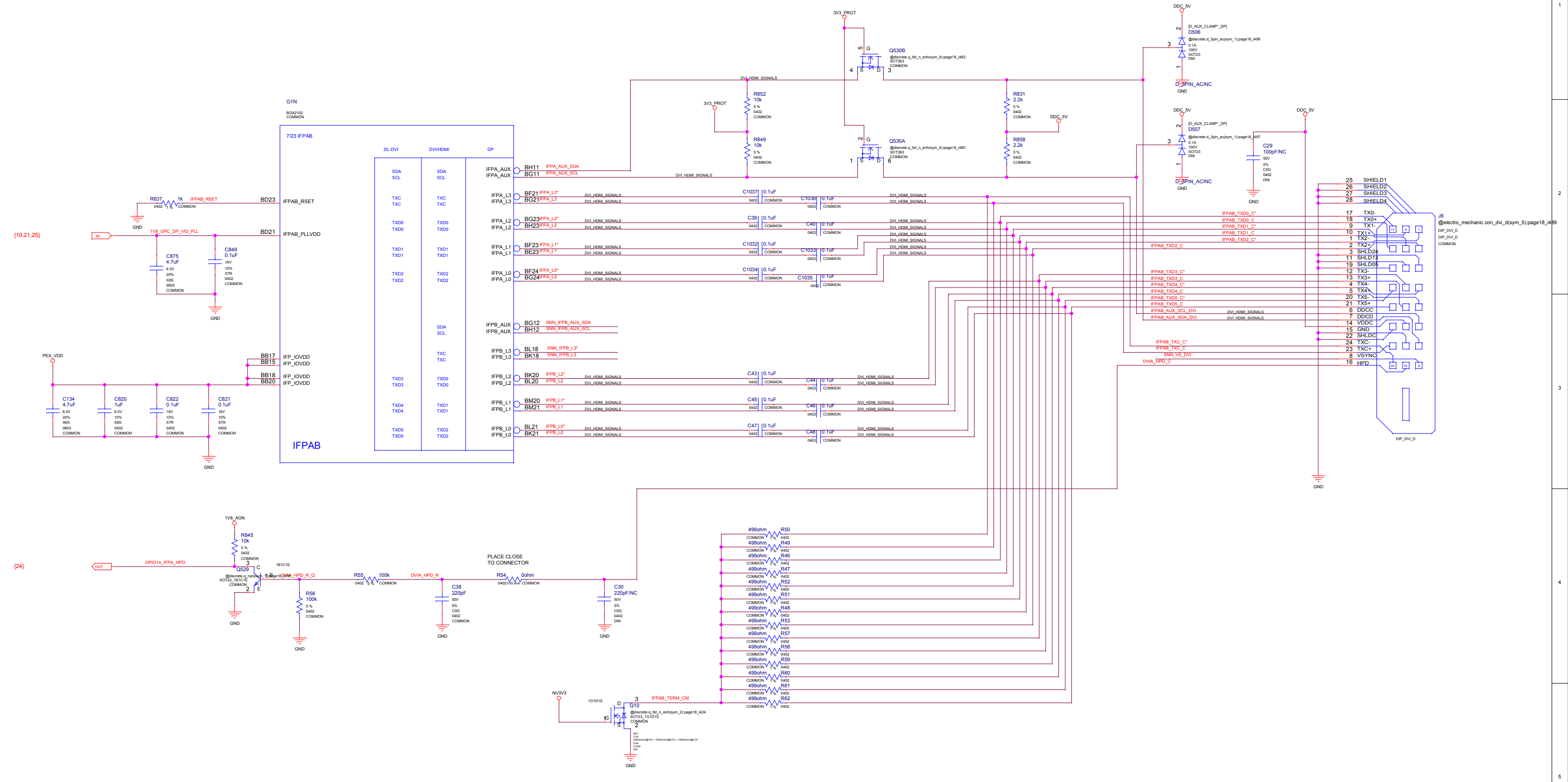

ALL NVIDIA DESIGN SPECIFICATIONS, REFERENCE SPECIFICATIONS, REFERENCE BOARDS, FILES, DRAWINGS, DIAGNOSTICS, LISTS AND OTHER DOCUMENTS OR INFORMATION (TOGETHER AND SEPARATELY, "MATERIALS") ARE BEING PROVIDED "AS IS". THE MATERIALS MAY CONTAIN KNOWN AND UNKNOWN VIOLATIONS OR DEVIATIONS OF INDUSTRY STANDARDS AND SPECIFICATIONS. NVIDIA MAKES NO WARRANTIES, EXPRESSED, IMPLIED, STATUTORY OR OTHERWISE WITH RESPECT TO THE MATERIALS OR OTHERWISE, AND EXPRESSLY DISCLAIMS ALL IMPLIED WARRANTIES INCLUDING, WITHOUT LIMITATION, THE WARRANTIES OF DESIGN, OF NONINFRINGEMENT, MERCHANTABILITY OR FITNESS FOR A PARTICULAR PURPOSE, OR ARISING FROM A COURSE OF DEALING, TRADE USAGE, TRADE PRACTICE, OR INDUSTRY STANDARDS.

ASSEMBLY PAGE DETAIL	<ASSEMBLY_DESCRIPTION> IFPAB DVI-D-DL
----------------------	--

**GALAXY** Galaxy Microsystems (HK) Ltd.

Page Name: IFPAB DVI-D-DL

Size: Custom	Project Name: P45U	Design By: Carson	Rev: V10
Date: Thursday, December 28, 2017	Sheet: 18	of: 37	

PROPERTY NOTE: This document contains information confidential and property to Galaxy Microsystems (HK) Ltd.

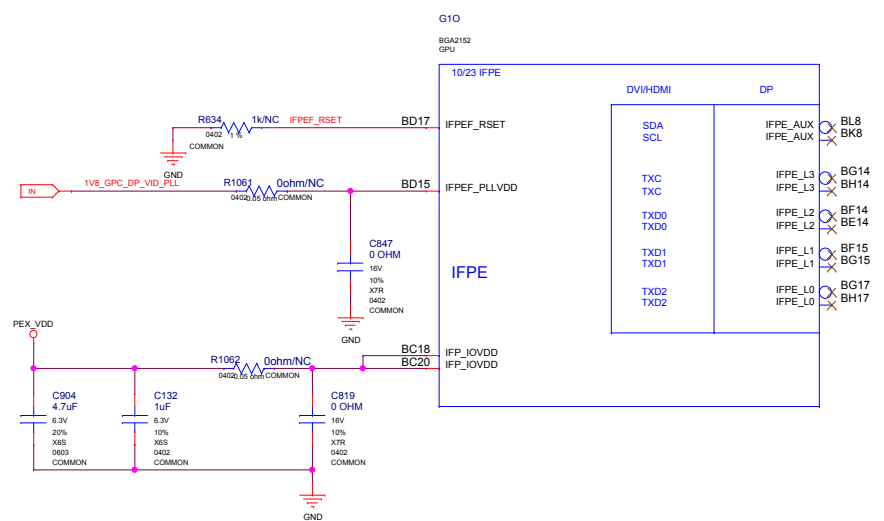

25)

5

ALL NVIDIA DESIGN SPECIFICATIONS, REFERENCE SPECIFICATIONS, REFERENCE BOARDS, FILES, DRAWINGS, DIAGNOSTICS, LISTS AND OTHER DOCUMENTS OR INFORMATION (TOGETHER AND SEPARATELY, "MATERIALS") ARE BEING PROVIDED "AS IS". THE MATERIALS MAY CONTAIN KNOWN AND UNKNOWN VIOLATIONS OR DEVIATIONS OF INDUSTRY STANDARDS AND SPECIFICATIONS. NVIDIA MAKES NO WARRANTIES, EXPRESSED, IMPLIED, STATUTORY OR OTHERWISE WITH RESPECT TO THE MATERIALS OR OTHERWISE, AND EXPRESSLY DISCLAIMS ALL IMPLIED WARRANTIES INCLUDING, WITHOUT LIMITATION, THE WARRANTIES OF DESIGN, OF NON-INFRINGEMENT, MERCHANTABILITY OR FITNESS FOR A PARTICULAR PURPOSE, OR ARISING FROM A COURSE OF DEALING, TRADE USAGE, TRADE PRACTICE, OR INDUSTRY STANDARDS.

ASSEMBLY PAGE DETAIL	<ASSEMBLY_DESCRIPTION> IFPE DP
-------------------------	-----------------------------------

		Galaxy Microsystems (HK) Ltd.	
Page Name: IFPE UNUSED			
Size: Custom	Project Name: P45U	Design By: Carson	Rev: V10
Date: Thursday, December 28, 2017	Sheet 19 of 37		
PROPERTY NOTE: This document contains information confidential and property to Galaxy Microsystems (HK) Ltd.			

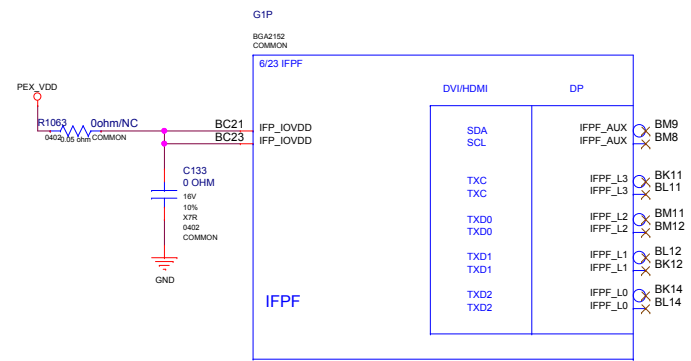

ALL NVIDIA DESIGN SPECIFICATIONS, REFERENCE SPECIFICATIONS, REFERENCE BOARDS, FILES, DRAWINGS, DIAGNOSTICS, LISTS AND OTHER DOCUMENTS OR INFORMATION (TOGETHER AND SEPARATELY, 'MATERIALS') ARE BEING PROVIDED 'AS IS'. THE MATERIALS MAY CONTAIN KNOWN AND UNKNOWN VIOLATIONS OR DEVIATIONS OF INDUSTRY STANDARDS AND SPECIFICATIONS. NVIDIA MAKES NO WARRANTIES, EXPRESSED, IMPLIED, STATUTORY OR OTHERWISE WITH RESPECT TO THE MATERIALS OR OTHERWISE, AND EXPRESSLY DISCLAIMS ALL IMPLIED WARRANTIES INCLUDING, WITHOUT LIMITATION, THE WARRANTIES OF DESIGN, OF NON-INFRINGEMENT, MERCHANTABILITY OR FITNESS FOR A PARTICULAR PURPOSE, OR ARISING FROM A COURSE OF DEALING, TRADE USAGE, TRADE PRACTICE, OR INDUSTRY STANDARDS.

ASSEMBLY PAGE DETAIL	<ASSEMBLY_DESCRIPTION> IFPF DP
-------------------------	-----------------------------------

		Galaxy Microsystems (HK) Ltd.	
Page Name: IFPF UNUSED			
Size: Custom	Project Name: P45U	Design By: Carson	Rev: V10
Date: Thursday, December 28, 2017	Sheet: 20	of	37
PROPERTY NOTE: This document contains information confidential and property to Galaxy Microsystems (HK) Ltd.			

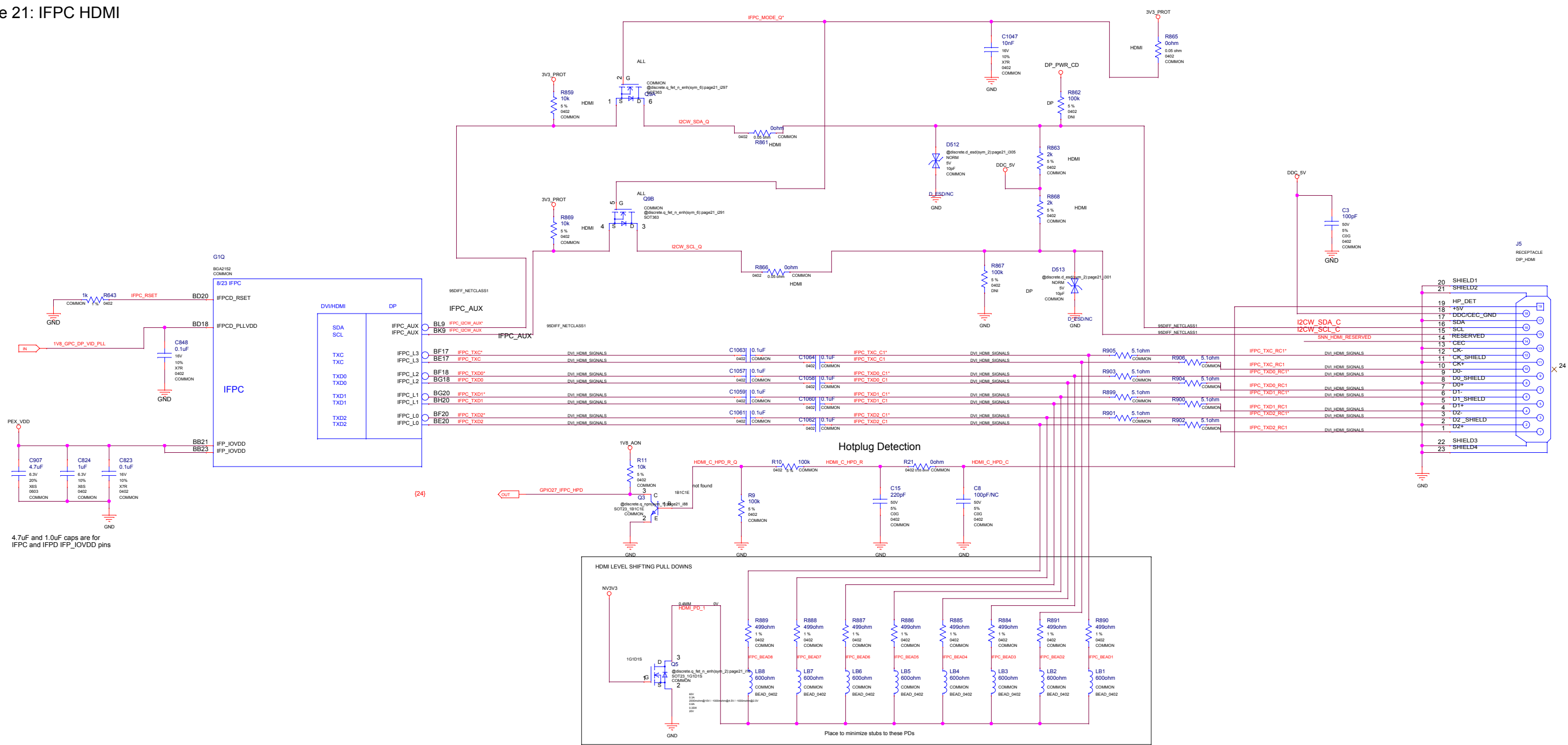

4.7uF and 1.0uF caps are for IFPC and IFPD IFP\_IOVDD pins

(24)

Hotplug Detection

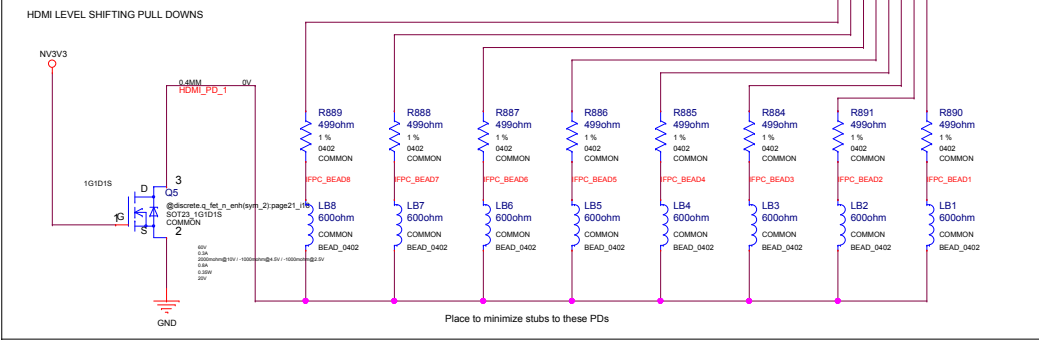

Place to minimize stubs to these PDs

		Galaxy Microsystems (HK) Ltd.	
Page Name: IFPC HDMI			
Size: Custom	Project Name: P45U	Design By: Carson	Rev: V10
Date: Thursday, December 28, 2017	Sheet: 21	of 37	
PROPERTY NOTE: This document contains information confidential and property to Galaxy Microsystems (HK) Ltd.			

ALL NVIDIA DESIGN SPECIFICATIONS, REFERENCE SPECIFICATIONS, REFERENCE BOARDS, FILES, DRAWINGS, DIAGNOSTICS, LISTS AND OTHER DOCUMENTS OR INFORMATION (TOGETHER AND SEPARATELY, 'MATERIALS') ARE BEING PROVIDED 'AS IS'. THE MATERIALS MAY CONTAIN KNOWN AND UNKNOWN VIOLATIONS OR DEVIATIONS OF INDUSTRY STANDARDS AND SPECIFICATIONS. NVIDIA MAKES NO WARRANTIES, EXPRESSED, IMPLIED, STATUTORY OR OTHERWISE WITH RESPECT TO THE MATERIALS OR OTHERWISE, AND EXPRESSLY DISCLAIMS ALL IMPLIED WARRANTIES INCLUDING, WITHOUT LIMITATION, THE WARRANTIES OF DESIGN, OF NONINFRINGEMENT, MERCHANTABILITY OR FITNESS FOR A PARTICULAR PURPOSE, OR ARISING FROM A COURSE OF DEALING, TRADE USAGE, TRADE PRACTICE, OR INDUSTRY STANDARDS.

ASSEMBLY PAGE DETAIL	<ASSEMBLY_DESCRIPTION> IFPC HDMI/DP
----------------------	-------------------------------------

Two cases to be considered:  
 1. DP AUX to DP connector: AUX AC coupled  
 2. DP AUX to DP-DVI dongle: AUX pass through

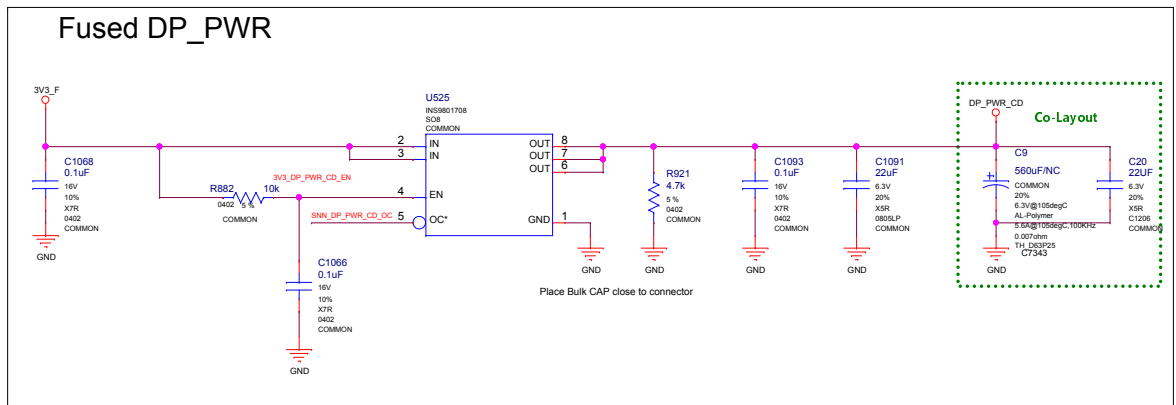
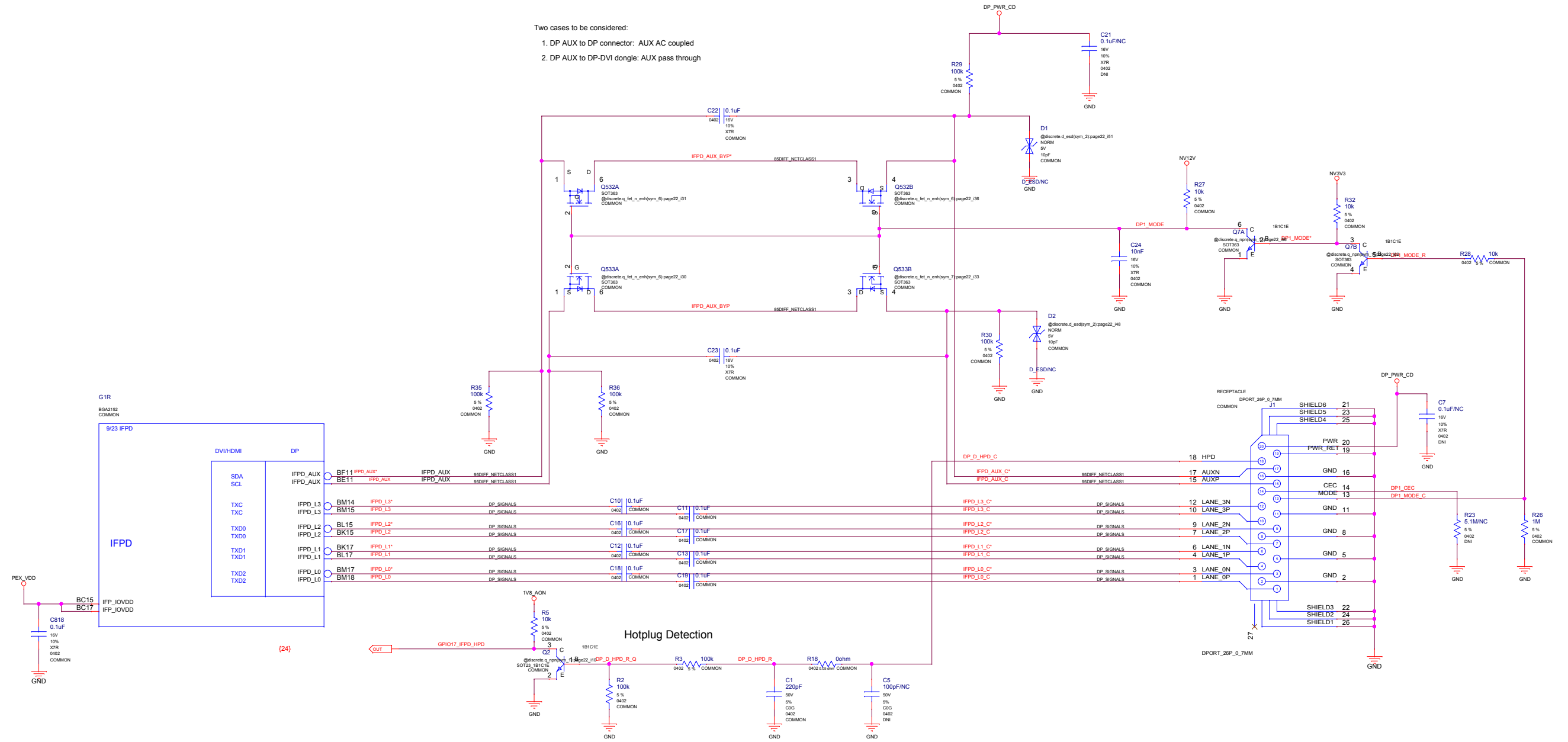

ASSEMBLY PAGE DETAIL	-ASSEMBLY_DESCRIPTION- IFPD DP
----------------------	-----------------------------------

ALL NVIDIA DESIGN SPECIFICATIONS, REFERENCE SPECIFICATIONS, REFERENCE BOARDS, FILES, DRAWINGS, DIAGNOSTICS, LISTS AND OTHER DOCUMENTS OR INFORMATION (TOGETHER AND SEPARATELY, "MATERIALS") ARE BEING PROVIDED "AS IS". THE MATERIALS MAY CONTAIN KNOWN AND UNKNOWN VIOLATIONS OR DEVIATIONS OF INDUSTRY STANDARDS AND SPECIFICATIONS. NVIDIA MAKES NO WARRANTIES, EXPRESSED, IMPLIED, STATUTORY OR OTHERWISE WITH RESPECT TO THE MATERIALS OR OTHERWISE, AND EXPRESSLY DISCLAIMS ALL IMPLIED WARRANTIES INCLUDING, WITHOUT LIMITATION, THE WARRANTIES OF DESIGN, OF NONINFRINGEMENT, MERCHANTABILITY OR FITNESS FOR A PARTICULAR PURPOSE, OR ARISING FROM A COURSE OF DEALING, TRADE USAGE, TRADE PRACTICE, OR INDUSTRY STANDARDS.

**GALAXY** Galaxy Microsystems (HK) Ltd.

Page Name: IFPD DP

Size: Custom	Project Name: P45U	Design By: Carson	Rev: V10
Date: Thursday, December 28, 2017	Sheet: 22	of 37	

PROPERTY NOTE: This document contains information confidential and property to Galaxy Microsystems (HK) Ltd.

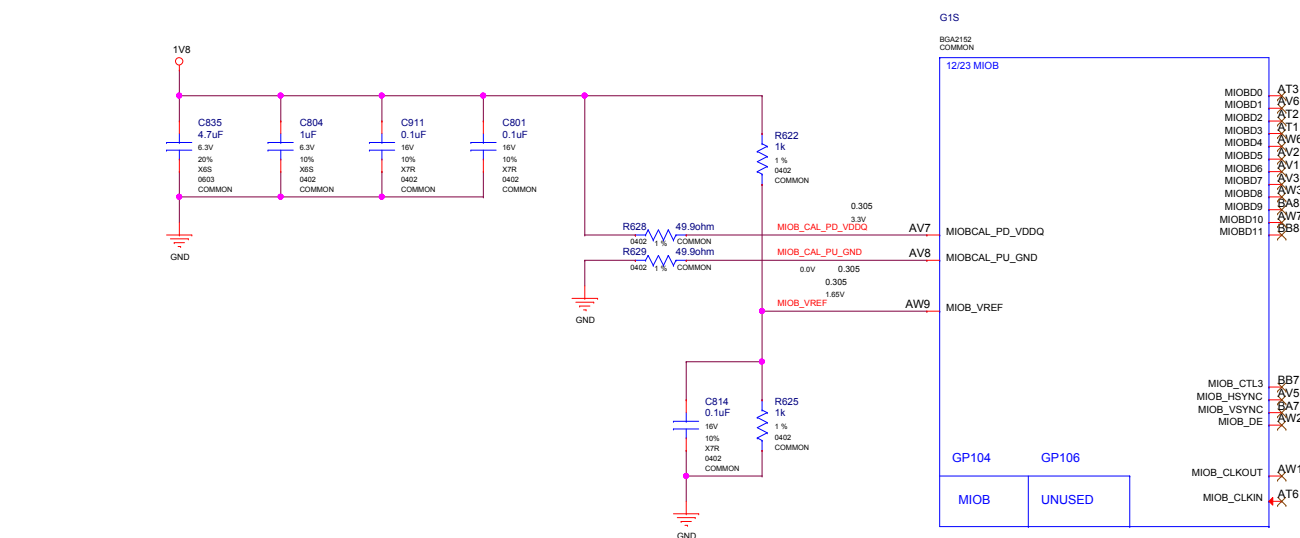
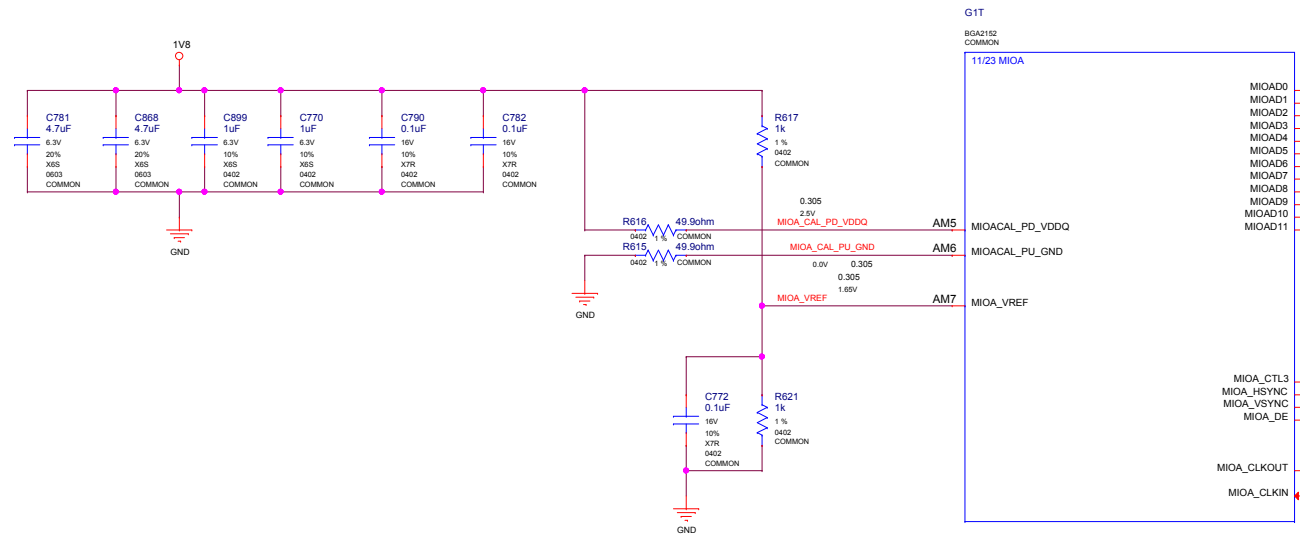

ASSEMBLY PAGE DETAIL	<ASSEMBLY_DESCRIPTION> MIOA/B Interface and Frame Lock
----------------------	---

**GALAXY** Galaxy Microsystems (HK) Ltd.

Page Name: MIOA/B Interface and Frame Lock

Size: Custom	Project Name: P45U	Design By: Carson	Rev: V10
Date: Thursday, December 28, 2017	Sheet: 23	of: 37	

PROPERTY NOTE: This document contains information confidential and property to Galaxy Microsystems (HK) Ltd.

ALL NVIDIA DESIGN SPECIFICATIONS, REFERENCE SPECIFICATIONS, REFERENCE BOARDS, FILES, DRAWINGS, DIAGNOSTICS, LISTS AND OTHER DOCUMENTS OR INFORMATION (TOGETHER AND SEPARATELY, 'MATERIALS') ARE BEING PROVIDED 'AS IS'. THE MATERIALS MAY CONTAIN KNOWN AND UNKNOWN VIOLATIONS OR DEVIATIONS OF INDUSTRY STANDARDS AND SPECIFICATIONS. NVIDIA MAKES NO WARRANTIES, EXPRESSED, IMPLIED, STATUTORY OR OTHERWISE WITH RESPECT TO THE MATERIALS OR OTHERWISE, AND EXPRESSLY DISCLAIMS ALL IMPLIED WARRANTIES INCLUDING, WITHOUT LIMITATION, THE WARRANTIES OF DESIGN, OF NONINFRINGEMENT, MERCHANTABILITY OR FITNESS FOR A PARTICULAR PURPOSE, OR ARISING FROM A COURSE OF DEALING, TRADE USAGE, TRADE PRACTICE, OR INDUSTRY STANDARDS.

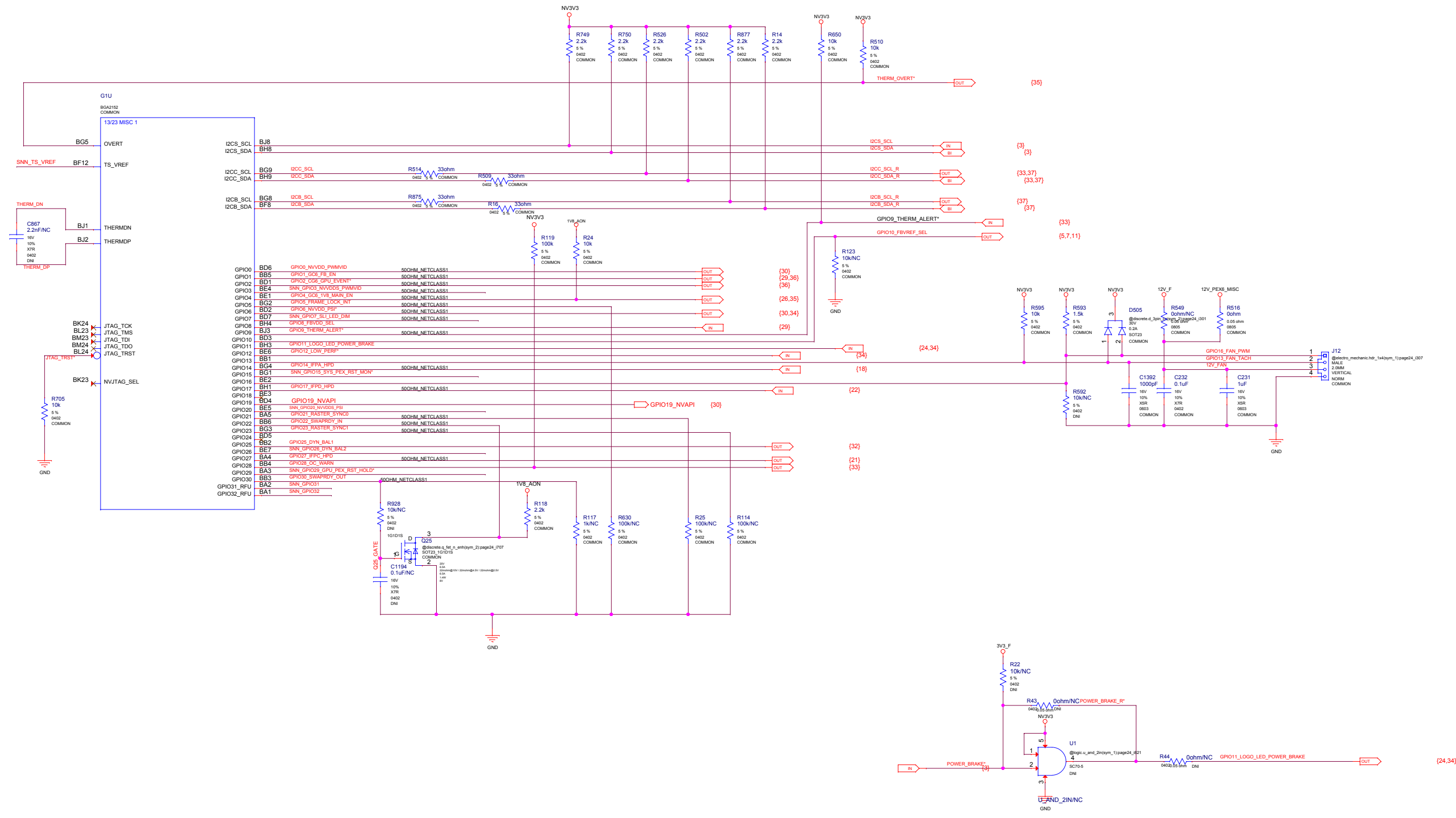

ALL NVIDIA DESIGN SPECIFICATIONS, REFERENCE SPECIFICATIONS, REFERENCE BOARDS, FILES, DRAWINGS, DIAGNOSTICS, LISTS AND OTHER DOCUMENTS OR INFORMATION (TOGETHER AND SEPARATELY, "MATERIALS") ARE BEING PROVIDED "AS IS". THE MATERIALS MAY CONTAIN KNOWN AND UNKNOWN VIOLATIONS OR DEVIATIONS OF INDUSTRY STANDARDS AND SPECIFICATIONS. NVIDIA MAKES NO WARRANTIES, EXPRESSED, IMPLIED, STATUTORY OR OTHERWISE WITH RESPECT TO THE MATERIALS OR OTHERWISE, AND EXPRESSLY DISCLAIMS ALL IMPLIED WARRANTIES INCLUDING, WITHOUT LIMITATION, THE WARRANTIES OF DESIGN, OF NON-INFRINGEMENT, MERCHANTABILITY OR FITNESS FOR A PARTICULAR PURPOSE, OR ARISING FROM A COURSE OF DEALING, TRADE USAGE, TRADE PRACTICE, OR INDUSTRY STANDARDS.

ASSEMBLY PAGE DETAIL	<ASSEMBLY_DESCRIPTION> MISC1: Fan, Thermal, JTAG, GPIO, STEREO
----------------------	---

**GALAXY** Galaxy Microsystems (HK) Ltd.

Page Name: MISC1: Fan, Thermal, JTAG, GPIO, STEREO

Size: Custom	Project Name: P45U	Design By: Carson	Rev: V10
Date: Thursday, December 28, 2017	Sheet: 24	of: 37	

PROPERTY NOTE: This document contains information confidential and property to Galaxy Microsystems (HK) Ltd.



STRAP2	STRAP1	STRAP0	RAMCFG[4:0]
L	L	L	00000
L	L	H	00001
L	H	L	00010
L	H	H	00011
H	H	L	00110
H	H	H	00111
L	L	M	01000

ROM_SO	ROM_SI	ROM_SCLK	SOR_EXPOSED[3:0]	1:ENABLE 0:DISABLE
L	L	L	1111 DEFAULT	SOR0/1/2/3 ENABLE
L	L	H	1110	
L	H	L	1101	
L	H	H	1100	
H	L	L	1011	
H	L	H	1010	
H	H	L	1001	
H	H	H	1000	
L	L	M	0111	
L	L	L	0110	
L	M	L	0101	
L	M	H	0100	
H	L	M	0011	
H	M	L	0010	
H	M	H	0001	
H	H	M	0000	

STRAP5	STRAP4	STRAP3	SMB_ALT_ADDR	DEVID_SEL	PCIE_CFG	VGA_DEVICE
M	H	H	1	1	1	1
M	H	L	1	1	1	0
M	L	H	1	1	0	1
M	L	L	1	1	0	0
L	H	M	1	0	1	1
L	M	H	1	0	0	0
L	M	L	1	0	0	0
H	H	H	0	1	1	1
H	H	L	0	1	1	0
H	L	H	0	1	0	1
H	L	L	0	1	0	0
L	H	H	0	0	1	1
L	H	L	0	0	1	0
L	L	H	0	0	0	1 DEFAULT
L	L	L	0	0	0	0

H=High :Tied to 1.8V  
M=Middle:Tied to 0.9V  
L=Low :Tied to 0V

1:SMB\_ALT\_ADDR ENABLE  
0:SMB\_ALT\_ADDR DISABLE  
1:DEVID\_SEL REBRAND  
0:DEVID\_SEL ORIGINAL  
1:PCIE\_CFG LOW POWER  
0:PCIE\_CFG HIGH POWER  
1:VGA\_DEVICE ENABLE  
0:VGA\_DEVICE DISABLE

ASSEMBLY PAGE DETAIL <ASSEMBLY\_DESCRIPTION> MISC2: ROM, XTAL,STRAPS

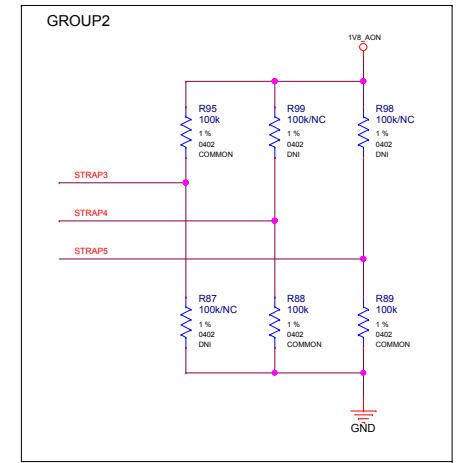
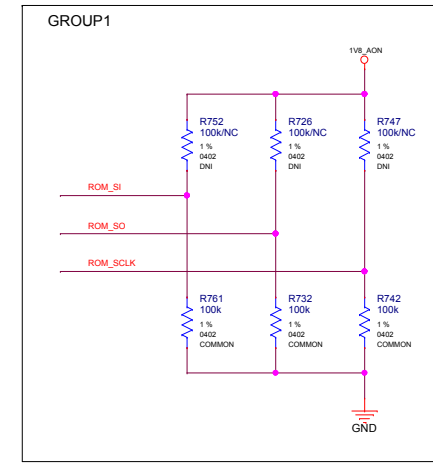
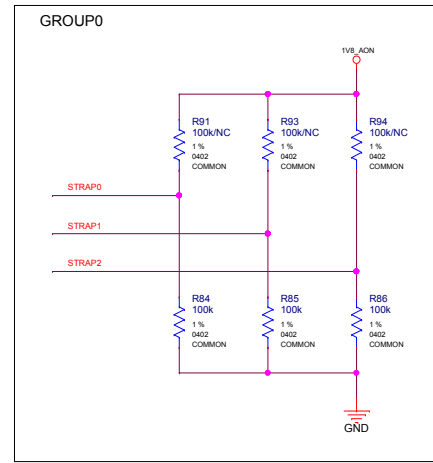

CFG[3:0]	Config	Width	Vendor
0000	256Mx32	256-bit	Samsung
0001	256Mx32	256-bit	Micron
0010	256Mx32	256-bit	Hynix
0011	Reserved		
0100	Reserved		
0101	Reserved		
0110	Reserved		
0111	Reserved		

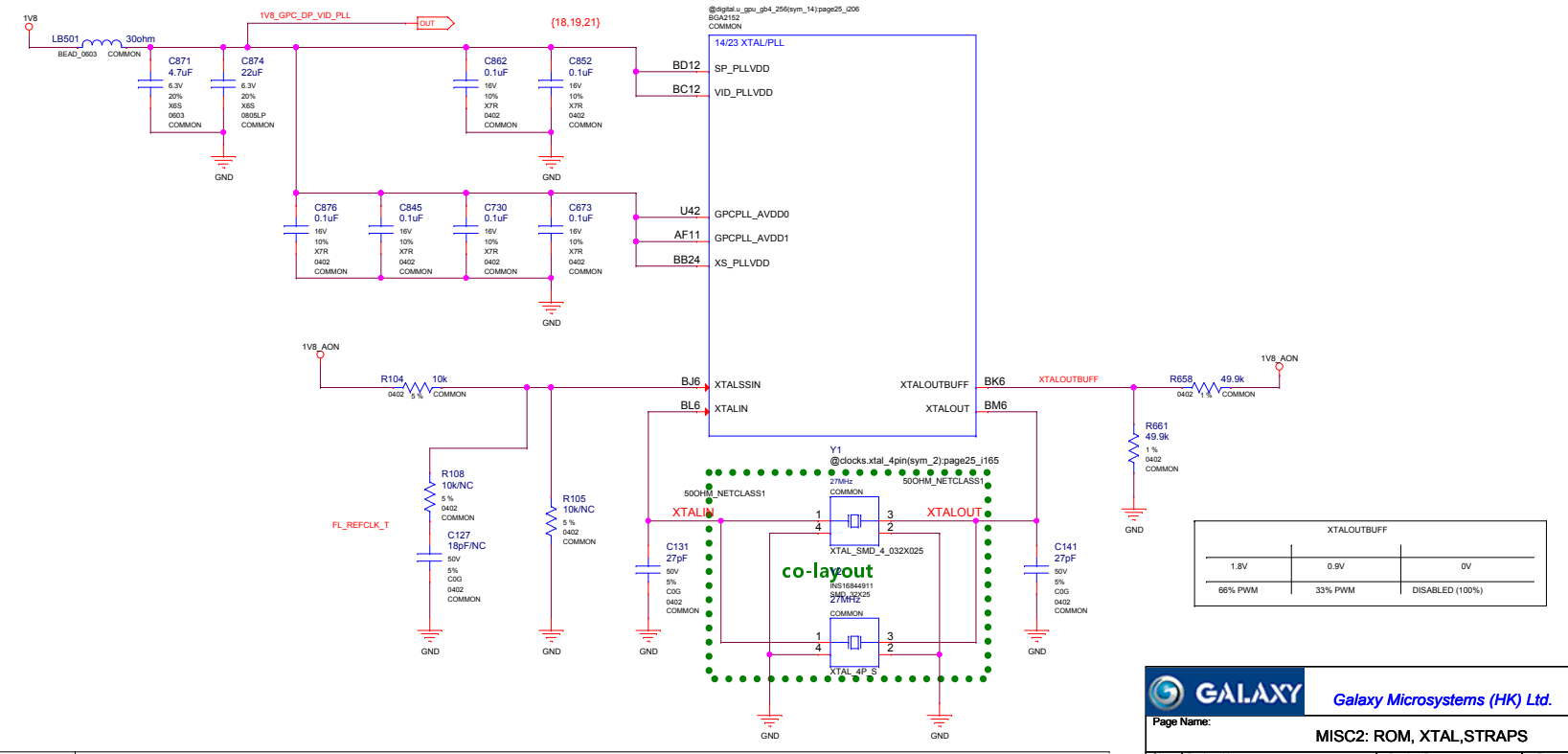
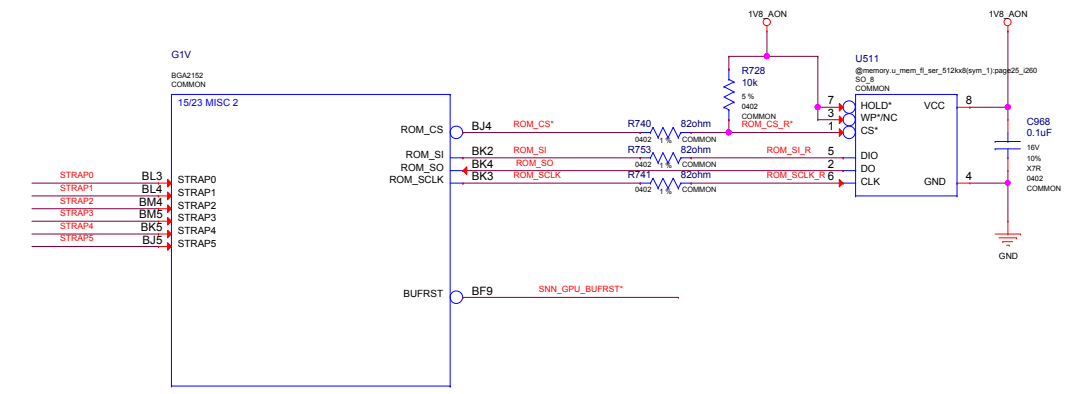

XTALOUTBUFF		
1.8V	0.9V	0V
66% PWM	33% PWM	DISABLED (100%)

**GALAXY** Galaxy Microsystems (HK) Ltd.

Page Name: MISC2: ROM, XTAL,STRAPS

Size: Custom Project Name: P45U Design By: Carson Rev: V10

Date: Thursday, December 28, 2017 Sheet: 25 of 37

PROPERTY NOTE: This document contains information confidential and property to Galaxy Microsystems (HK) Ltd.

ALL NVIDIA DESIGN SPECIFICATIONS, REFERENCE SPECIFICATIONS, REFERENCE BOARDS, FILES, DRAWINGS, DIAGNOSTICS, LISTS AND OTHER DOCUMENTS OR INFORMATION (TOGETHER AND SEPARATELY, 'MATERIALS') ARE BEING PROVIDED 'AS IS'. THE MATERIALS MAY CONTAIN KNOWN AND UNKNOWN VIOLATIONS OR DEVIATIONS OF INDUSTRY STANDARDS AND SPECIFICATIONS. NVIDIA MAKES NO WARRANTIES, EXPRESSED, IMPLIED, STATUTORY OR OTHERWISE WITH RESPECT TO THE MATERIALS OR OTHERWISE, AND EXPRESSLY DISCLAIMS ALL IMPLIED WARRANTIES INCLUDING, WITHOUT LIMITATION, THE WARRANTIES OF DESIGN, OF NON-INFRINGEMENT, MERCHANTABILITY OR FITNESS FOR A PARTICULAR PURPOSE, OR ARISING FROM A COURSE OF DEALING, TRADE PRACTICE, OR INDUSTRY STANDARDS.

# 1v8 Switcher

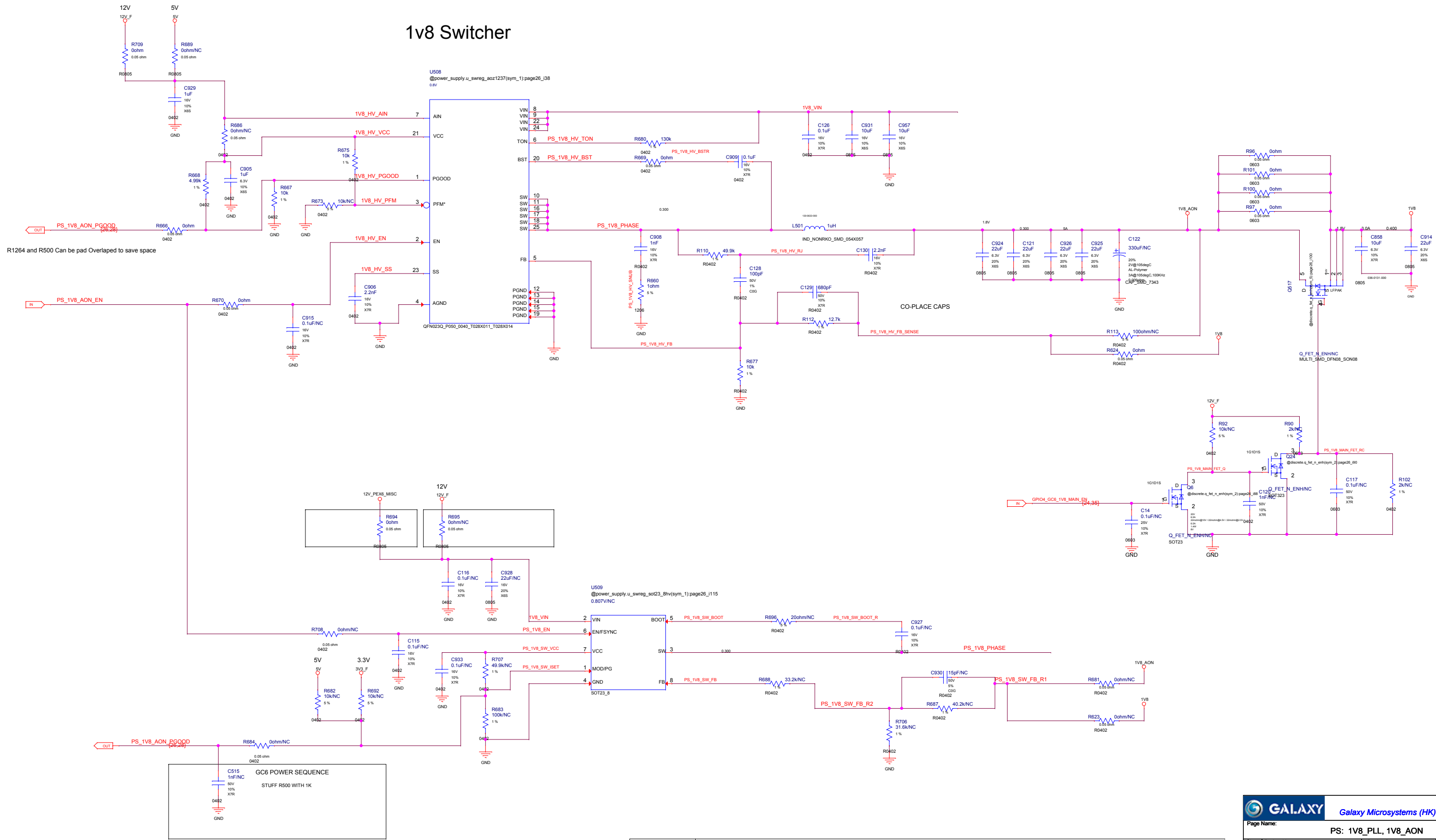

28,29,35

ASSEMBLY PAGE DETAIL	<ASSEMBLY_DESCRIPTION> PS: 1V8_PLL, 1V8_AON
----------------------	--

<b>GALAXY</b> Galaxy Microsystems (HK) Ltd.			
Page Name: PS: 1V8_PLL, 1V8_AON			
Size: Custom	Project Name: P45U	Design By: Carson	Rev: V10
Date: Thursday, December 28, 2017	Sheet: 26	of 37	
PROPERTY NOTE: This document contains information confidential and property to Galaxy Microsystems (HK) Ltd.			

ALL NVIDIA DESIGN SPECIFICATIONS, REFERENCE SPECIFICATIONS, REFERENCE BOARDS, FILES, DRAWINGS, DIAGNOSTICS, LISTS AND OTHER DOCUMENTS OR INFORMATION (TOGETHER AND SEPARATELY, 'MATERIALS') ARE BEING PROVIDED 'AS IS'. THE MATERIALS MAY CONTAIN KNOWN AND UNKNOWN VIOLATIONS OR DEVIATIONS OF INDUSTRY STANDARDS AND SPECIFICATIONS. NVIDIA MAKES NO WARRANTIES, EXPRESSED, IMPLIED, STATUTORY OR OTHERWISE WITH RESPECT TO THE MATERIALS OR OTHERWISE, AND EXPRESSLY DISCLAIMS ALL IMPLIED WARRANTIES INCLUDING, WITHOUT LIMITATION, THE WARRANTIES OF DESIGN, OF NONINFRINGEMENT, MERCHANTABILITY OR FITNESS FOR A PARTICULAR PURPOSE, OR ARISING FROM A COURSE OF DEALING, TRADE USAGE, TRADE PRACTICE, OR INDUSTRY STANDARDS.

PEX PLL Switcher

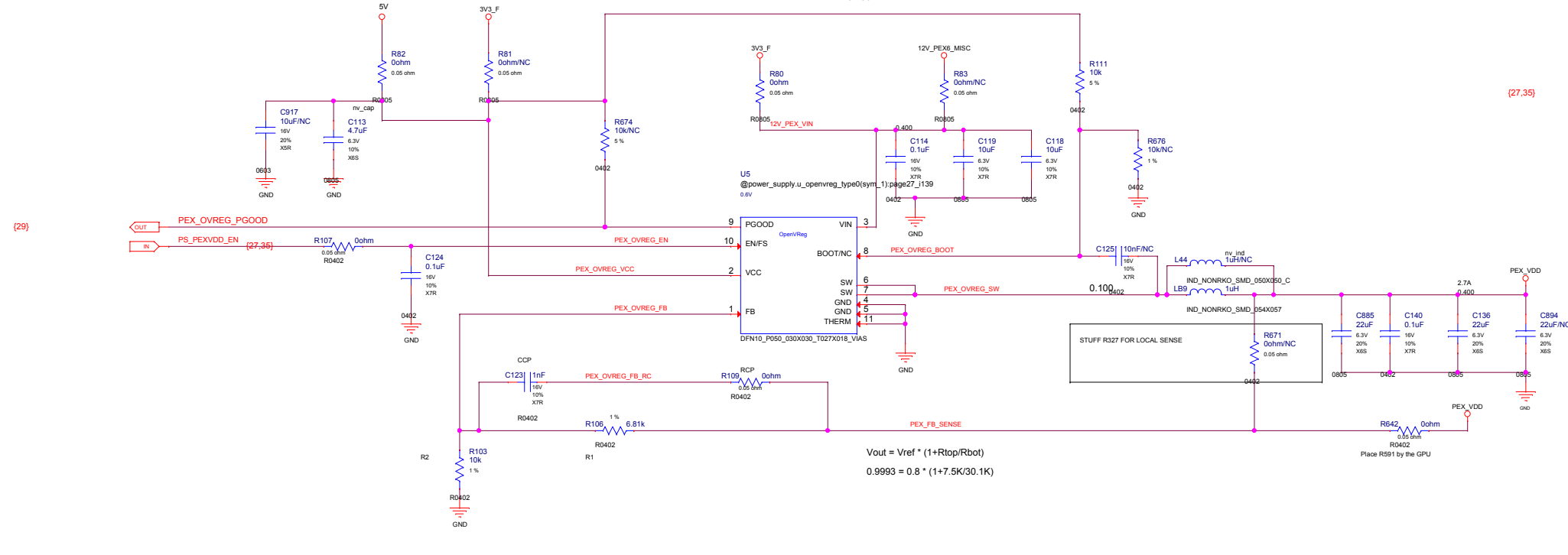

PEX\_VDD DISCHARGE

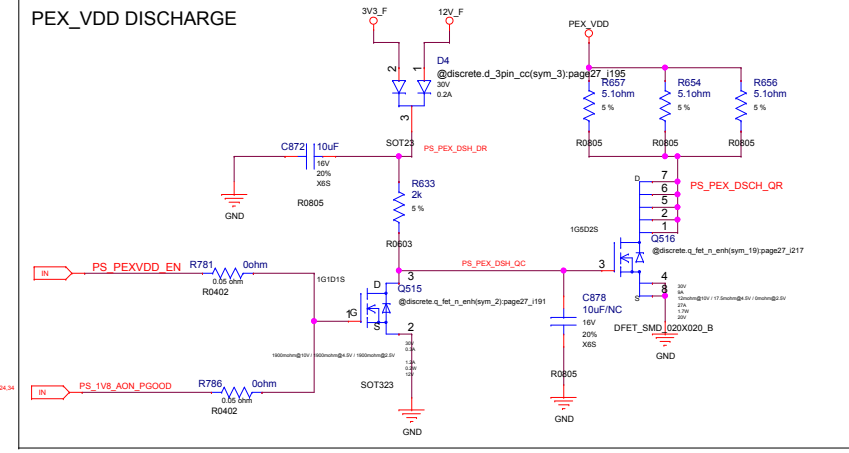

5V Switcher

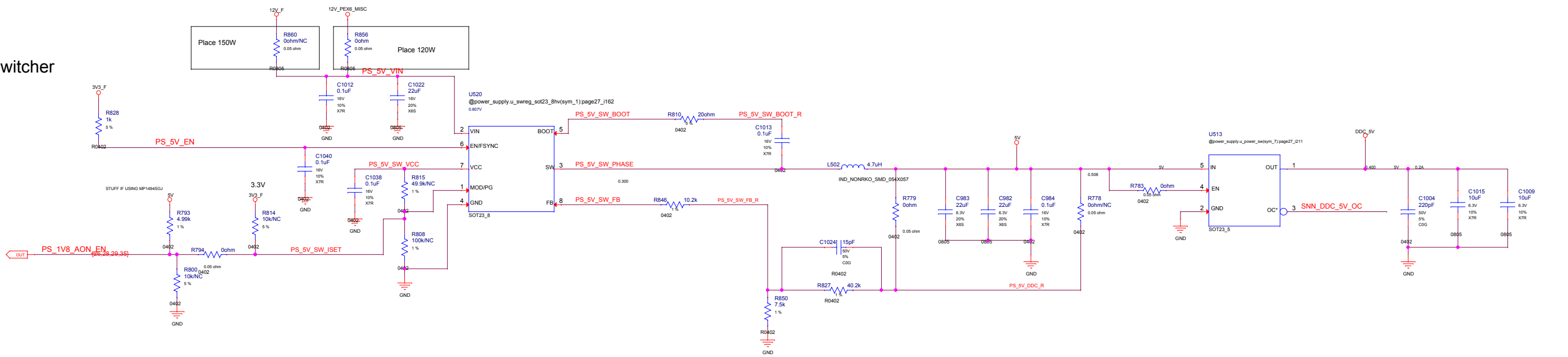

ALL NVIDIA DESIGN SPECIFICATIONS, REFERENCE SPECIFICATIONS, REFERENCE BOARDS, FILES, DRAWINGS, DIAGNOSTICS, LISTS AND OTHER DOCUMENTS OR INFORMATION (TOGETHER AND SEPARATELY, "MATERIALS") ARE BEING PROVIDED "AS IS". THE MATERIALS MAY CONTAIN KNOWN AND UNKNOWN VIOLATIONS OR DEVIATIONS OF INDUSTRY STANDARDS AND SPECIFICATIONS. NVIDIA MAKES NO WARRANTIES, EXPRESSED, IMPLIED, STATUTORY OR OTHERWISE WITH RESPECT TO THE MATERIALS OR OTHERWISE, AND EXPRESSLY DISCLAIMS ALL IMPLIED WARRANTIES INCLUDING, WITHOUT LIMITATION, THE WARRANTIES OF DESIGN, OF NONINFRINGEMENT, MERCHANTABILITY OR FITNESS FOR A PARTICULAR PURPOSE, OR ARISING FROM A COURSE OF DEALING, TRADE USAGE, TRADE PRACTICE, OR INDUSTRY STANDARDS.

ASSEMBLY PAGE DETAIL	<ASSEMBLY_DESCRIPTION> PS: 5V, PEX_VDD
----------------------	---

**GALAXY** Galaxy Microsystems (HK) Ltd.

Page Name: PS: 5V, PEX\_VDD

Size: Custom	Project Name: P45U	Design By: Carson	Rev: V10
Date: Thursday, December 28, 2017	Sheet: 27	of 37	

**PROPERTY NOTE:** This document contains information confidential and property to Galaxy Microsystems (HK) Ltd.

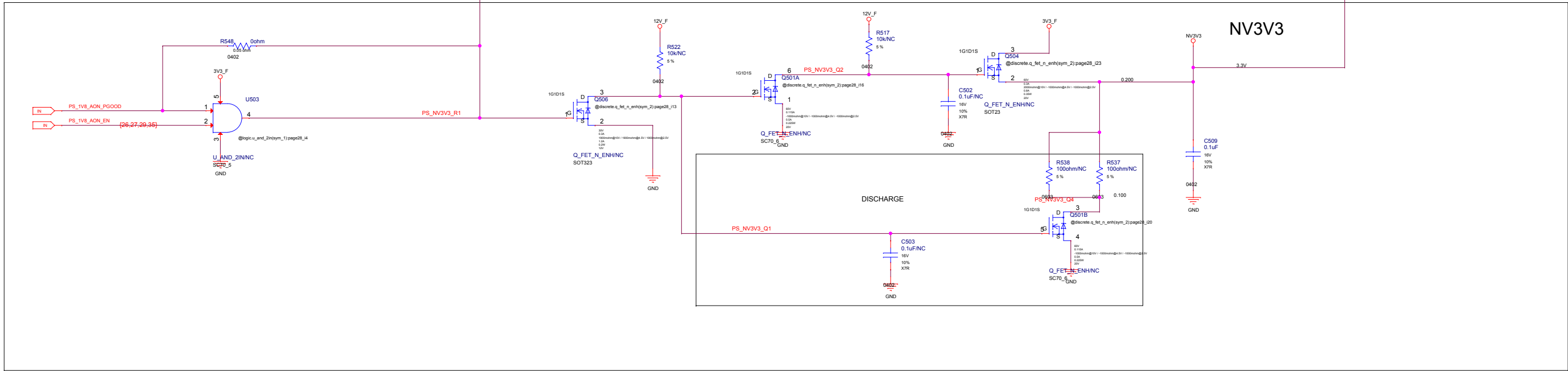
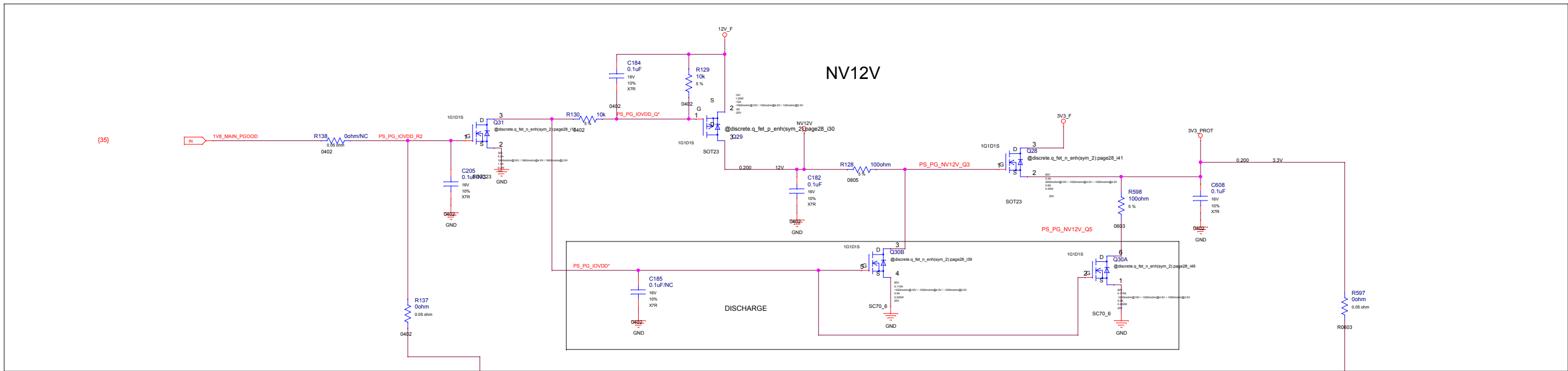

(35)

(26)

ALL NVIDIA DESIGN SPECIFICATIONS, REFERENCE SPECIFICATIONS, REFERENCE BOARDS, FILES, DRAWINGS, DIAGNOSTICS, LISTS AND OTHER DOCUMENTS OR INFORMATION (TOGETHER AND SEPARATELY, "MATERIALS") ARE BEING PROVIDED "AS IS". THE MATERIALS MAY CONTAIN KNOWN AND UNKNOWN VIOLATIONS OR DEVIATIONS OF INDUSTRY STANDARDS AND SPECIFICATIONS. NVIDIA MAKES NO WARRANTIES, EXPRESSED, IMPLIED, STATUTORY OR OTHERWISE WITH RESPECT TO THE MATERIALS OR OTHERWISE, AND EXPRESSLY DISCLAIMS ALL IMPLIED WARRANTIES INCLUDING, WITHOUT LIMITATION, THE WARRANTIES OF DESIGN, OF NON-INFRINGEMENT, MERCHANTABILITY OR FITNESS FOR A PARTICULAR PURPOSE, OR ARISING FROM A COURSE OF DEALING, TRADE USAGE, TRADE PRACTICE, OR INDUSTRY STANDARDS.

ASSEMBLY PAGE DETAIL	<ASSEMBLY_DESCRIPTION> PS: NV3V3, NV12V
----------------------	--

**GALAXY** Galaxy Microsystems (HK) Ltd.

Page Name: PS: NV3V3, NV12V

Size: Custom	Project Name: P45U	Design By: Carson	Rev: V10
Date: Thursday, December 28, 2017	Sheet: 28	of: 37	

PROPERTY NOTE: This document contains information confidential and property to Galaxy Microsystems (HK) Ltd.

FBVDD	NETNAME	MAX_CURRENT	MIN_LINE_WIDTH	VOLTAGE
-------	---------	-------------	----------------	---------

FBVDD/Q Enable

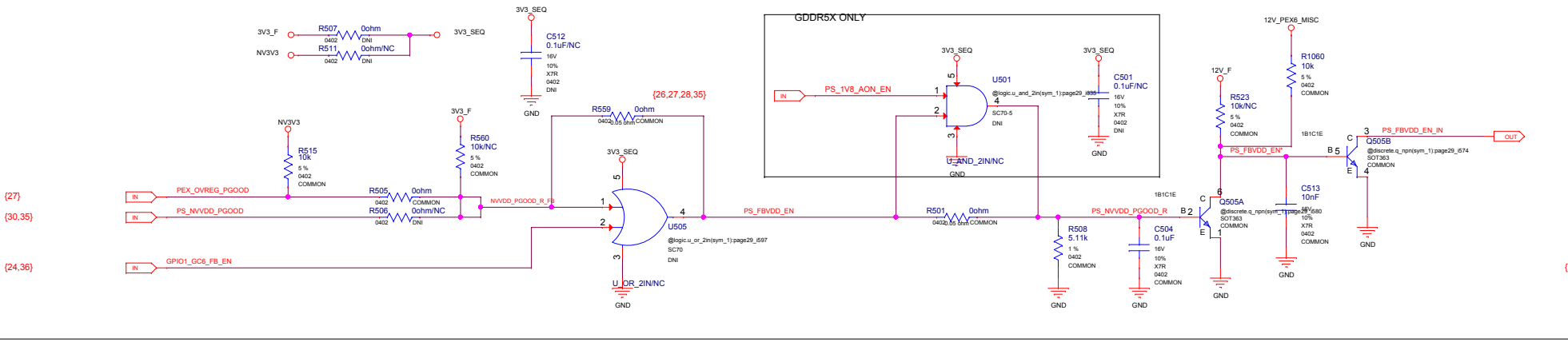

FBVDD DISCHARGE

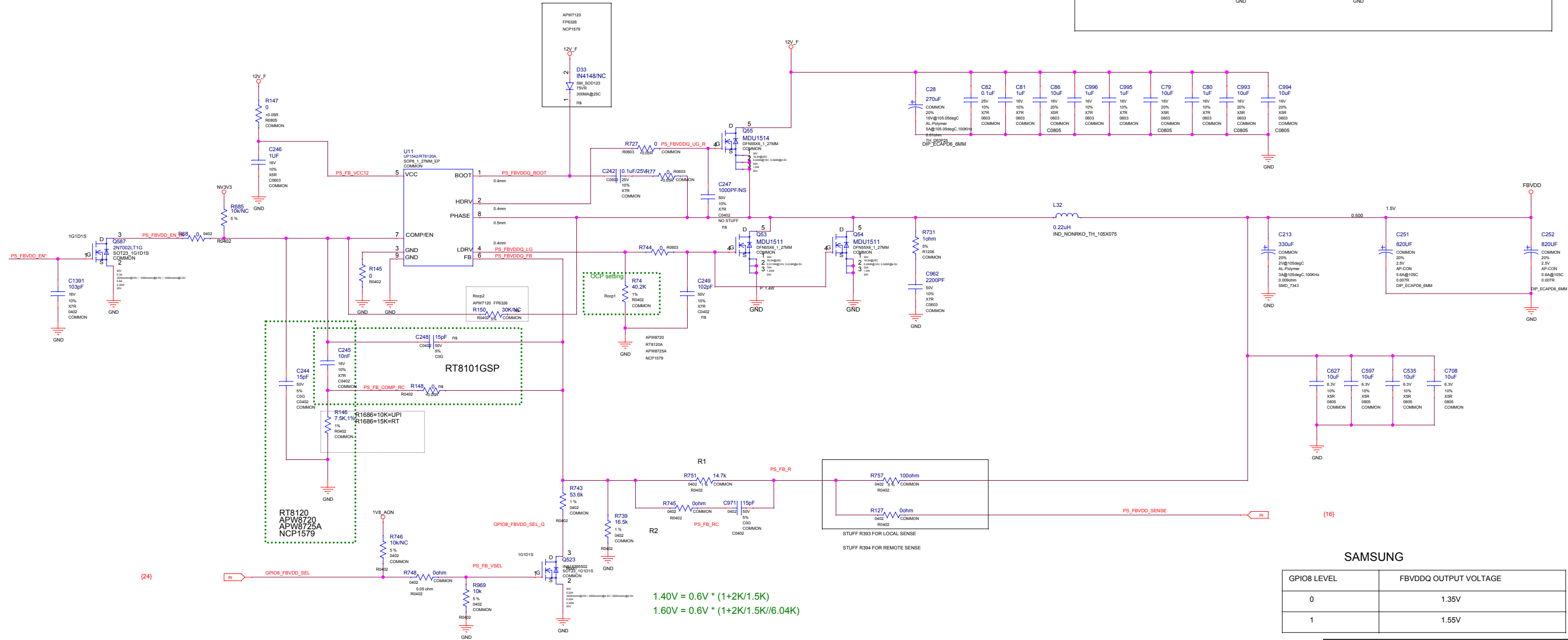
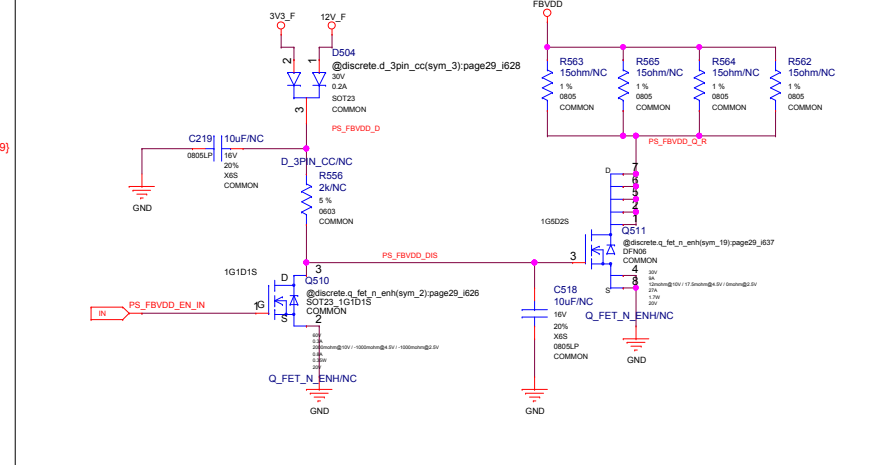

$1.40V = 0.6V * (1+2K/1.5K)$   
 $1.60V = 0.6V * (1+2K/1.5K/6.04K)$

SAMSUNG

GPIO8 LEVEL	FBVDDQ OUTPUT VOLTAGE
0	1.35V
1	1.55V

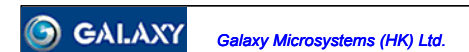

Page Name:	PS: FBVDD		
Size:	Project Name: P45U	Design By: Carson	Rev: V10
Date:	Thursday, December 28, 2017	Sheet: 29	of: 37

ALL NVIDIA DESIGN SPECIFICATIONS, REFERENCE SPECIFICATIONS, REFERENCE BOARDS, FILES, DRAWINGS, DIAGNOSTICS, LISTS AND OTHER DOCUMENTS OR INFORMATION (TOGETHER AND SEPARATELY, "MATERIALS") ARE BEING PROVIDED "AS IS". THE MATERIALS MAY CONTAIN KNOWN AND UNKNOWN VIOLATIONS OR DEVIATIONS OF INDUSTRY STANDARDS AND SPECIFICATIONS. NVIDIA MAKES NO WARRANTIES, EXPRESSED, IMPLIED, STATUTORY OR OTHERWISE WITH RESPECT TO THE MATERIALS OR OTHERWISE, AND EXPRESSLY DISCLAIMS ALL IMPLIED WARRANTIES INCLUDING, WITHOUT LIMITATION, THE WARRANTIES OF DESIGN, OF NONINFRINGEMENT, MERCHANTABILITY OR FITNESS FOR A PARTICULAR PURPOSE, OR ARISING FROM A COURSE OF DEALING, TRADE USAGE, TRADE PRACTICE, OR INDUSTRY STANDARDS.

ASSEMBLY PAGE DETAIL	-ASSEMBLY DESCRIPTION- PS: FBVDD
----------------------	----------------------------------

Initialization voltage: 1.6V

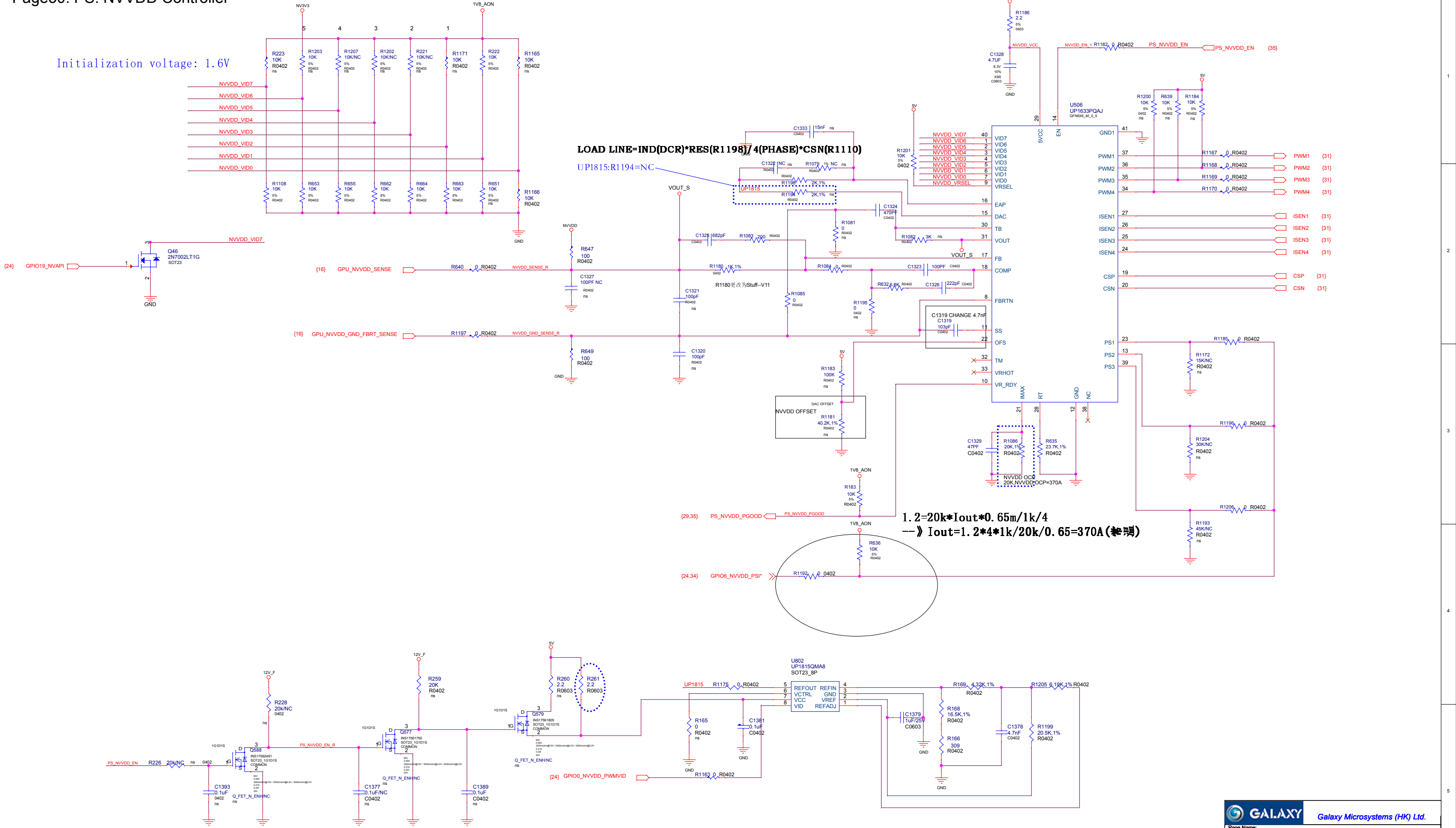

LOAD LINE=IND(DCR)\*RES(R1198)/4(PHASE)\*CSN(R1110)

UPI815:R1194=NC

1.2=20k\*Iout\*0.65m/1k/4

--> Iout=1.2\*4\*1k/20k/0.65=370A (满载)

ALL NVIDIA DESIGN SPECIFICATIONS, REFERENCE SPECIFICATIONS, REFERENCE BOARDS, FILES, DRAWINGS, DIAGNOSTICS, LISTS AND OTHER DOCUMENTS OR INFORMATION (TOGETHER AND SEPARATELY, "MATERIALS") ARE BEING PROVIDED "AS IS". THE MATERIALS MAY CONTAIN KNOWN AND UNKNOWN VIOLATIONS OR DEVIATIONS OF INDUSTRY STANDARDS AND SPECIFICATIONS. NVIDIA MAKES NO WARRANTIES, EXPRESSED, IMPLIED, STATUTORY OR OTHERWISE WITH RESPECT TO THE MATERIALS OR OTHERWISE, AND EXPRESSLY DISCLAIMS ALL IMPLIED WARRANTIES INCLUDING, WITHOUT LIMITATION, THE WARRANTIES OF DESIGN, OF NONINFRINGEMENT, MERCHANTABILITY OR FITNESS FOR A PARTICULAR PURPOSE, OR ARISING FROM A COURSE OF DEALING, TRADE USAGE, TRADE PRACTICE, OR INDUSTRY STANDARDS.

**GALAXY** Galaxy Microsystems (HK) Ltd.

Page Name: PS: NVVDD Controller

Size: Custom	Project Name: P45U	Design By: Carson	Rev: V10
Date: Thursday, December 28, 2017	Sheet: 30	of: 37	

PROPERTY NOTE: This document contains information confidential and property to Galaxy Microsystems (HK) Ltd.

ASSEMBLY PAGE DETAIL	<ASSEMBLY_DESCRIPTION> PS: NVVDD Controller
----------------------	--

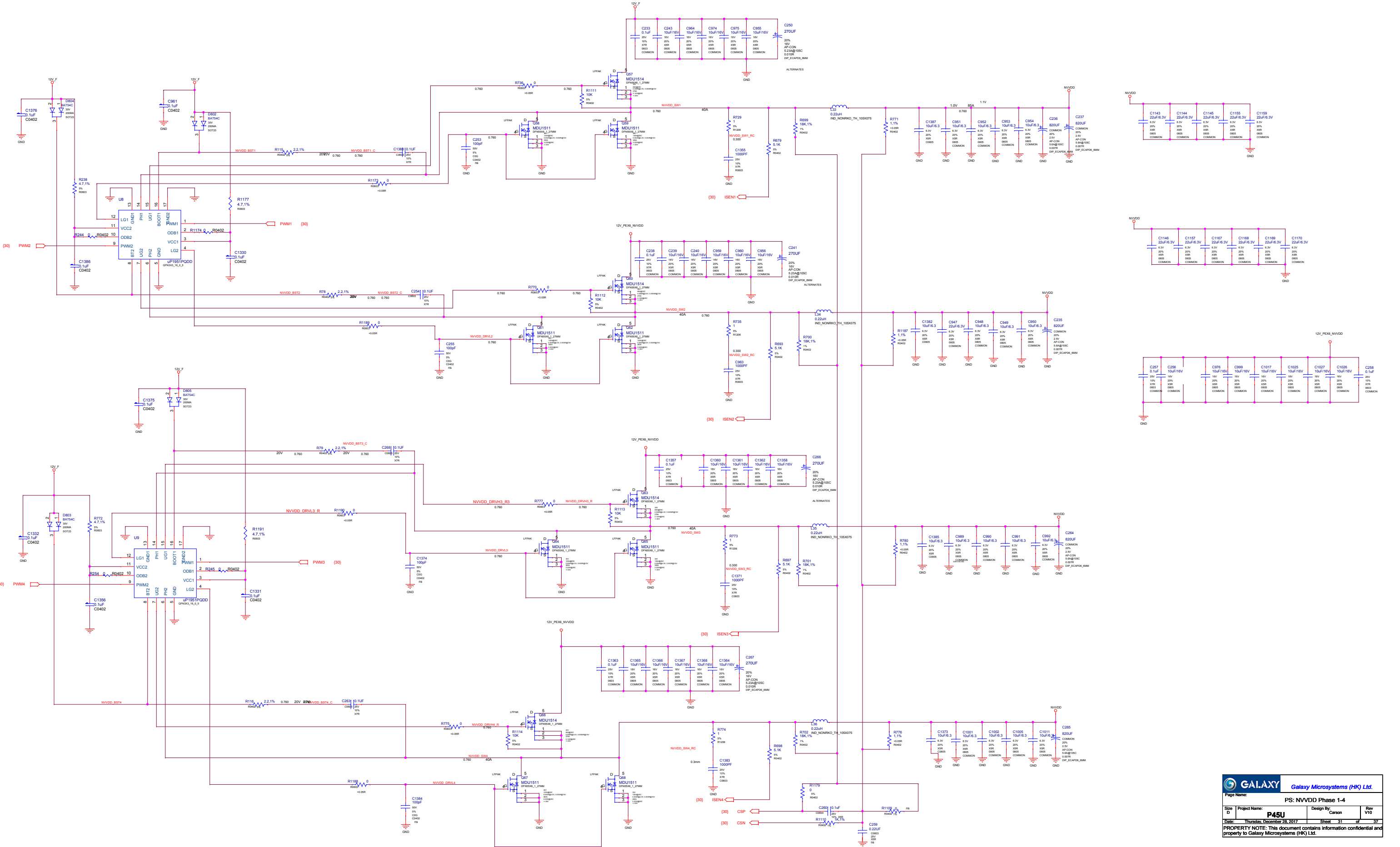

**GALAXY** Galaxy Microsystems (HK) Ltd.

Page Name: PS: NVDD Phase 1-4

Size D	Project Name: P45U	Design By: Carson	Rev: V10
Date: Thursday, December 28, 2017	Sheet: 31 of 37	PROPERTY NOTE: This document contains information confidential and property to Galaxy Microsystems (HK) Ltd.	

A B C D E F G H

1

1

2

2

3

3

4

4

5

5

		Galaxy Microsystems (HK) Ltd.	
Page Name: Blank page			
Size: Custom	Project Name: <b>P45U</b>	Design By: Carson	Rev: V10
Date: Thursday, December 28, 2017	Sheet 32	of	37
PROPERTY NOTE: This document contains information confidential and property to Galaxy Microsystems (HK) Ltd.			

ASSEMBLY PAGE DETAIL	-ASSEMBLY_DESCRIPTION- PS: NVVDD Rail Balance Login & Dynamic Phase
-------------------------	--

ALL NVIDIA DESIGN SPECIFICATIONS, REFERENCE SPECIFICATIONS, REFERENCE BOARDS, FILES, DRAWINGS, DIAGNOSTICS, LISTS AND OTHER DOCUMENTS OR INFORMATION (TOGETHER AND SEPARATELY, 'MATERIALS') ARE BEING PROVIDED 'AS IS'. THE MATERIALS MAY CONTAIN KNOWN AND UNKNOWN VIOLATIONS OR DEVIATIONS OF INDUSTRY STANDARDS AND SPECIFICATIONS. NVIDIA MAKES NO WARRANTIES, EXPRESSED, IMPLIED, STATUTORY OR OTHERWISE WITH RESPECT TO THE MATERIALS OR OTHERWISE, AND EXPRESSLY DISCLAIMS ALL IMPLIED WARRANTIES INCLUDING, WITHOUT LIMITATION, THE WARRANTIES OF DESIGN, OF NONINFRINGEMENT, MERCHANTABILITY OR FITNESS FOR A PARTICULAR PURPOSE, OR ARISING FROM A COURSE OF DEALING, TRADE USAGE, TRADE PRACTICE, OR INDUSTRY STANDARDS.

A B C D E F G H



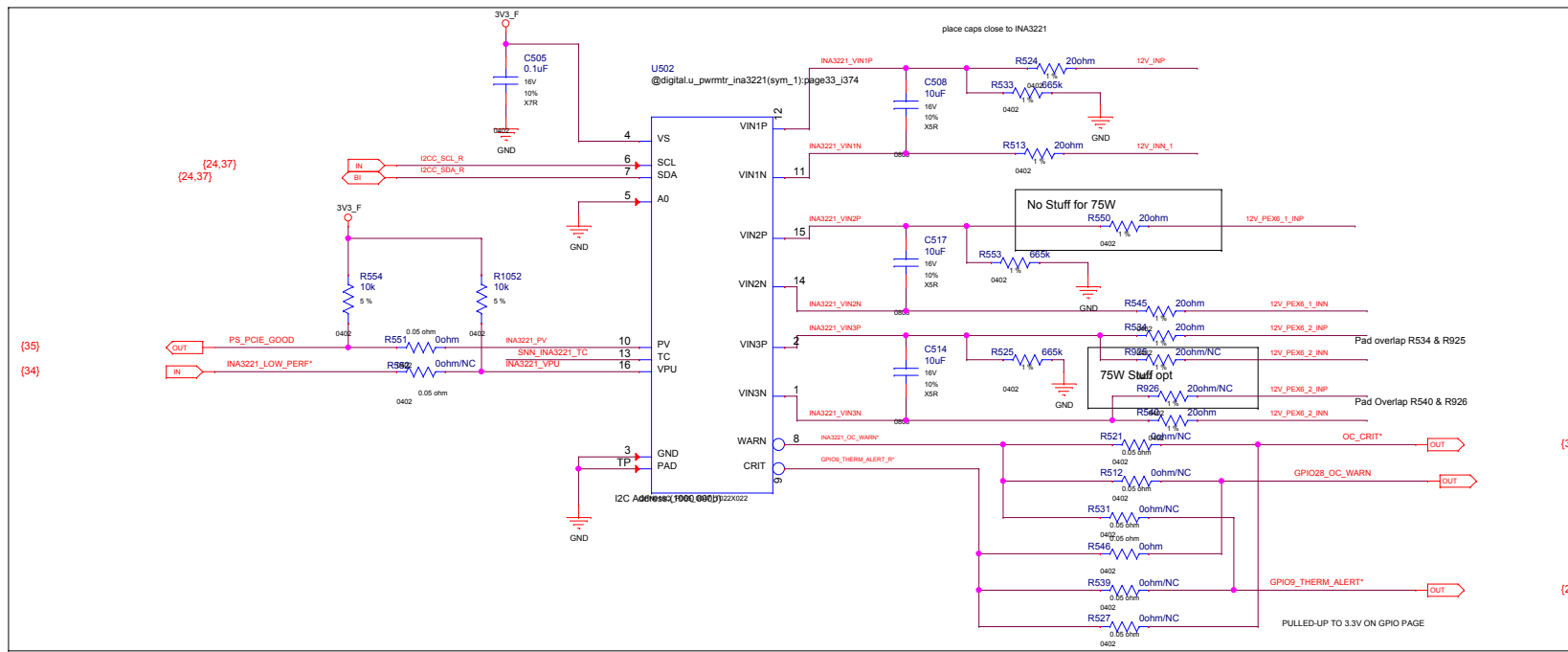

PEX 3V3 INPUT - 10W

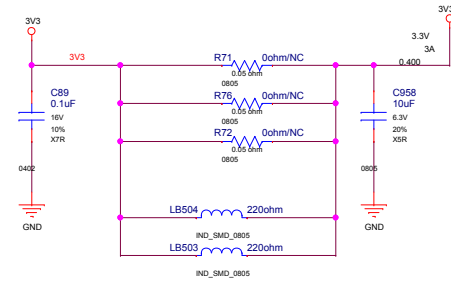

PEX6 INPUT 1 - 2x3 PCIE CON 75W

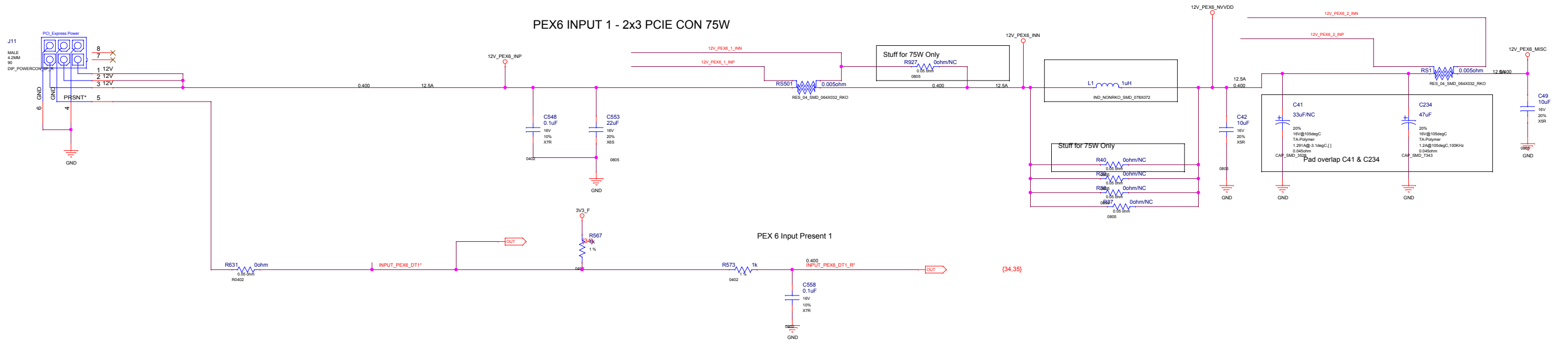

PEX\_12V INPUT - 66W

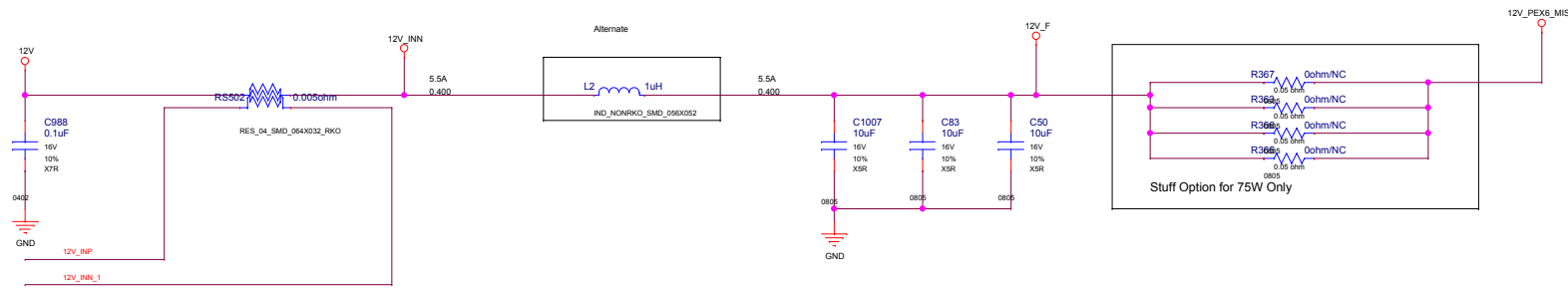

Place close to J14/J16  
 J14 and J16 is the soldering holes for power cable.  
 The power cable Need a separate wire as detect pin  
 This detect wire need be soldered on J15

ASSEMBLY PAGE DETAIL	ASSEMBLY DESCRIPTION PS: Input, Filtering, and Monitoring
----------------------	--

**GALAXY** Galaxy Microsystems (HK) Ltd.

Page Name: PS: Input, Filtering, and Monitoring

Size: Custom	Project Name: P45U	Design By: Carson	Rev: V10
Date: Thursday, December 28, 2017	Sheet: 33	of 37	

PROPERTY NOTE: This document contains information confidential and property to Galaxy Microsystems (HK) Ltd.

ALL NVIDIA DESIGN SPECIFICATIONS, REFERENCE SPECIFICATIONS, REFERENCE BOARDS, FILES, DRAWINGS, DIAGNOSTICS, LISTS AND OTHER DOCUMENTS OR INFORMATION (TOGETHER AND SEPARATELY, "MATERIALS") ARE BEING PROVIDED "AS IS". THE MATERIALS MAY CONTAIN KNOWN AND UNKNOWN VIOLATIONS OR DEVIATIONS OF INDUSTRY STANDARDS AND SPECIFICATIONS. NVIDIA MAKES NO WARRANTIES, EXPRESSED, IMPLIED, STATUTORY OR OTHERWISE WITH RESPECT TO THE MATERIALS OR OTHERWISE, AND EXPRESSLY DISCLAIMS ALL IMPLIED WARRANTIES INCLUDING, WITHOUT LIMITATION, THE WARRANTIES OF DESIGN, OF NON-INFRINGEMENT, MERCHANTABILITY OR FITNESS FOR A PARTICULAR PURPOSE, OR ARISING FROM A COURSE OF DEALING, TRADE USAGE, TRADE PRACTICE, OR INDUSTRY STANDARDS.

12V CURRENT STEERING (UNDER POWER BOOT):

GUIDES CURRENT FROM PEX EDGE TO PEX 6 PIN INPUT AREA

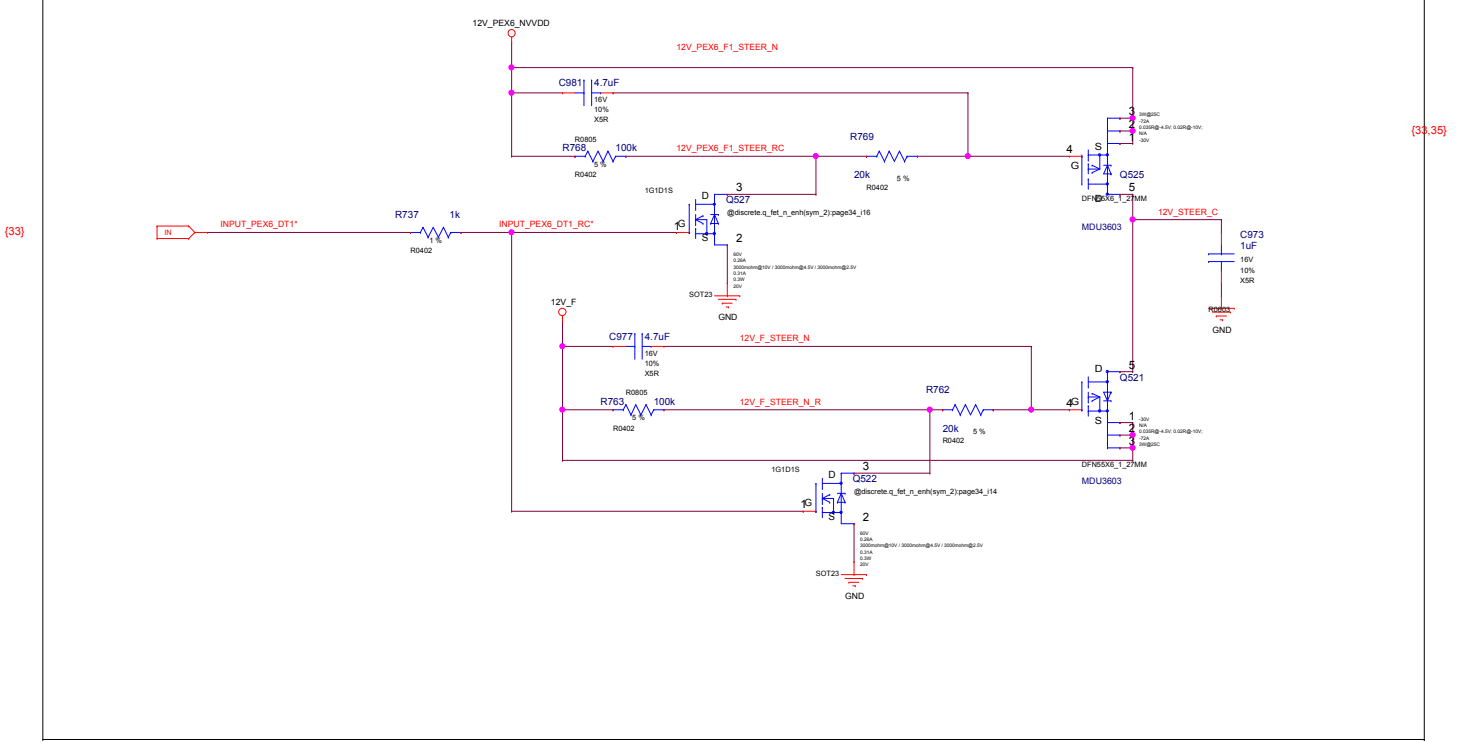

PEX Input - Power Level/PSI\* Control

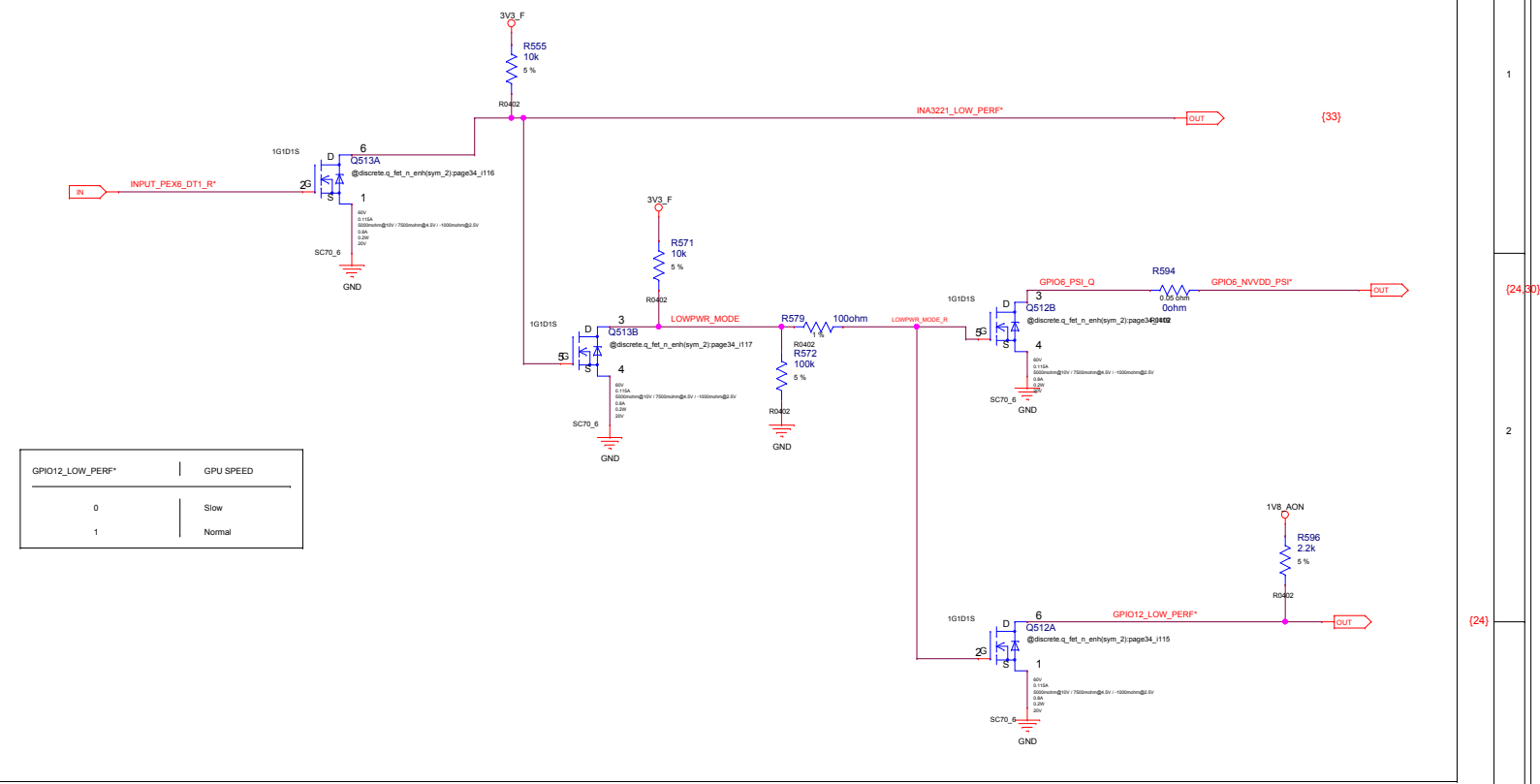

GPIO12_LOW_PERF*	GPU SPEED
0	Slow
1	Normal

GeForce Logo LED

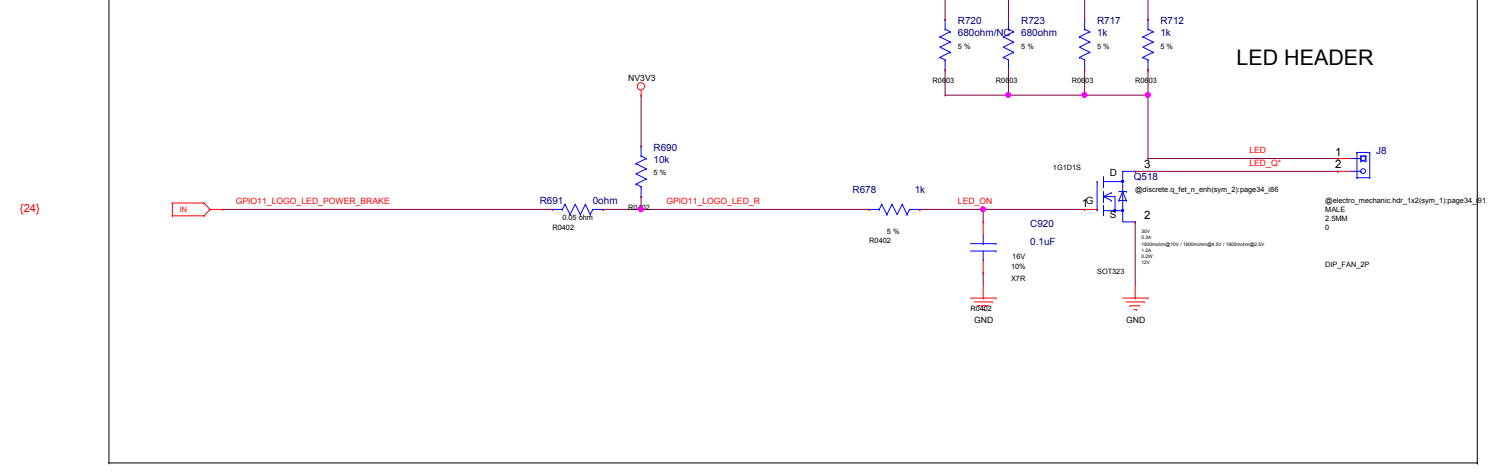

ALL NVIDIA DESIGN SPECIFICATIONS, REFERENCE SPECIFICATIONS, REFERENCE BOARDS, FILES, DRAWINGS, DIAGNOSTICS, LISTS AND OTHER DOCUMENTS OR INFORMATION (TOGETHER AND SEPARATELY, "MATERIALS") ARE BEING PROVIDED "AS IS". THE MATERIALS MAY CONTAIN KNOWN AND UNKNOWN VIOLATIONS OR DEVIATIONS OF INDUSTRY STANDARDS AND SPECIFICATIONS. NVIDIA MAKES NO WARRANTIES, EXPRESSED, IMPLIED, STATUTORY OR OTHERWISE WITH RESPECT TO THE MATERIALS OR OTHERWISE, AND EXPRESSLY DISCLAIMS ALL IMPLIED WARRANTIES INCLUDING, WITHOUT LIMITATION, THE WARRANTIES OF DESIGN, OF NONINFRINGEMENT, MERCHANTABILITY OR FITNESS FOR A PARTICULAR PURPOSE, OR ARISING FROM A COURSE OF DEALING, TRADE USAGE, TRADE PRACTICE, OR INDUSTRY STANDARDS.

ASSEMBLY PAGE DETAIL	ASSEMBLY DESCRIPTION
	PS: 12V Power Steering, PSI Control & LED

**GALAXY** Galaxy Microsystems (HK) Ltd.

Page Name: PS: 12V Power Steering, PSI Control & LED

Size: Custom	Project Name: P45U	Design By: Carson	Rev: V10
Date: Thursday, December 28, 2017	Sheet: 34	of: 37	

PROPERTY NOTE: This document contains information confidential and property to Galaxy Microsystems (HK) Ltd.

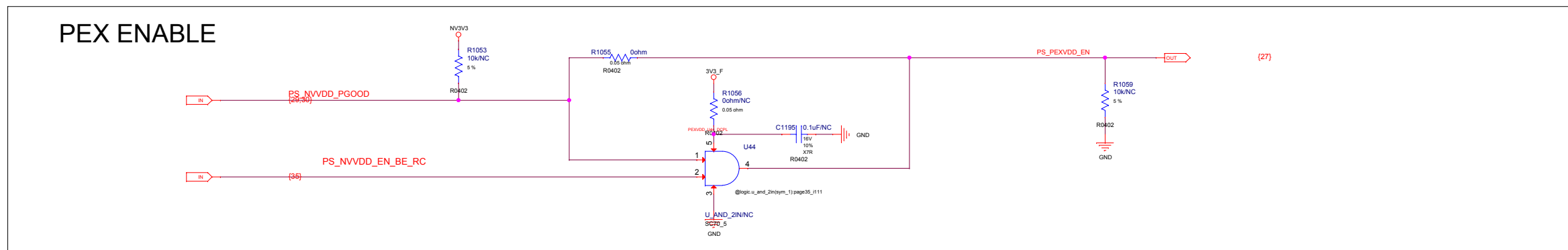
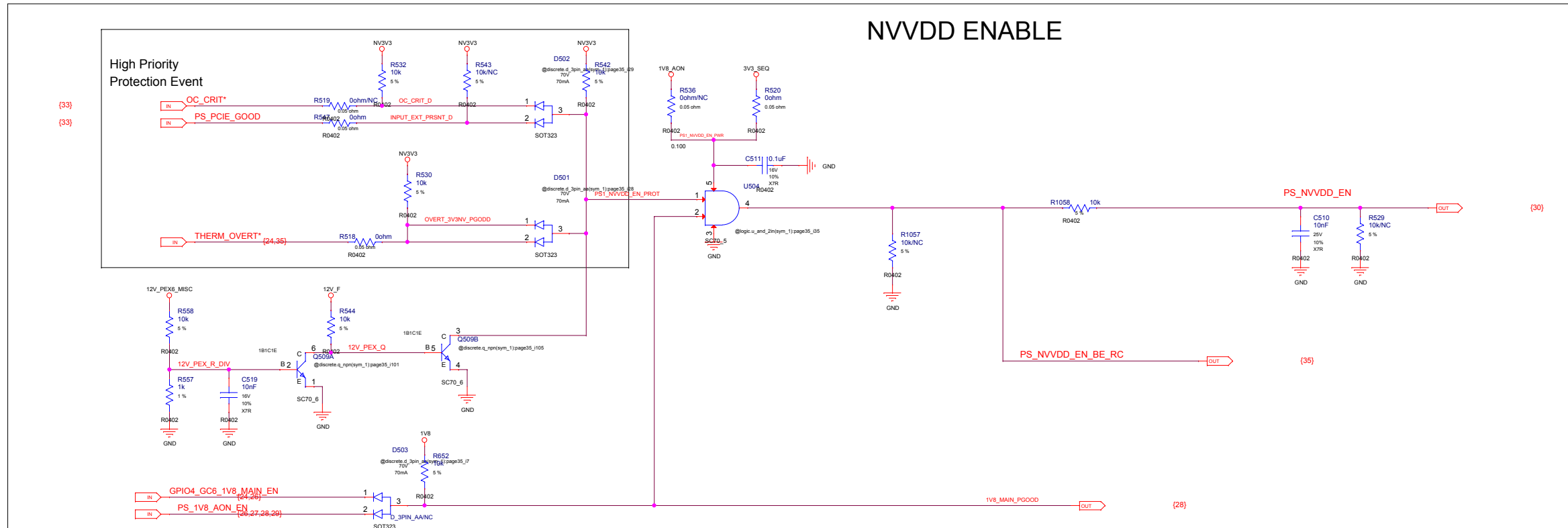
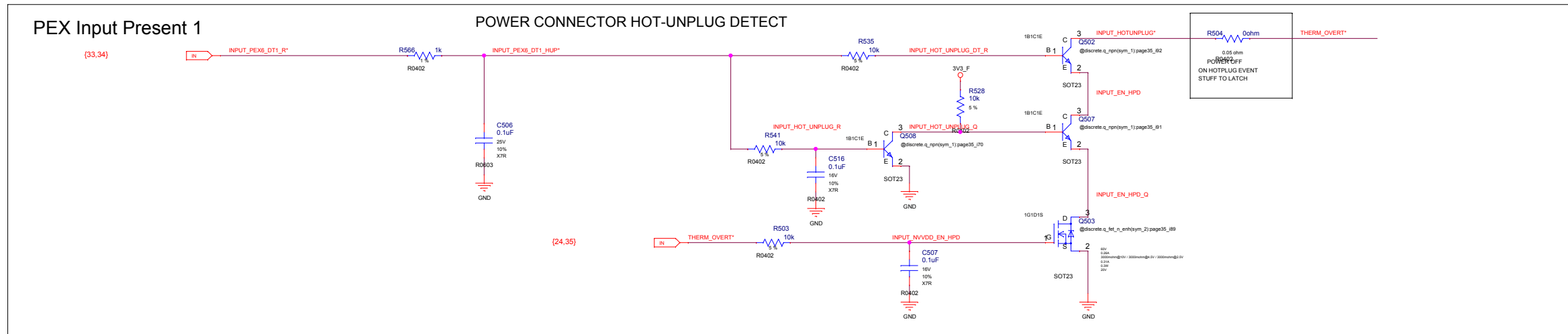

ALL NVIDIA DESIGN SPECIFICATIONS, REFERENCE SPECIFICATIONS, REFERENCE BOARDS, FILES, DRAWINGS, DIAGNOSTICS, LISTS AND OTHER DOCUMENTS OR INFORMATION (TOGETHER AND SEPARATELY, "MATERIALS") ARE BEING PROVIDED "AS IS". THE MATERIALS MAY CONTAIN KNOWN AND UNKNOWN VIOLATIONS OR DEVIATIONS OF INDUSTRY STANDARDS AND SPECIFICATIONS. NVIDIA MAKES NO WARRANTIES, EXPRESSED, IMPLIED, STATUTORY OR OTHERWISE WITH RESPECT TO THE MATERIALS OR OTHERWISE, AND EXPRESSLY DISCLAIMS ALL IMPLIED WARRANTIES INCLUDING, WITHOUT LIMITATION, THE WARRANTIES OF DESIGN, OF NONINFRINGEMENT, MERCHANTABILITY OR FITNESS FOR A PARTICULAR PURPOSE, OR ARISING FROM A COURSE OF DEALING, TRADE USAGE, TRADE PRACTICE, OR INDUSTRY STANDARDS.

ASSEMBLY PAGE DETAIL	<ASSEMBLY_DESCRIPTION> PS: Shut Down and Sequencing
----------------------	--

**GALAXY** Galaxy Microsystems (HK) Ltd.

Page Name: PS: Shut Down and Sequencing

Size: Custom	Project Name: P45U	Design By: Carson	Rev: V10
Date: Thursday, December 28, 2017	Sheet: 35	of: 37	

PROPERTY NOTE: This document contains information confidential and property to Galaxy Microsystems (HK) Ltd.

PEX\_CLKREQ\*

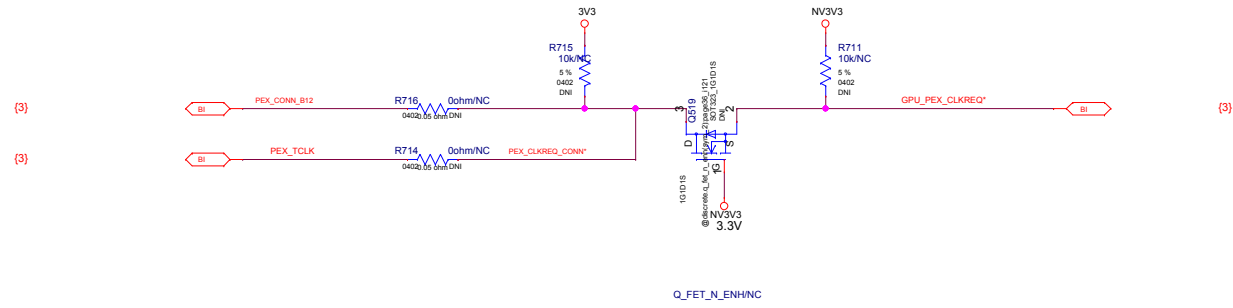

GPU\_EVENT\*

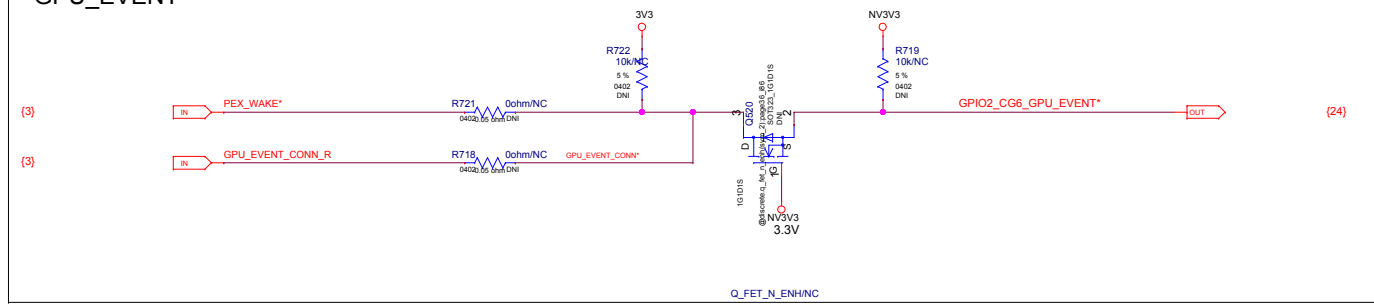

PEX\_RST# LOGIC

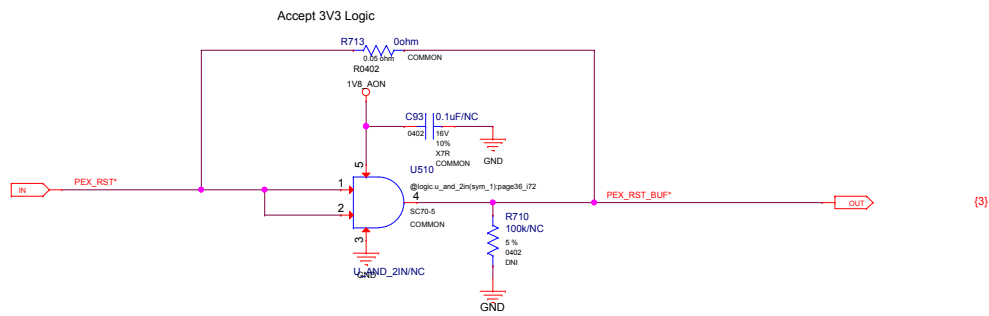

GC6 FB ENABLE

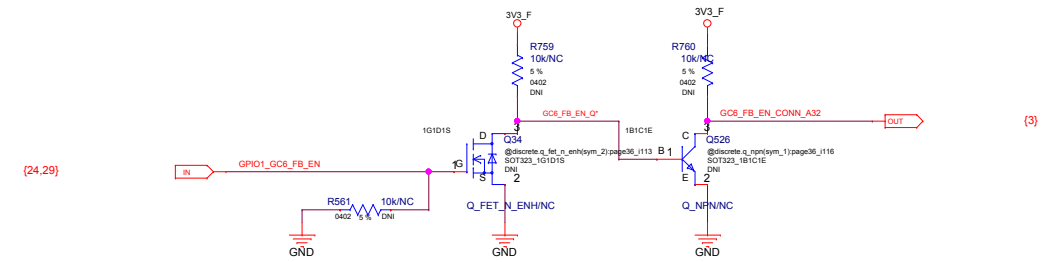

ALL NVIDIA DESIGN SPECIFICATIONS, REFERENCE SPECIFICATIONS, REFERENCE BOARDS, FILES, DRAWINGS, DIAGNOSTICS, LISTS AND OTHER DOCUMENTS OR INFORMATION (TOGETHER AND SEPARATELY, 'MATERIALS') ARE BEING PROVIDED 'AS IS'. THE MATERIALS MAY CONTAIN KNOWN AND UNKNOWN VIOLATIONS OR DEVIATIONS OF INDUSTRY STANDARDS AND SPECIFICATIONS. NVIDIA MAKES NO WARRANTIES, EXPRESSED, IMPLIED, STATUTORY OR OTHERWISE WITH RESPECT TO THE MATERIALS OR OTHERWISE, AND EXPRESSLY DISCLAIMS ALL IMPLIED WARRANTIES INCLUDING, WITHOUT LIMITATION, THE WARRANTIES OF DESIGN, OF NONINFRINGEMENT, OR ARISING FROM A COURSE OF DEALING, TRADE USAGE, TRADE PRACTICE, OR INDUSTRY STANDARDS.

ASSEMBLY PAGE DETAIL	-ASSEMBLY_DESCRIPTION- PS: GC6 MISC
----------------------	-------------------------------------

Page Name: PS: GC6 MISC			
Size: Custom	Project Name: P45U	Design By: Carson	Rev: V10
Date: Thursday, December 28, 2017	Sheet: 36	of	37
PROPERTY NOTE: This document contains information confidential and property to Galaxy Microsystems (HK) Ltd.			

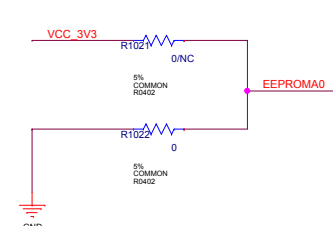
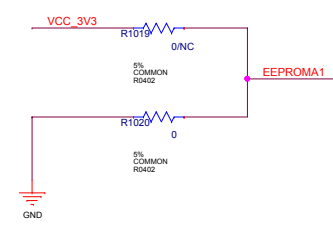
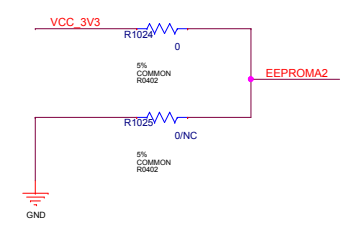
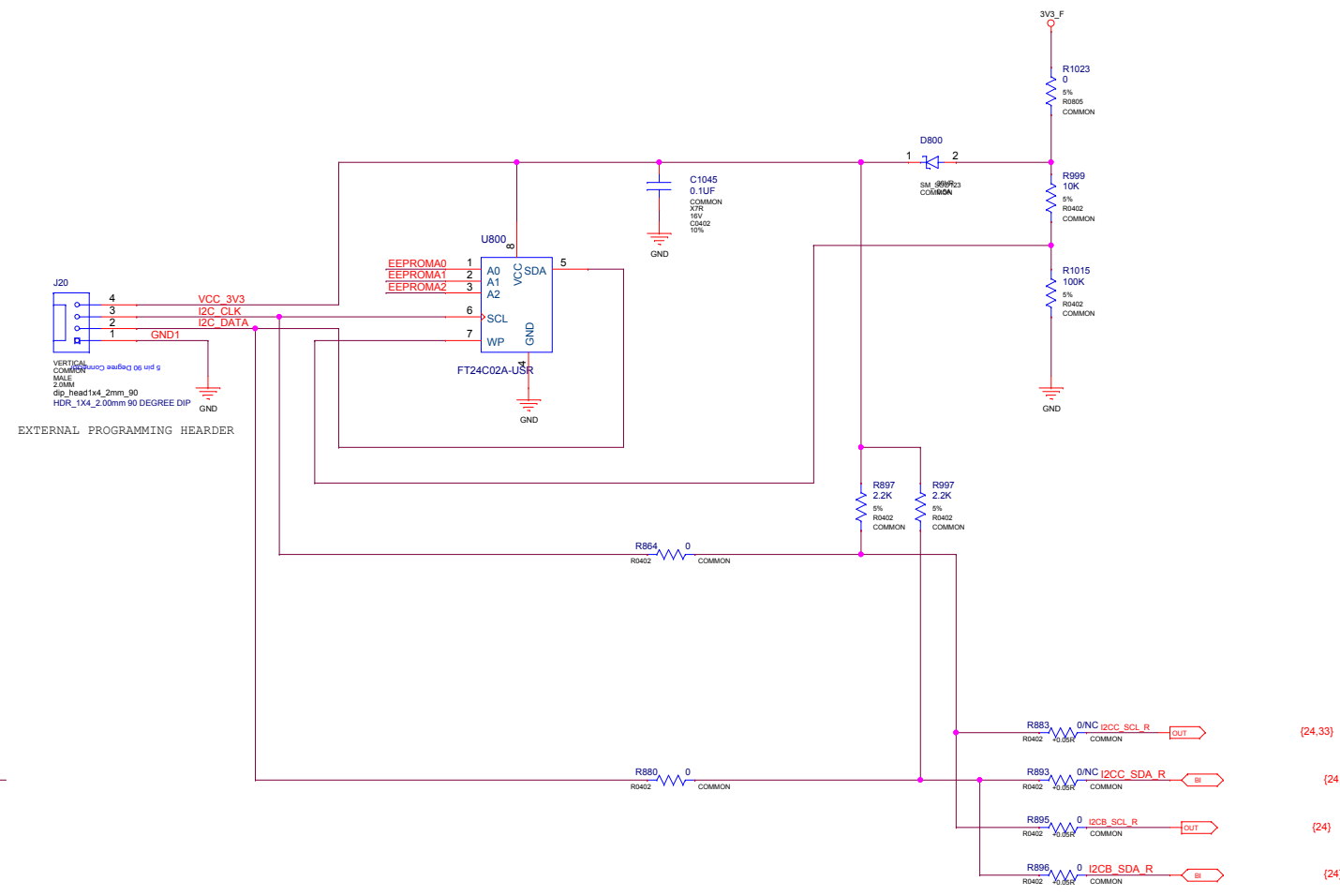

MOUNTING HOLES FOR HS DS:

GPU Stiffener:

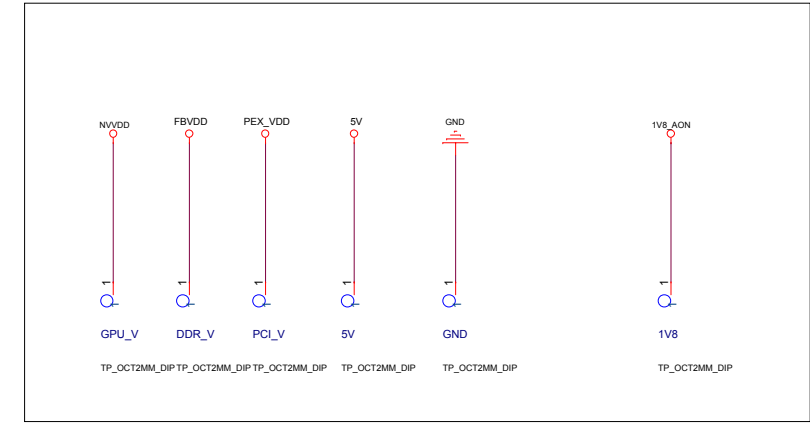
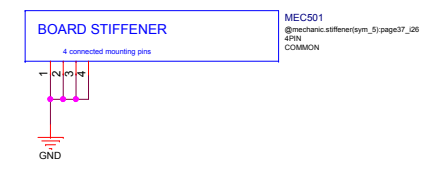

MOUNTING HOLES FOR HS SS:

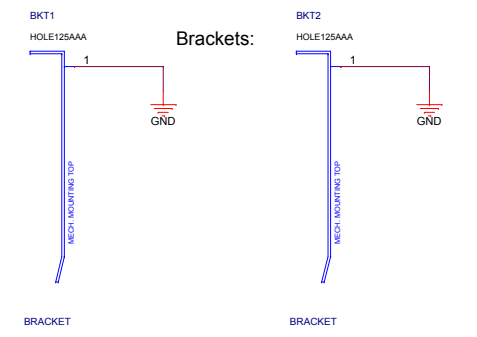

Brackets:

ALL NVIDIA DESIGN SPECIFICATIONS, REFERENCE SPECIFICATIONS, REFERENCE BOARDS, FILES, DRAWINGS, DIAGNOSTICS, LISTS AND OTHER DOCUMENTS OR INFORMATION (TOGETHER AND SEPARATELY, 'MATERIALS') ARE BEING PROVIDED 'AS IS'. THE MATERIALS MAY CONTAIN KNOWN AND UNKNOWN VIOLATIONS OR DEVIATIONS OF INDUSTRY STANDARDS AND SPECIFICATIONS. NVIDIA MAKES NO WARRANTIES, EXPRESSED, IMPLIED, STATUTORY OR OTHERWISE WITH RESPECT TO THE MATERIALS OR OTHERWISE, AND EXPRESSLY DISCLAIMS ALL IMPLIED WARRANTIES INCLUDING, WITHOUT LIMITATION, THE WARRANTIES OF DESIGN, OF NONINFRINGEMENT, MERCHANTABILITY OR FITNESS FOR A PARTICULAR PURPOSE, OR ARISING FROM A COURSE OF DEALING, TRADE USAGE, TRADE PRACTICE, OR INDUSTRY STANDARDS.

ASSEMBLY PAGE DETAIL	<ASSEMBLY_DESCRIPTION> MECH
----------------------	-----------------------------

**GALAXY** Galaxy Microsystems (HK) Ltd.

Page Name: MECH\_SN EEPRON

Size: Custom	Project Name: P45U	Design By: Carson	Rev: V10
Date: Thursday, December 28, 2017	Sheet: 37	of: 37	

PROPERTY NOTE: This document contains information confidential and property to Galaxy Microsystems (HK) Ltd.